

SECTION - 1
INVITATION FOR BIDS (IFB)

INVITATION FOR BIDS (IFB) FOR

Name of the Tender/Package: “Refurbishment and Repair & Maintenance of CCMS along with comprehensive on-site warranty (including supply of spares parts) for a period until the project completion of respective ULB in Street lighting project in the state of Telangana.”

Sr. No.	Details	
1.	Date of issuance of IFB	25.09.2024
2.	NIT/Bid Document No.:	EESL/06/24-25/SERC-Contracts/TS/CCMS -GHMC & ULB/OTE-232414, Date: 25/09/2024
3.	Funding	Domestic
4.	Name of the Employer/ Buyer/ Owner	Energy Efficiency Services Limited
5.	Publication	This invitation for bids follows the <u>e-procurement notice</u> (Invitation for Bids) for the subject package published on EESL Website and e-procurement portal (www.tenderwizard.com/EESL) and on Government of India’s Central Public Procurement Portal (https://eprocure.gov.in). Any Corrigendum and/or amendments, etc. shall also be published only on the above website/portals.
6.	e-procurement portal	EESL’s e-portal is www.tenderwizard.com/EESL (e-portal) Government of India’s Central Public Procurement Portal is https://eprocure.gov.in (Refer <i>Annexure-I</i> to this Section for Important Instruction for participation in the e-Bidding through e-portal).
7.	Bidding Procedure	Single Stage Two Envelope Bidding (Domestic Competitive Bidding under e-procurement)
8.	Brief Scope of Work	Refurbishment and Repair & Maintenance of CCMS along with comprehensive on-site warranty (including supply of spares parts) for a period until the project completion of respective ULB in Street lighting project in the state of Telangana. (The detailed scope of work is given in the Technical Specification (Part-C of Section-4) of the RfP Documents).

Sr. No.	Details						
9.	<p data-bbox="318 264 545 296">Completion Period</p> <table border="1" data-bbox="626 296 1398 663"> <thead> <tr> <th data-bbox="634 306 737 327">Sl. No.</th> <th data-bbox="737 306 967 327">Activity</th> <th data-bbox="967 306 1390 327">Completion Period</th> </tr> </thead> <tbody> <tr> <td data-bbox="634 327 737 653">1.</td> <td data-bbox="737 327 967 653">Refurbishment and Repair & Maintenance of CCMS along with comprehensive on-site warranty (including supply of spares parts)</td> <td data-bbox="967 327 1390 653">The refurbishment work has to be completed within One (1) month from the date of issuance of LoA. The Repair and Maintenance along with comprehensive on-site warranty of CCMS will start from the completion of refurbishment period (i.e., 1 month) and continue until the project completion of the respective ULB.</td> </tr> </tbody> </table>	Sl. No.	Activity	Completion Period	1.	Refurbishment and Repair & Maintenance of CCMS along with comprehensive on-site warranty (including supply of spares parts)	The refurbishment work has to be completed within One (1) month from the date of issuance of LoA. The Repair and Maintenance along with comprehensive on-site warranty of CCMS will start from the completion of refurbishment period (i.e., 1 month) and continue until the project completion of the respective ULB.
Sl. No.	Activity	Completion Period					
1.	Refurbishment and Repair & Maintenance of CCMS along with comprehensive on-site warranty (including supply of spares parts)	The refurbishment work has to be completed within One (1) month from the date of issuance of LoA. The Repair and Maintenance along with comprehensive on-site warranty of CCMS will start from the completion of refurbishment period (i.e., 1 month) and continue until the project completion of the respective ULB.					
10.	<p data-bbox="318 705 545 768">Qualifying Requirements (QR)</p> <p data-bbox="643 705 1341 768">The detailed Qualifying Requirements (QR) are given at Part-B of Section-4 of the RfP Documents.</p>						
11.	<p data-bbox="318 810 480 873">RfP/ Bidding Documents</p> <p data-bbox="643 810 1414 873">The complete RfP/ Bidding Documents are available at EESL's e-procurement portal www.tenderwizard.com/EESL.</p> <p data-bbox="643 905 1414 1041">The bidding documents are meant for the exclusive purpose of bidding against this specification and shall not be transferred to any parts or reproduced or used otherwise for any purpose other than for which they are specifically uploaded.</p>						
12.	<p data-bbox="318 1073 513 1094">Pre-bid meeting</p> <p data-bbox="643 1073 1081 1167">The Pre-bid meeting is scheduled on Date:08/10/2024 Time: 11:00 Hrs IST Place: Video Conference/ Online</p> <p data-bbox="643 1199 1219 1230">Virtual Meeting at link provided below this table.</p>						
13.	<p data-bbox="318 1304 610 1367">Deadline for submission of bids</p> <p data-bbox="643 1304 1300 1335">Soft Copy Part of the Bids: 24/10/2024 till 11:00 Hrs. IST</p> <p data-bbox="643 1367 1317 1398">Hard Copy Part of the Bids: 24/10/2024 till 11:00 Hrs. IST</p>						
14.	<p data-bbox="318 1440 480 1461">Bid Opening:</p> <p data-bbox="643 1440 1414 1503">Envelope-1 (First Envelope) (Comprising Packet-I and Packet-II): Date: 24/10/2024 Time: 11:30 Hrs. IST</p> <p data-bbox="643 1535 1414 1629">Envelope-2 (Second Envelope) (Comprising Price Bid):Schedule shall be intimated after evaluation of First Envelope bids in accordance with ITB, Section-2.</p> <p data-bbox="626 1671 1422 1755"><i>(Bids shall be opened in the presence of the bidders' representatives who choose to attend in person at the address below or may be viewed by the bidders by logging in to the portal).</i></p>						

Sr. No.	Details													
15.	Bidding Document/Tender fee	Rs. 25,000.00 (Rupees Twenty Five Thousand Only) Document/Tender Fee must be submitted either in physical form or paid online (for details refer ITB 1.4, Section-2).												
16.	Bid Security/EMD	<p>Bid Security/EMD cluster wise detail is mentioned below:</p> <table border="1"> <thead> <tr> <th>Sl. No.</th> <th>Name of the Package</th> <th>Amount (in Rs.)</th> </tr> </thead> <tbody> <tr> <td>1.</td> <td>Package - 1</td> <td>13,73,000.00</td> </tr> <tr> <td>2.</td> <td>Package - 2</td> <td>16,65,000.00</td> </tr> <tr> <td></td> <td>Total (in Rs.)</td> <td>30,38,000.00</td> </tr> </tbody> </table> <p>Bidder has to submit EMD as per above table for respective Cluster in which they are bidding.</p> <p>Bid security / EMD must be submitted either in physical form or paid online (for details refer ITB 2.4, Section-2).</p>	Sl. No.	Name of the Package	Amount (in Rs.)	1.	Package - 1	13,73,000.00	2.	Package - 2	16,65,000.00		Total (in Rs.)	30,38,000.00
Sl. No.	Name of the Package	Amount (in Rs.)												
1.	Package - 1	13,73,000.00												
2.	Package - 2	16,65,000.00												
	Total (in Rs.)	30,38,000.00												
17.	Address for correspondence	<p>(By Post/In Person) Addl. General Manager (Contracts)/Engineer (Contracts) Energy Efficiency Services Limited, Buddha Bhawan, 3rd Floor, North block, MG Road Ranigunj, Secunderabad-500003, Telangana Email: Primary - asrao@eesl.co.in, Secondary - u_esrinivas@eesl.co.in</p>												

https://teams.microsoft.com/l/meetup-join/19%3ameeting_MTVmNmMzODUtNmQwZC00Zjk2LWEzMjYtZmQzNDg4ZDVhZmUw%40thread.v2/0?context=%7b%22Tid%22%3a%224a993be3-3ce0-49c4-96e9-23324992b1dd%22%2c%22Oid%22%3a%226d30b4d5-6b30-4d76-b8dd-f872bd9da8fc%22%7d

Note:

1. Bidding will be conducted through the domestic competitive bidding procedures as per the provisions of ITB, Section-2 and the contract shall be executed as per the provisions of the Contract.
2. In case Hard copy part of the bid is not received by the Employer till the deadline for submission of the same prescribed by the Employer, but the bidder has uploaded the soft copy part of the bid, the soft copy part of the Envelope-1 (First Envelope) bid uploaded on the portal shall be opened in line with provisions of Bidding Documents. Such bids will be rejected during preliminary examination. However, in case of MSEs who are exempted from submission of Bidding Document/Tender fee and Bid Security/EMD in line with Annexure-II, non-submission of Hard copy part shall not lead to outright rejection of the bid, but the documents required to be submitted in the hard copy part shall be sought through clarifications as brought out at ITB 4.2, Section-2.
3. EESL reserves the right to cancel/withdraw this invitation for bids without assigning any reason and shall bear no liability whatsoever consequent upon such a decision.

---- End of Section-I (IFB) ----

NIT/Bid Document No.: EESL/06/24-25/SERC-Contracts/TS/CCMS - GHMC & ULB/OTE-232414, Date: 25/09/2024	SECTION -1 (IFB)	Page 4 of 4
--	------------------	-------------

SECTION-2

INSTRUCTIONS TO THE BIDDERS (ITB)

SECTION-2

1. Instructions to the bidder (ITB)

1.1 The bidding documents include the following

Section-1	Invitation for Bids (IFB) including Annexure-I (provisions regarding registration on e-portal)
Section-2	Instructions to Bidder / Consortium of Bidders
Section-3	General Conditions of Contract
Section-4 (Part-A)	Bid Data Sheet (BDS) including Annexure-II (Provisions for MSE Bidders and Start-ups)
Section-4 (Part-B)	Qualification Requirement
Section-4 (Part-C)	Technical Specification interalia, Scope of Work, BoQ and other Parameters
Section-4 (Part-D)	Special Conditions of Contract
Section-5	Measurements and Verification
Section-6	Forms & Procedure

The bidder is expected to examine all the instructions, forms, terms, specifications and other information in the bidding documents. Failure to furnish all information required by the bidding documents or submission of a bid not substantially responsive to the bidding documents in every respect will be at the bidder's risk and may result in rejection of bid.1

1.1.1 Source of funds:

The Employer named in the **BDS** intends to use domestic funding for this Project. All eligible payments under the contract for the Tender for which this Invitation for Bids is issued shall be made by the Employer named in the **BDS**.

1.1.2 Eligible Bidders:

- (i) This Invitation for Bids, issued by the Employer is Open to all firms including company(ies), those Government owned Enterprises registered and incorporated in India as per Companies Act, 1956, barring Government Department as well as foreign bidders/MNCs not registered and incorporated in India and those bidders with whom business is banned by the Employer.
- (ii) A Bidder shall not have a conflict of interest. All Bidders found to have a conflict of interest shall be disqualified. A Bidder may be considered to have a conflict of interest with one or more parties in this bidding process, if:
 - (a) they have a controlling partner in common; or
 - (b) they receive or have received any direct or indirect subsidy from any of them; or
 - (c) they have the same legal representative for purposes of this bid; or

- (d) they have a relationship with each other, directly or through common third parties, that puts them in a position to have access to information about or influence on the bid of another Bidder, or influence the decisions of the Employer regarding this bidding process; or
 - (e) a Bidder submits more than one bid in this bidding process, either individually [including bid submitted as an agent/authorized representative on behalf of one or more manufacturer(s) or through Licensee - Licensor route, wherever permitted as per the provision of Qualification Requirement for the Bidders in Part - B, Section-4] or as a partner in a joint venture, except for alternative offers permitted under the RfP Documents. This will result in the disqualification of all such bids. However, this does not limit the participation of a Bidder as a subcontractor in another bid, or of a firm as a subcontractor in more than one bid; or
 - (f) a Bidder or any of its affiliates participated as a consultant in the preparation of the design or technical specifications of the Plant and Installation Services and Facilities that are the subject of the bid; or
 - (g) a Bidder (including its personnel or sub-contractors) has a business or family relationship with a member of a EESL's staff (or of the project implementing staff, or of a recipient of a part of the loan) who: are directly or indirectly involved in the preparation of the bidding documents or specifications of the contract, and/or the bid evaluation process of such contract; or would be involved in the implementation or supervision of such contract unless the authority inviting tenders shall be informed of the fact/ such relationship at the time of submission of the tender and the conflict stemming from such relationship has been resolved in a manner acceptable to the EESL throughout the procurement process and execution of the contract. EESL may in its discretion reject the tender or rescind the contract.; or
 - (h) A Bidder or any of its affiliates has been hired (or is proposed to be hired) by the Employer as Project Manager for the contract.
- (iii) The Bidder, directly or indirectly shall not be a dependent agency of the Employer.
- (iv) In case a prequalification process has been conducted prior to the bidding process, this bidding is open only to prequalified Bidders.

Interpretations

1. Words comprising the singular shall include the plural & vice versa
2. An applicable law shall be construed as reference to such applicable law including its amendments or re-enactments from time to time.
3. A time of day shall save as otherwise provided in any agreement or document be construed as a reference to Indian Standard Time.
4. Different parts of this contract are to be taken as mutually explanatory and supplementary to each other and if there is any differentiation between or among the parts of this contract, they shall be interpreted in a harmonious manner so as to give effect to each part.
5. The table of contents and any headings or sub headings in the contract has been inserted for case of reference only & shall not affect the interpretation of this agreement.

1.2 Clarification on Bidding Documents

A prospective Bidder requiring any clarification to the bidding documents may notify the EESL in writing or by post or by telex or telefax or email) at the EESL's mailing address indicated in the BDS. The EESL will respond in writing to any request for clarification or modification of the bidding documents that it receives no later than Five (05) days prior to the deadline for submission of bids prescribed by the EESL. Written copies of the EESL's response (including an explanation of the query but not identification of its source) will be sent to all prospective Bidders.

The Bidder is advised to visit and examine the site where the Facilities are to be installed and its surroundings and obtain for itself on its own responsibility all information that may be necessary for preparing the bid and entering into a contract for supply and installation of the Facilities. The costs of visiting the site shall be borne by the bidder fully.

EESL will also facilitate the bidder and any of its personnel or agents for getting permission from the authorities, where actual work is to be executed, to enter upon its premises and lands for the purpose of such inspection, but only upon the express condition that the Bidder, its personnel and agents will release and indemnify the EESL and also the authorities, where work is to be executed, and its personnel and agents from and against all liability in respect thereof and will be responsible for death or personal injury, loss of or damage to property and any other loss, damage, costs and expenses incurred as a result of the inspection.

Whenever the bidder is silent about the acceptance of RfP/IFB conditions such as bank guarantee, warranty period, liquidated damages, certification of relation clause no.1.1.2 [Conflict of Interest] etc. it shall be presumed that the bidder has accepted and certified RfP/IFB conditions and no further correspondence seeking specific confirmation about acceptance of these conditions shall be made.

The Bidder shall be deemed to have examined the Bidding document, to have obtained his own information in all matters whatsoever that might affect carrying out the Works in line with the Technical specifications and Scope of Work specified in the document at the offered rates and to have satisfied himself to the sufficiency of his Bid. The bidder shall be deemed to know the scope, nature and magnitude of the work and requirement of materials, equipment, tools and labour involved, local and national wage structures and as to what all works he has to complete in accordance with the Bid documents irrespective of any defects, omissions or errors that may be found in the Bidding documents.

1.3 Amendment to bidding documents

At any time prior to the deadline for submission of bids, the EESL may, for any reason, whether at its own initiative, or in response to a clarification requested by a prospective Bidder, amend the bidding documents.

The amendment will be notified only through the e-procurement portal. Further, the notification of amendment shall also be sent by the portal directly to all the prospective bidders who have performed the requisite activity on the e-Portal for the subject tender as per the provisions of the Portal. The amendments to the Bidding Documents will be binding on the bidders and the notification of the amendment through portal, sent to the prospective bidders, shall be deemed to be construed that such amendment(s) to the Bidding Documents have been taken into account by the Bidder in its bid. In order to afford prospective Bidders reasonable time in which to take the amendment into account in preparing their bid, the EESL may, at its discretion, extend the deadline for the submission of bids.

1.4 Cost of tender Documents

Interested bidders may download the RfP/ Bidding documents from the website/e-portal mentioned in the BDS.

While submitting the bid (in case RfP/Bidding documents are downloaded from EESL website), bidder shall submit Tender Document Cost/fee as per the details mentioned in BDS.

2. Preparation of Bids

2.1 Procedure for Submission of Bid/RfP.

Single Stage Two Envelope Bidding Process:

The Bidder shall submit their bids as Envelope-1 and Envelope-2. Two Envelopes should contain the details of the offer as follows:

Packet-1 of Envelope-I should contain (This envelope appears ONLINE in dynamic form in case of E-tenders)

- i. Bid Document Fee in the form of DD/Pay Order/Banker's Cheque (wherever applicable) or through online as per ITB sub clause 1.4.
- ii. Letter of the bidder submitting the bid in the form as stipulated in the bid document, i.e., as per Bid Form as **Attachment-1 of Section-6** (Forms& Procedures).
- iii. Bid Security/Earnest Money Deposit in the form of Banker's Cheque/Demand Draft/Pay order in favour of "Energy Efficiency Services Limited" or in the form of Bank Guarantee as prescribed format as **Attachment-2 of Section-6** (Forms& Procedures). (**Only EMD and Bid document fee related document to be submitted by post in sealed envelope superscribed with RfP/Tender reference in case of e-tender**).
- iv. Power of attorney to sign the bid as **Attachment-3 of Section-6** (Forms& Procedures). Bidders to use their own format.
- v. Certificate regarding acceptance of important terms and conditions as per ITB sub Clause No. 4.6 as **Attachment-4 of Section-6** (Forms& Procedures).
- vi. Deviation statement as per **Attachment-5 of Section-6** (Forms& Procedures).
- vii. Form of acceptance of EESL fraud prevention policy as per **Attachment-6 of Section-6** (Forms& Procedures).
- viii. An undertaking by Holding company (as applicable) as per **Attachment-7 of Section-6** (Forms& Procedures).
- ix. Format for Details regarding RTGS/NEFT Payments as per **Attachment-8 of Section-6**

NIT/Bid Document No.: EESL/06/24-25/SERC-Contracts/TS/CCMS - GHMC & ULB/OTE-232414, Date: 25/09/2024	SECTION -2 (ITB)	Page 5 of 19
--	---------------------	--------------

- x. (Forms& Procedures).
Compliance Matrix/ CHECK - LIST FOR BIDDERS as per **Attachment-9 of Section-6** (Forms& Procedures).
- xi. Certification regarding Declaration of Local content as per **Attachment-10 of Section-6** (Forms& Procedures).
- xii. Certification by the Bidder as per order no. F.No.6/18/2019-PPD dated 23/07/2020 issued by Public Procurement Division, Department of Expenditure, Ministry of Finance, Government of India (DoE Order) as per Attachment-11 of Section-6 (Forms& Procedures).
- xiii. Techno-commercial bid as indicated in bid document. Documentary evidence regarding bidder's qualifications to perform the contract as required in Qualifying Requirement as per Attachment-12 of Section-6 (Forms& Procedures).
- xiv. Declaration duly signed on Company Letter Head Pad with company's seal for not being under debar list/undergoing debarment period on account of breach of the code of integrity under rule 175(1)(i)(h) of general financial rules (Scanned Copy to be uploaded at E-tendering portal). Bidder shall clearly mention tender reference no. and date of signing the self-declaration as per Attachment-13 of Section-6 (Forms& Procedures).
- xv. Certificate regarding non debarment / blacklisting/disqualification as per Attachment-14 of Section-6 (Forms& Procedures).

Envelope-2 should contain Price Bid, shall comprise of (In case of E-tender Price bid is to be submitted ONLINE)

- i. Price Bid in the format prescribed in the tender document.

2.2 Cost of Bid/ RfP

The Bidder shall bear all costs associated with the preparation and submission of its Bid/RfP, including cost of presentation for the purposes of clarification of the bid, if so desired by the EESL. EESL will in no case be responsible or liable for those costs, regardless of the conduct or outcome of the tendering process.

2.3 Language of Bids

The proposal prepared by the bidder/consortium of bidders and all correspondence and documents relating to the Bid/RfP exchanged by the bidder/consortium of bidders and EESL, shall be written in English language, provided that any printed literature furnished by the bidder/consortium of bidders may be written in another language so long the same is accompanied by an English translation by authorized Translator in which case, for purposes of interpretation of the bid, the English translation shall govern.

2.4 Bid Security/Earnest Money Deposit (EMD)

Amount of Bid Security: Bid Security/Earnest Money deposit as mentioned in BDS is to be submitted. The bidder shall furnish, as part of its bid, a bid security in a separate envelope (ITB sub clause 2.1). The bid security shall, at the bidder's option, be in the form of a Banker's cheque, Demand Draft in favor of "Energy Efficiency Services Limited" payable at New Delhi or a bank guarantee as per format in Section 6. Bid security/EMD shall remain valid for a period of 45 days beyond the original bid validity period. If there is any extension in bid validity period, then EESL may ask the bidder to extend the validity of bid security.

Any bid not accompanied by an acceptable bid security, shall be rejected by EESL as being non-responsive and returned to the bidder without being opened. The bid security of a consortium must be in the name of all the partners in the consortium submitting the bid. If lead partner is mentioned in case of consortium, then bid security can be in the name of lead partner.

The bid securities of unsuccessful bidders will be returned as promptly as possible after the award is made to lowest evaluated bidder.

The bid security of the successful bidder will be returned when the bidder has signed the contract agreement, and has furnished the required performance security.

Please note that for Tender Conditions inter alia including exemption of tender fee, Bid Security etc. applicable for MSE and Start-ups, please refer Annexure-II:

The bid security may be forfeited if:

- a) If the bidder withdraws its bid during the period of bid validity as specified in the bid /RFP document. (Banning policy as per Annexure-IV of RfP document)
- b) If the bidder does not accept computational/arithmetical error correction made by EESL and as explained in "Financial Evaluation" section of the Bid/ RfP document.
- c) If the bidder does not accept assumptions, estimations etc. used for evaluation of bids as specified by EESL in tender documents and revision of his bid accordingly, in case other assumptions are used. If the bidder does not accept the sharing as specified in the bid.
- d) If the Bidder refuses to withdraw, without any cost to the EESL, any deviation not listed in Attachment 5 but found elsewhere in the bid; or
- e) In the case of successful bidder, if the bidder fails within the specified time limit:
 - To sign the contract agreement within 28 days of placement of LoI/Award letter.
 - To furnish the required performance security, in accordance with the tender document.

2.5 Power of Attorney as Attachment 3 of Section-6 in first envelope

A power of attorney duly authorized by a notary public, indicating that the person(s) signing the bid has/have the authority to sign the bid and thus the bid is binding upon the bidder during the full period of its validity in accordance with ITB sub clause 2.10.

2.6 Certificate Regarding Acceptance of Important Terms & conditions

NIT/Bid Document No.: EESL/06/24-25/SERC-Contracts/TS/CCMS - GHMC & ULB/OTE-232414, Date: 25/09/2024	SECTION -2 (ITB)	Page 7 of 19
---	---------------------	--------------

Please refer Part-A of BDS. Certificate Regarding Acceptance of Important Conditions as Attachment 4 is to be submitted in first envelope.

No deviation, other than mentioned in Deviation statement, is permitted by the EESL, to the provisions of the bidding documents listed in ITB sub-clause 4.6. The Bidders are advised that while making their bid proposals and quoting prices, these conditions may appropriately be taken into consideration. Bidders are required to furnish a certificate indicating their compliance to the provisions relating to the clauses listed in ITB sub-clause 4.6 in Attachment 4. Attachment 4 for acceptance of important conditions duly signed and stamped by the bidder is to be furnished in a separate sealed first envelope/Online. Any bid not accompanied by such certificate in a separate sealed first envelope/such certificate Online shall be rejected by the EESL and returned to the Bidder without being opened.

2.7 Deviations

if any, from the terms and conditions of bidding documents or technical specifications shall be listed only in **Attachment 5 of Section-6** to the bid. The Bidder shall also provide the additional price, if any, for withdrawal of the deviations. However, the attention of the bidders is drawn to the provisions of ITB sub clause 4.6 regarding the rejection of bids that are not substantially responsive to the requirements of the bidding documents.

Bidders may further note that except for the deviations listed in Attachment 5, the bid shall be deemed to comply with all the requirement in the bidding documents and the bidders shall be required to comply with all such requirements of bidding documents and technical specifications without any extra cost to the EESL irrespective of any mention to the contrary, anywhere else in the bid, failing which the bid security of the bidder may be forfeited.

At the time of award of contract, if so desired by the EESL, the bidder shall withdraw these deviations listed in Attachment-5 at the cost of withdrawal stated by him in his bid. In case the bidder does not withdraw the deviations proposed by him, if any, at the cost of withdrawal stated in the bid, his bid will be rejected and bid security forfeited.

2.8 Bid prices

Unless otherwise specified in the technical specifications, bidders shall quote for the entire facilities on a "single responsibility" basis such that the total bid price covers all the contractor's obligations mentioned in or to be reasonably inferred from the bidding documents in respect of the design, manufacture, including procurement and subcontracting (if any), delivery, construction, installation, survey cost, monitoring and verification cost and completion of the facilities including supply of mandatory spares or spares to be supplied during warranty (if any). This includes all requirements under the contractor's responsibilities for testing, pre - commissioning and commissioning of the facilities and, where so required by the bidding documents, the acquisition of all permits, approvals and licenses, etc.; the operation, maintenance and training services and such other items and services as may be specified in the bidding documents, all in accordance with the requirements of the General Conditions of Contract and Technical Specification.

Bidders are required to quote the price for the commercial, contractual and technical obligations outlined in the bidding documents. If a Bidder wishes to make a deviation to the provisions of the bidding documents, such deviations shall be listed in **Attachment 5 of Section-6** of its bid. The bidder shall also provide the additional price, if any, for withdrawal of the deviations, pursuant to ITB sub clause 2.7.

Bidders shall give a breakdown of the prices in the manner and detail called for in the price schedules.

2.9 Price Basis

Price quoted in the bid must be firm and shall remain firm during currency of the Contract. Hence prices in Letter of Award shall be firm and not subject to escalation till the execution of the complete order and its subsequent amendments accepted by the bidder even though the completion / execution of the order may take longer time than the delivery period specified and accepted in the Notification of Award.

Statutory variation in applicable GST shall only be on account of Employer in case bidder has shown the rates of present taxes in their bid and other prices quoted by the Bidder shall be fixed during the Bidder's performance of the Contract and not subject to variation on any account. Even in case prices asked in Bid price Schedule are quoted as inclusive of taxes, tax rates shall be shown separately. Bidders shall quote all prices in Indian Rupees only. Employer shall bear no responsibility on account of Taxes and Duties other than GST.

2.10 Period of Validity of Bid

Bids shall remain valid for a period of Six Months from opening of Bids mentioned in BDS. A bid valid for a shorter period may be rejected by the EESL as being non-responsive. In exceptional circumstances, the EESL may solicit the bidder's consent to an extension of the bid validity period. The request and response thereto shall be made in writing thro' letters/ e-mails. If the bidder accepts to prolong the period of validity, the bid security/EMD shall also be suitably extended. A bidder may refuse the request for Bid Validity Extension without forfeiting its bid security. A bidder granting the request will not be required nor permitted to modify its bid.

2.11 Format and Signing of Bid

The original copy of the bid, consisting of the documents listed in ITB sub Clause 2.1 shall be typed or written in indelible ink and shall be signed by the bidder or a person or persons duly authorized to bind the bidder to the contract. The authorization shall be indicated by written power of attorney accompanying the bid and submitted as **relevant attachment under Section-6** to the bid under ITB sub clause 2.1. All pages of the bid, except for un-amended printed literature, shall be initiated by the person or persons signing the bid.

Any interlineations, erasures or overwriting shall only be valid if they are initiated by the signatory to the bid.

2.12 Contents of the Bid/proposal

NIT/Bid Document No.: EESL/06/24-25/SERC-Contracts/TS/CCMS - GHMC & ULB/OTE-232414, Date: 25/09/2024	SECTION -2 (ITB)	Page 9 of 19
---	---------------------	--------------

The Bidder or consortium of bidders is expected to examine all instructions, forms, terms & conditions and scope of work in the RfP documents. Failure to furnish all information required or submission of a bid not substantially responsive to the RfP/Bidding Document in every respect will be at the bidder's risk and may result in the rejection of the bid.

2.13 Disclaimer

EESL and/or its officers, employees disclaim all liability from any loss or damage, whether foreseeable or not, suffered by any person acting on or refraining from acting because of any information including statements, information, forecasts, estimates or projections contained in this document or conduct ancillary to it whether or not the loss or damage arises in connection with any omission, negligence, default, lack of care or misrepresentation on the part of EESL and/or any of its officers, employees.

2.14 Authorized Signatory

The bidder used in the RfP document shall mean the one who has signed the bid document. The bidder should be the duly authorized representative of the bidder, for which a certificate of authority/power of attorney will be submitted along with the offer. This should clearly define the authority provided to the authorized representative. Complete offer, all certificates and documents (including reply to any clarifications sought and any subsequent correspondences) shall be furnished and signed on all pages by the authorized representative.

The power of attorney or authorization, or any other document consisting of adequate proof of the ability of the signatory to bind the bidder or consortium of bidders shall be annexed to the bid as Attachment 3 in Envelope 1. EESL may reject outright any proposal not supported by adequate proof of the signatory's authority.

2.15 Contact details of the Bidder

Bidder who wants to receive EESL's response to queries should give their contact details to EESL. The Bidder should send their contact details in writing at the EESL's contact address.

2.16 Taxes, Levies and Duties

Bidders are required to quote their prices inclusive of all taxes and duties except applicable GST. The Input Tax Credit (ITC) available, if any, under the GST Law as per the relevant Government policies wherever applicable shall be taken into account by the Bidder while quoting bid price. EESL's liability shall be only for applicable GST. Bidder is to arrange on its own to deliver the material at site. No road permit shall be provided by EESL.

3. Submission of Bids

3.1 Bids shall be submitted as per clause ITB sub clause 2.1 above and in line with the provisions of Annexure-I to this RfP Documents.

The Bidder shall upload the soft copy part of the bid as per the provisions of the e-portal (refer ITB sub clause 2.1 above) and submit the hard copy of documentary evidence towards Document fee or documentary evidence in support of exemption of Document fee (as applicable), Bid Security or documentary evidence in support of exemption of Bid Security (as applicable).

The envelope in hard copy shall

- (a) be addressed to the Employer at the address given in this RfP Documents, and
- (b) bear the tender name, the Invitation for Bids title and number indicated in the BDS, and the statement “Do Not Open Before [date],” to be completed with the time and date specified.

All the envelopes shall also indicate the name and address of the Bidder. If the envelope is not sealed and marked as required, the Employer will assume no responsibility for the bid’s misplacement or premature opening.

3.2 Deadline for Submission of Bids

Bids must be received at the address specified in the BDS but no later than the time and date stated in the BDS. In the event of the specified date for submission of bids being declared a holiday for the EESL, the bids will be received up to the appointed time on the next working day.

The EESL may, at its discretion, extend this deadline for submission of bids by amending the bidding documents in accordance with ITB sub clause 1.3, in which case all rights and obligations of EESL and bidders will thereafter be subject to the deadline as extended.

3.3 Late Bids

The bidder shall not be permitted to submit the soft copy part of the bid by any mode other than uploading on the portal within the specified deadline for submission of bids. The e-Procurement system would not allow any late submission of bids through the portal after due date & time as specified in ITB sub clause 3.2.

In case Hard copy part of the bid is received by the Employer after the deadline for submission of the same prescribed by the Employer in the ITB sub clause 3.2, but the bidder has uploaded the soft copy part of the bid, the bid will be considered as late bid. In such a case, the soft copy part of the first envelope bid uploaded on the portal shall be opened in line with the provisions of Bidding Documents. Such bids will be rejected during preliminary examination. However, in case of MSEs who are exempted from submission of Document fee and Bid security in line with Annexure-II, submission of hard copy part after the deadline for submission of the same prescribed by the Employer in the ITB sub clause 3.2, shall not lead to outright rejection of the bid., but the documents required to be submitted in the hard copy part shall be sought through clarifications as brought out at ITB sub clause 4.2.

No bid may be withdrawn in the interval between the bid submission deadline and the expiration of the bid validity period specified in ITB sub clause 2.10. Withdrawal of a bid during this interval may result in the Bidder’s forfeiture of its bid security, pursuant to ITB sub clause 2.4.

4. Bid Opening and Evaluation

4.1 Bid Opening Process

The Employer will open the Envelope -1 (First Envelope) i.e. Techno – Commercial Part in public in the presence of bidders’ designated representatives who choose to attend, at the time, date, and location stipulated in the ITB sub clause 3.2. The bidders’ representatives who are present shall sign a register evidencing their attendance. Bidder who have submitted their bid may view on line tender opening on the portal from their end. In the event of the specified date for the submission of bids being declared a holiday for the Employer, the bids will be received upto the appointed time on the next working day.

The bidders’ names, the presence of bid security, and any such other details as the Employer may consider appropriate, will be get declared through the Portal by the Employer. However, opening of bid, whether or not accompanied with the Tender fee and/or bid security, shall not be construed to imply its acceptability which shall be examined in detail pursuant to the provisions contained in the Section-2 & 3.

The Employer shall prepare minutes of the bid opening in the form of Bid Opening Statement, including the information disclosed to those present.

Bids not opened at bid opening shall not be considered further for evaluation, irrespective of the circumstances and shall be send to archive unopened

4.2 Clarification on Bids

During bid evaluation, the EESL may, at its discretion, ask the bidder for a clarification of its bid as per the BDS. The request for clarification and the response shall be in writing, and no change in the price or substance of the bid shall be sought, offered or permitted. The address for communication will be same as ITB sub clause 1.2.

4.3 Preliminary Examination of Bids

The Employer will examine the bids to determine whether they are complete, whether required sureties have been furnished, whether the documents have been properly signed, and whether the bids are generally in order.

In case of non-submission of bid in the portal (soft copy part of the bid) within the stipulated deadline, then even if the bidder has submitted the specific documents in hard copy part in original within the stipulated deadline pursuant to ITB sub clause 3.2 its bid shall be considered as incomplete bid, which shall be summarily rejected. Similarly, in case of non-submission of Hard copy part of the bid, but the bidder has uploaded the soft copy part of the bid, the bid will be considered as incomplete bid. In such a case, the soft copy part of the first envelope bid uploaded on the portal shall be opened. Such bids will be rejected during preliminary examination. However, in case of MSEs who are exempted from submission of tender fee and Bid Security, non-submission of Hard copy part shall not lead to outright rejection of the bid.

4.4 Arithmetical errors rectification process

NIT/Bid Document No.: EESL/06/24-25/SERC-Contracts/TS/CCMS - GHMC & ULB/OTE-232414, Date: 25/09/2024	SECTION –2 (ITB)	Page 12 of 19
--	---------------------	---------------

Arithmetical errors will be rectified on the following basis. If there is a discrepancy between the unit price and the total price, which is obtained by multiplying the unit price and quantity, or between sub totals and the total price, the unit or subtotal price shall prevail, and the total price shall be corrected. If there is a discrepancy between words and figures, the amount in words will prevail. If the Bidder does not accept the correction of errors, its bid will be rejected and the bid security will be forfeited in accordance with ITB sub clause 2.4.

The EESL may waive any minor informality, nonconformity or irregularity in a bid that does not constitute a material deviation, whether or not identified by the bidder in Attachment 4 to its bid, and that does not prejudice or affect the relative ranking of any bidder as a result of the technical and commercial evaluation, pursuant to ITB sub clauses 4.7 and 4.8.

4.5 Preliminary Evaluation

Prior to the detailed evaluation, the EESL will determine whether each bid is of acceptable quality, is generally complete and is substantially responsive to the bidding documents. For purposes of this determination, a substantially responsive bid is one that conforms to all the terms, conditions and specifications of the bidding documents without material deviations, objections, conditionality's or reservations. A material deviation, objection, conditionality or reservation is one (i) that affects in any substantial way the scope, quality or performance of the contract; (ii) that limits in any substantial way, inconsistent with the bidding documents, the EESL's rights or the successful bidder's obligations under the contract; or (iii) whose rectification would unfairly affect the competitive position of other bidders who are presenting substantially responsive bids.

4.6 Acceptance of Important Condition

No deviation, whatsoever, is permitted by the EESL to the provisions relating to the following clauses (Important Conditions). Party is to submit the following as **Attachment 4 of Section-6** in Envelope 1:

Governing Laws	-	Clause 5 of GCC
Settlement of Disputes	-	Clause 6 of GCC
Terms of payment	-	Clause 12.0 of GCC
Contract Performance Security	-	Clause 13.3 of GCC
Taxes and Duties	-	Clause 14 of GCC
Completion Time Guarantee	-	Clause 26 of GCC
Defects Liability	-	Clause 27 of GCC
Functional Guarantee	-	Clause 28 of GCC
Patent Indemnity	-	Clause 29 of GCC
Limitations of Liability	-	Clause 30 of GCC
Project information, Estimation,	-	As per Tables in price bid Assumptions and conditions for Evaluation

Bidders are required to furnish a certificate as per Attachment 4, indicating their compliance to the provisions of the above clauses.

At the time of award of contract, if so desired by the EESL the bidder shall withdraw the deviations listed in attachment 5 at the cost of withdrawal stated by him, in his bid. In case the bidder does not withdraw the deviations proposed by him in Attachment 5 to his bid, if any; at the cost of withdrawal stated in his bid, his bid will be rejected and security will be forfeited.

The EESL's determination of a bid's responsiveness is to be based on the contents of the bid itself without recourse to extrinsic evidence. If a bid is not substantially responsive, it will be rejected by the EESL, and may not subsequently be made responsive by the bidder by correction of the nonconformity.

4.7 Technical Evaluation

The EESL will carry out a detailed evaluation of the bids previously determined to be substantially responsive in order to determine whether the technical aspects are in accordance with the requirements set forth in the bidding documents. In order to reach such a determination, the EESL will examine and compare the technical aspects of the bids on the basis of the information supplied by the bidders, taking into account the following factors:

- a) Overall completeness and compliance with the technical specifications and drawings; deviations from the technical specifications as identified in Attachment 5 to the bid; suitability of the facilities offered in relation to the environmental and climatic conditions prevailing at the site; and quality, function and operation of any process control concept included in the bid. The bid that does not meet minimum acceptable standards of completeness, consistency and detail will be rejected for non- responsiveness.
- b) Achievement of specified performance criteria by the facilities as per scope of work
- c) Type, quantity and long-term availability warranty spare parts and also mandatory and recommended spare parts and maintenance services.
- d) Any other relevant factors, if any, listed in the tender document, or that the EESL deems necessary or prudent to take into consideration.

4.8 Commercial Evaluation

The EESL's evaluation of a bid will take into account, in addition to the bid prices indicated in price schedules in section 4 along with the corrections pursuant to ITB sub clause 4.3, the following costs and factors that will be added to each bidder's bid price in the evaluation using pricing information available to the EESL, in the manner and to the extent indicated in ITB sub clause 4.9 and in the technical specifications:

- a) The cost of all quantifiable deviations and omissions from the contractual and commercial conditions and the technical specifications as identified in Attachment 5 to the Bid.
- b) Compliance with the time schedule called for and evidenced as needed in a milestone schedule provided in the bid.
- c) The functional guarantees of the facilities offered as per scope of work.
- d) The extra cost of work, services, facilities etc, required to be provided by the EESL of third parties.

4.9 Evaluations of Deviations

Pursuant to ITB Sub-Clause 4.8, the following evaluation methods will be followed:

NIT/Bid Document No.: EESL/06/24-25/SERC-Contracts/TS/CCMS - GHMC & ULB/OTE-232414, Date: 25/09/2024	SECTION -2 (ITB)	Page 14 of 19
--	------------------	---------------

a) Technical and Commercial Deviations

The evaluation shall be based on the evaluated cost of fulfilling the contract in compliance with all commercial, contractual and technical obligations under this bidding document. In arriving at the evaluated cost, the price for withdrawal of deviations shown in Attachment 5 to the bid will be used if necessary. If such a price is not given in Attachment-5, the EESL will make its own assessment of the cost of such a deviation for the purpose of ensuring fair comparison of bids.

b) Time schedule (program of performance)

The plant and equipment covered by this bidding are required to be transported/ shipped and installed, and the facilities are to be completed within the period as mentioned below.

Completion of all facilities/work: As per year/months indicated in SCC.

The above date will be the effective date specified in the contract agreement. Bidders are required to base their prices on the time schedule or, where no time schedule is given, on the completion date(s) given above. No credit will be given for earlier completion.

The master network and the key milestone dates will be discussed with the successful bidder and agreed upon in pre-award discussion before issuance of Letter of Award. Engineering drawing and data submission schedule shall also be discussed and finalized before the issuance of Letter of Award.

After the Letter of Award, the contractor shall plan the sequence of work manufacture, supply, installation to meet the above stated dates of successful completion of facilities and shall ensure all work, manufacture, shop testing, inspection and shipment of the equipment in accordance with the required sequence.

c) Functional Guarantees of the facilities (if Applicable)

Bidders shall state the functional guarantees (e.g. performance, efficiency, consumption) of the proposed facilities in response to the technical specifications. In case a minimum (or a maximum, as the case may be) level of functional guarantees is specified in the technical specifications for the bids to be considered responsive, bids offering plant and equipment with such functional guarantees less (or more) than the minimum (or maximum) specified shall be rejected.

d) Work, services, facilities etc., to be provided by the EESL

Where bids include the undertaking of work or the provision of services or facilities by the EESL in excess of the provisions allowed for in the bidding documents, the EESL shall assess the costs of such additional work, services and/or facilities during the duration of the contract. Such costs shall be added to the bid price for evaluation.

4.10 Opening of Second Envelope

The Second Envelope i.e., Price Part of only those Bidders shall be opened who are determined as having submitted substantially responsive bids and are ascertained to be qualified to satisfactorily perform the Contract. Such Bidders shall be intimated through portal only about the date and time for opening of Price Part i.e., Envelope-2 (Second Envelope) of the Bids by the Employer. A negative determination of the bids shall be notified by the Employer to such Bidders through portal only and the Second Envelope submitted by them shall be sent to archive unopened and the bid security shall be returned.

The Price Part containing any deviations and omissions from the contractual and commercial conditions and the Technical Specifications which have not been identified in the First Envelope are liable to be rejected

- (a) The Employer's evaluation of a bid will take into account, in addition to the bid prices indicated in online Price Schedule (Second Envelope), the following costs and factors that will be added to each Bidder's bid price in the evaluation using pricing information available to the Employer, in the manner and to the extent indicated herein and in the Technical Specifications:
- (b) the cost of all quantifiable deviations and omissions from the contractual and commercial conditions and the Technical Specifications as identified in the evaluation of First Envelope, and other deviations and omissions not so identified;
- (c) any other relevant factors listed in this RfP Documents.

Pursuant to aforesaid, the evaluation shall be based on the evaluated cost of fulfilling the contract in compliance with all commercial, contractual and technical obligations under this Bidding Documents. In arriving at the evaluated cost, towards deviations whether material or minor identified in the evaluation of First Envelope, the cost of withdrawal indicated by the bidder in Attachment-5 of the First Envelope will be used. If such a price is not given except for material deviation, the Employer will make its own assessment of the cost of such a deviation for the purpose of ensuring fair comparison of bids. In those cases, where the bidder has taken a material deviation but has not indicated the cost of withdrawal, the bid shall be treated as non-responsive and shall not be considered further.

4.11 Contacting the Employer

Subject to GCC Clause 20, no Bidder shall contact the Employer on any matter relating to its bid, from the time of the opening of bids to the time the contract is awarded.

Information relating to the examination, evaluation and comparison of bids and recommendations for the award of contract shall not be disclosed to bidders or any other persons not officially concerned with such process until the award to the successful bidder has been announced. Any effort by a Bidder to influence the Employer in the Employer's bid evaluation, bid comparison or contract award decisions may result in rejection of the Bidder's bid.

5. Award of Contract

5.1 Award criteria

NIT/Bid Document No.: EESL/06/24-25/SERC-Contracts/TS/CCMS - GHMC & ULB/OTE-232414, Date: 25/09/2024	SECTION -2 (ITB)	Page 16 of 19
--	------------------	---------------

Subject to ITB Clause 5.5, the EESL will award the contract to the successful Bidder whose bid has been determined to be substantially responsive and to be the lowest evaluated technically acceptable bid or bid offering highest return to EESL as the case may be as per RfP/Bidding documents, further provided that the Bidder is determined to be qualified to perform the contract satisfactorily.

Except for the deviations listed in Attachment-5, the bidder would be required to comply with all the requirements of bidding documents without any extra cost to EESL failing which his bid security will be forfeited. Further, the EESL may request the bidder to withdraw any or all of the deviations listed in Attachment - 5 to the winning bid, at the price shown for the deviation in Attachment 5 to the bid. In case the bidder does not withdraw the deviations proposed by him, if any, at the cost of withdrawal stated in the bid, his bid will be rejected and bid security forfeited.

The mode of contracting with the Successful Bidder will be as per stipulation briefly indicated below:

Single Contract shall be placed for following Price Components:

- a) For supply of plant and equipment;
- b) For providing all services i.e. inland transportation for delivery at site, inland transit insurance, unloading, storage, handling at site, installation (including civil. Structural steel work & allied work, if applicable) insurance covers other than inland transit insurance, erection, testing & commissioning, in respect of all the Goods supplied under the 'First Contract' and all other
- c) Any other Services as specified in the Contract Documents.

5.2 EESL's right to accept any bid and to reject any or all bids

The EESL reserves the right to accept or reject any bid, and to annul the bidding process and reject all bids at any time prior to award of contract, without thereby assigning any reason thereof and incurring any liability to the affected Bidder or bidders or any obligation to inform the affected Bidder or bidders of the grounds for the EESL's action.

5.3 Notification of Award

Prior to the expiration of the period of bid validity, the EESL will notify the successful bidder in writing by issuing Notification of Award (NOA) either through telefax/ scanned e-mail or through registered/speed post/couriered letter, that its bid /offer has been accepted. The Notification of Award (NOA) will constitute the formation of the contract.

The bidder shall return duplicate copy of the NoA/contract and the other enclosed documents duly signed as a token of acknowledgement, within 07 days from the date of receipt of this order. Bidder is to make two original copies of Contract Agreement as per the format attached in the RfP Documents. Upon the successful bidder's furnishing of the performance security pursuant to ITB Clause 5.6, the EESL will promptly notify each unsuccessful bidder and will discharge its bid security.

5.4 Cancellation

EESL reserves the rights to cancel the order in the part or in full by giving one-week advance notice thereby if-

- The bidder fails to comply with any of the terms of the order.
- The bidder becomes bankrupt or goes in to liquidation.
- The bidder makes general assignment for the benefit of the creditors and any receiver is appointed for the property owned by the bidder.

5.5 Modifications

This order constitutes an entire agreement between the parties hereto. Any modifications to this Order shall become binding only upon the same being confirmed in writing duly signed by both the parties.

5.6.1 Signing the Contract Agreement

At the same time as the EESL notifies the successful Bidder that its bid has been accepted, the EESL will send the bidder the contract agreement provided in the bidding documents, incorporating all agreements between the parties.

5.6 Contract Performance Security

Within twenty-eight (28) days after receipt of the Notification of Award, the successful bidder shall furnish the performance security for five percent (5% cost of Installation + 5% cost of maintenance for one year + 5% cost of IDC) of the contract price or as specified in RfP/Bidding Documents and in the form provided in the section "Forms and Procedures" of the bidding documents or in another form acceptable to the EESL.

In case Joint Deed(s) of Undertaking by the Contractor along with his associate(s)/collaborator(s) form part of the Contract, then, unconditional Bank Guarantee(s) from such associate(s)/collaborator(s) for amount(s) specified in Bid

Failure of the successful Bidder to comply with the requirements of ITB Clause 5.4 and/ or Clause 5.6 shall constitute sufficient grounds for the annulment of the award and forfeiture of the bid security, in which event the EESL may make the award to the next lowest evaluated bidder or call for new bids.

5.7 Corrupt or Fraudulent practices

The EESL requires that bidders observe the highest standard of ethics during the procurement and execution of such contracts. In pursuance of this policy, the EESL: defines, for the purposes of this provision, the terms set forth below as follows:

- a. "corrupt practice" means the offering, giving, receiving or soliciting of anything of value to influence the action of a public official in the procurement process or in contract execution; and

- b. "fraudulent practice" means a misrepresentation of facts in order to influence a procurement process or the execution of a contract to the detriment of the EESL, and includes collusive practice among bidders (prior to or after bid submission) designed to establish bid prices at artificial non-competitive levels and to deprive the EESL of the benefits of free and open competition;
- c. will reject a proposal for award if it determines that the bidder recommended for award has engaged in corrupt or fraudulent practices in competing for the contract in question;
- d. will declare a firm ineligible, either indefinitely or for a stated period of time, to be awarded a contract if it at any time determines that the firm has engaged in corrupt or fraudulent practices in competing for, or in executing, a contract of the EESL (as per Annexure-IV of RfP Document)

5.8 Ineligibility for Future Tenders

Notwithstanding the provisions specified in ITB sub clause 2.4 and ITB sub clause 5.4 and 5.5, if a bidder after having been issued a Notification of Award, either does not sign the Contract Agreement pursuant to ITB sub clause 5.5 and/or does not submit an acceptable Contract Performance Security pursuant to ITB sub clause 5.6, such bidder may be considered ineligible for participating in future tenders of EESL for a period as may be decided by the EESL.

Successful bidder is to submit interchangeability certificate for its product supplied for replacement during warranty and maintenance period and even when it is purchased from open market. In case due to change in technology, the supplied product is not available during warranty/ maintenance period than the improved version of product can be used in warranty/ maintenance period with same or improved technical parameters or the combination thereof after written communication of Engineer in Charge at same cost & terms and conditions. Successful Bidder, on whom letter of award has been placed, has also to confirm that the prices of improved version of product is not lesser than the original product or its parts in comparison.

SECTION-3

GENERAL CONDITIONS OF CONTRACT (GCC)

1. Contract and Interpretation

Definitions

The following words and expressions shall have the meanings hereby assigned to them:

“Contract” means the Contract Agreement entered into between the EESL and the Implementing Partner, together with the Contract Documents referred to therein; they shall constitute the Contract, and the term “the Contract” shall in all such documents be construed accordingly.

“Contract Documents” means the documents listed in Article. 1.1 (Contract Documents) of the Form of Contract Agreement (including any amendments thereto).

“GCC” means the General Conditions of Contract hereof.

“SCC” means the Special Conditions of Contract.

“Day” means calendar day of the Gregorian calendar. “Month” means calendar month of the Gregorian calendar.

“Employer” means EESL, New Delhi and includes the legal successors or permitted assigns of the EESL.

“Project Manager” means the person appointed by the EESL in the manner provided in GCC Sub-Clause 17.1 (Project Manager) hereof and named as such in the SCC to perform the duties delegated by the EESL.

“Contractor or Implementing Partner or successful Contractor” means the person(s) whose bid to perform the Contract has been accepted by the EESL and is named as such in the Contract Agreement, and includes the legal successors or permitted assigns of the Implementing Partner.

“Contractor or Implementing Partner’s Representative” means any person nominated by the Implementing Partner and approved by the EESL in the manner provided in GCC Sub- Clause 17.2 (Implementing Partner’s Representative and Construction Manager) hereof to perform the duties delegated by the Implementing Partner.

“Sub-Contractor or Sub Implementing Partner,” including vendors, means any person to whom execution of any part of the Facilities, including preparation of any design or supply of any Plant and Equipment, is sub-contracted directly by the Contractor or Implementing Partner, and includes its legal successors or permitted assigns.

“Contract Price” means the sum specified in Article 2.1 (Contract Price) of the Contract Agreement, subject to such additions and adjustments thereto or deductions there from, as may be made pursuant to the Contract.

“Facilities” means the Plant and Equipment to be supplied and installed, as well as all the Installation Services to be carried out by the Implementing Partner under the contract.

“Plant and Equipment” means permanent plant, equipment, machinery, apparatus, articles and things of all kinds to be provided and incorporated in the Facilities by the Implementing Partner under the Contract (including the spare parts to be supplied by the Implementing Partner under GCC Sub-Clause 7.3 here-of), but does not include Implementing Partner’s Equipment.

“Installation Services” means all those services ancillary to the supply of the Plant and Equipment for the Facilities, to be provided by the Implementing Partner under the Contract; e.g., transportation and provision of marine or other similar insurance, inspection, expediting, Site preparation works (including the provision and use of Implementing Partner’s Equipment and the supply of all construction materials required), installation, testing, pre-commissioning, commissioning, operations, maintenance, the provision of operations and maintenance manuals, training of EESL's Personnel etc.

“Contractor or Implementing Partner’s Equipment” means all plant, facilities, equipment, machinery, tools, apparatus, appliances or things of every kind required in or for installation, completion and maintenance of Facilities that are to be provided by the Implementing Partner, but does not include Plant and Equipment, or other things intended to form or forming part of the Facilities.

“Site” means the land and other places upon which the Facilities are to be installed, and such other land or places as may be specified in the Contract as forming part of the Site or site of EESL’s client.

“Effective Date” means the date from which the Time for Completion shall be determined as stated in Article 3 (Effective Date for Determining Time for Completion) of the Form of Contract Agreement.

“Time for Completion” means the time within which Completion of the Facilities as a whole (or of a part of the Facilities where a separate Time for Completion of such part has been prescribed) is to be attained in accordance with the stipulations in the SCC and the relevant provisions of the Contract.

“Completion” means that the Facilities (or a specific part thereof where specific parts are specified in the SCC) have been completed operationally and structurally and put in a tight and clean condition, and that all work in respect of Pre-commissioning of the Facilities or such specific part thereof has been completed; and Commissioning has been attained as per Technical Specifications.

“Pre-commissioning” means the testing, checking and other requirement specified in the Technical Specifications that are to be carried out by the Implementing Partner in preparation for Commissioning as provided in GCC Clause 24 (Completion) hereof.

Commissioning” means trial/initial operation of the Facilities or any part thereof by the Implementing Partner, which operation is to be carried out by the Contractor as provided in GCC Sub-Clause 25.1 (Commissioning) hereof, for the purpose of carrying out Guarantee Test(s).

“Guarantee Test(s)” means the test(s) specified in the Technical Specifications to be carried out to ascertain whether the Facilities or a specified part thereof is able to attain the Functional Guarantees specified in the Technical Specifications in accordance with the provisions of GCC Sub Clause 25.2 (Guarantee Test) hereof.

Operational Acceptance” means the acceptance by the EESL of the Facilities (or any part of the Facilities where the Contract provides for acceptance of the Facilities in parts), which certifies the Implementing Partner’s fulfilment of the Contract in respect of Functional Guarantees of the Facilities (or the relevant part thereof) in accordance with the provisions of GCC Clause 28 (Functional Guarantees) hereof and shall include deemed acceptance in accordance with GCC Clause 25 (Commissioning and Operational Acceptance) hereof.

Defect Liability Period” means the period of validity of the warranties given by the Implementing Partner commencing at Completion of the Facilities or a part thereof, during which the Implementing Partner is responsible for defects with respect to the Facilities (or the relevant part thereof) as provided in GCC Clause 27 (Defect Liability) hereof.

2. Contract Documents

- 2.1 Subject to Article 1.2 (Order of Precedence) of the Contract Agreement all documents forming part of the Contract (and all parts thereof) are intended to be correlative, complementary and mutually explanatory. The Contract shall be read as a whole.
- 2.2 The Contract will be signed in three originals and the Implementing Partner shall be provided with one signed original and the rest will be retained by the EESL.
- 2.3 The Implementing Partner shall provide free of cost to the EESL all the engineering data, drawing and descriptive materials submitted with the bid, in at least five (5) copies to form a part of the Contract immediately after Notification of Award/ letter of Award.
- 2.4 Subsequent to signing of the Contract, the Implementing Partner at his own cost shall provide the EESL with at least five (05) true copies of Contract Agreement within thirty (30) days after signing of the Contract.

3. Interpretation

3.1 Language

NIT/Bid Document No.: EESL/06/24-25/SERC-Contracts/TS/CCMS - GHMC & ULB/OTE-232414, Date: 25/09/2024	SECTION – 3 GCC	Page 3 of 61
--	--------------------	--------------

- 3.1.1 Unless the Implementing Partner is a national of the EESL's country and the EESL and the Implementing Partner agree to use the local language, all Contract Documents, all correspondence and communications to be given, and all other documentation to be prepared and supplied under the Contract shall be written in English, and the Contract shall be construed and interpreted in accordance with that language.
- 3.1.2 If any of the Contract Documents, correspondence or communications are prepared in any language other than the governing language under GCC Sub-Clause 3.1.1 above, the English translation of such documents, correspondence or communications shall prevail in matters of interpretation.

3.2 Singular and Plural

The singular shall include the plural and the plural the singular, except where the context otherwise requires.

3.3 Headings

The headings and marginal notes in the General Conditions of Contract are included for ease of reference, and shall neither constitute a part of the Contract nor affect its interpretation.

3.4 Persons

Words importing persons or parties shall include firms, corporations and government entities.

3.5 Inco terms

Unless inconsistent with any provision of the Contract, the meaning of any trade term and the rights and obligations of parties there under shall be as prescribed by Incoterms.

Inco terms means international rules for interpreting trade terms published by the International Chamber of Commerce (latest edition), 38 Courts Albert 1er, 75008 Paris, France.

3.6 Construction of the Contract

3.6.1 The Contracts to be entered into between the EESL and the successful Contractor shall be as under:

- (i) First Contract: For Ex-works (India) supply of plant and equipment and accessories by Contractor including mandatory spares and spares to be supplied during warranty.
- (ii) Second Contract: for providing all services i.e. loading, inland/air/shipment transportation for delivery at site, inland/air/shipment transit insurance, unloading, storage, handling at site, installation, insurance covers other than inland transit insurance, testing, commissioning and conducting Guarantee tests in respect of all the equipment's supplied under the 'First Contract' and all other services including civil works, if any, as specified in the Contract Documents including sales tax and duties as asked in price bid in section IV. It will also cover cost for Repair and Maintenance and equipment's and/or additional warranty, where ever asked for supplied under the 'First Contract' and all other services including civil works, if any, as specified in the Contract Documents. All items in second contract must be quoted including service tax.

(iii) Third Contract: For providing all services including Awareness programme for public/stake holders/workshops/printing brochure and other materials, Survey cost, Monitoring and verification cost, scrap disposal cost, arrangement of office at both sites and Statuary agencies cost including service tax.

In case, value of second contract viz transportation, insurance is lower or the supply cost includes transportation, insurance etc than three contracts may be merged in two contract.

Arbitration:

1. Appointing authority for Arbitrator: CEO, EESL
2. The place of arbitration shall be: New Delhi

Prices are to be quoted as Firm during currency of contract. No price adjustment is allowed.

General:

1. In case of investment partner, A project manager is to be deputed from their side for co-ordinating activities.
 2. Word Implementing Partner for any Project used in General Conditions of contract includes persons of Investment partner, executing and implementing agencies etc.
 3. Notification of award means Letter of Intent and Letter of award
- 3.6.2 The award of separate Contracts shall not in any way dilute the responsibility of the Implementing Partner for the successful completion of the Scope of Work/Facilities as per Contract Documents and a breach in one Contract shall automatically be construed as a breach of the other Contract(s) which will confer a right on the EESL to terminate the other Contract(s) also at the risk and the cost of the Implementing Partner.

3.6.3 Set -Off Clause

Contractor irrevocably and unequivocally agrees that breach in this Contract shall constitute (deemed to be) a breach in other contracts entered by the Contractor with EESL (regardless of the scope of work) which will confer a right on EESL, among other rights available under the Contract or at law to terminate the other contracts at the risk and the cost of the contractor /Implementing Partner for the Project, for which awards have been made. For the avoidance of doubt, default in this Contract by the Contractor shall be a deemed default in other contract (awarded under separate RFPs) and EESL reserve the right to effectuate or avail all the remedies available under that contract.

3.7 Entire Agreement

Subject to GCC Sub-Clause 16.4 hereof, the Contract constitutes the entire agreement between the EESL and Implementing Partner with respect to the subject matter of Contract and supersedes all communications, negotiations and agreements (whether written or oral) of parties with respect thereto made prior to the date of Contract.

3.8 Amendment

No amendment or other variation of the Contract shall be effective unless it is in writing, is dated, expressly refers to the Contract, and is signed by a duly authorized representative of each party here to.

3.9 Independent Contractor or Implementing Partner

The Implementing Partner shall be an independent Implementing Partner performing the Contract. The Contract does not create any agency, partnership, joint venture or other joint relationship between the parties here to.

Subject to the provisions of the Contract, the Contractor or Implementing Partner shall be solely responsible for the manner in which the Contract is performed. All employees, representatives or Sub Contractor or Sub Implementing Partners engaged by the Implementing Partner in connection with the performance of the Contract shall be under the complete control of the Implementing Partner and shall at all times and for all purposes be deemed to be the employees of the Contractor and no relation of employer- employee or master-servant shall be understood to exist between the said manpower deployed or provided under this Agreement by the Contractor and EESL, at any point in time. For the sake of clarity, employees of the Contractor and the Sub-Contractor of the Contractor in no case shall be treated as the employees of EESL at any point of time. Further nothing contained in the Contract or in any subcontract awarded by the Implementing Partner shall be construed to create any contractual relationship between any such employees, representatives or Sub Contractor or Sub Implementing Partners and the EESL.

Contractor and Contractor's sub-contractors shall always abide by all existing labour enactment and rules made thereunder, regulations, notifications and bye laws of the State or Central Government or local authority and any other labour law (including rules) regulations, bye laws that may be passed or notification that may be issued under any labour law in future either by the State or Central Government or the local authority. Contractor shall keep EESL indemnified in case any action is taken against EESL. If EESL is caused to pay or incur any cost or liability or expense as may be necessary to cause or observe, or for non-observance of the provisions stipulated in the notifications/bye laws/Acts/Rules/regulations including amendments, if any, on the part of the Contractor. EESL shall have the right to deduct any money due to the Contractor including the amount of performance security. EESL shall also have right to recover from the Contractor any sum required or estimated to be required for making good the loss or damage suffered by EESL.

For the avoidance of doubt, Contractor shall indemnify EESL against any liability arising out of non-compliance of labour laws or any other law or any act of its employees during the deployment under this contract.

3.10 Joint Venture Agreement or Consortium

If the Implementing Partner is a joint venture or consortium of two or more firms, all such firms shall be jointly and severally bound to the EESL for the fulfilment of the provisions of the Contract and shall designate one of such firms to act as a leader with authority to bind the joint venture or consortium.

The composition or the constitution of the joint venture or consortium shall not be altered without the prior written consent of the EESL.

EESL is not obligated to file its claim or initiate legal proceedings first against the Lead Contractor pursuant to the Joint Venture Agreement or Consortium. EESL as per its sole discretion; also reserve the right to initiate the legal proceeding against the non-lead Contractor (or against all the members) pursuant to the Joint Venture Agreement or Consortium.

3.11 Non-Waiver

3.11.1 Subject to GCC Sub-Clause 3.11.2 below, no relaxation, forbearance, delay or indulgence by either party in enforcing any of the terms and conditions of the Contract the granting of time by either party to the other shall prejudice, affect or restrict the rights of that party under the Contract, nor shall any waiver by either party of any breach of Contract operate as waiver of any subsequent or continuing breach of Contract.

3.11.2 Any waiver of a party's rights, powers or remedies under the Contract must be in writing, must be dated and signed by an authorized representative of the party granting such waiver, and must specify the right and the extent to which it is being waived.

3.12 Severability

If any provision or condition of the Contract is prohibited or rendered invalid or unenforceable, such prohibition, invalidity or unenforceability shall not affect the validity or enforceability of any other provisions and conditions of the Contract.

3.13 Country of Origin

"Origin" means the place where the materials, equipment and other supplies for the Facilities are mined, grown, produced or manufactured, and from which the services are provided.

4. Notices

4.1 Unless otherwise stated in the Contract, all notices to be given under the Contract shall be in writing, and shall be sent by personal delivery, airmail post, special courier, cable, telegraph, telex, facsimile or Electronic Data Interchange (EDI) to the address of the relevant party set out in the Contract Coordination Procedure to be finalized pursuant to GCC Sub-Clause 17.2.3.1, with the following provisions.

4.1.1 Any notice sent by cable, telegraph, facsimile or shall be confirmed within two (2) days after dispatch by notice sent by airmail/ post or special courier, except as otherwise specified in the Contract.

- 4.1.2 Any notice sent by airmail post or special courier shall be deemed (in the absence of evidence of earlier receipt) to have been delivered ten (10) days after dispatch. In proving the fact of dispatch, it shall be sufficient to show that the envelope containing such notice was properly addressed, stamped and conveyed to the postal authorities or courier service for transmission by airmail or special courier.
- 4.1.3 Any notice delivered personally or sent by telegraph, facsimile shall be deemed to have been delivered on date of its dispatch.
- 4.1.4 Either party may change its postal, cable, telex, facsimile or EDI address or addressee for receipt of such notices by ten (10) days' notice to the other party in writing.
- 4.2 Notices shall be deemed to include any approvals, consents, instruction orders and certificates to be given under the Contract.

5. Governing Law

The Contract shall be governed by and interpreted in accordance with laws in force in India. The Courts of Delhi shall have exclusive jurisdiction in all matters arising under the Contract.

6. Settlement of Disputes

Following shall be the mechanism(s) for settlement of disputes:

6.1 Adjudicator

- 6.1.1 If any dispute of any kind whatsoever shall arise between the EESL and the Implementing Partner in connection with or arising out of the Contract, including without prejudice to the generality of the foregoing, any question regarding its existence, validity or termination, or the execution of the Facilities—whether during the progress of the Facilities or after their completion and whether before or after the termination, abandonment or breach of the Contract—the parties shall seek to resolve any such dispute or difference by mutual consultation. If the parties fail to resolve such a dispute or difference by mutual consultation, then the dispute shall be referred in writing by either party to the Adjudicator, with a copy to the other party.
- 6.1.2 The Adjudicator shall give its decision in writing to both parties within twenty-eight (28) days of a dispute being referred to it. If the Adjudicator has done so, and no notice of intention to commence arbitration has been given by either the EESL or the Implementing Partner within fifty-six (56) days of such reference, the decision shall become final and binding upon the EESL and the Implementing Partner. Any decision that has become final and binding shall be implemented by the parties forthwith.

6.1.3 Should the Adjudicator resign or die, or should the EESL and the Implementing Partner agree that the Adjudicator is not fulfilling its functions in accordance with the provisions of the Contract; another retired Judge of High Court/Supreme Court of India shall be jointly appointed by the EESL and the Implementing Partner as adjudicator under the Contract. Failing agreement between the two within twenty eight (28) days, the new retired judge of High Court/Supreme Court of India shall be appointed as the Adjudicator under the Contract at the request of either party by the Appointing Authority specified in the SCC. The adjudicator shall be paid fee plus reasonable expenditures incurred in the execution of its duties as adjudicator under the contract. This cost shall be divided equally between the EESL and the Implementing Partner.

6.2 Arbitration

- 6.2.1** If either the EESL or the Implementing Partner is dissatisfied with the Adjudicator's decision, or if the Adjudicator fails to give a decision within twenty-eight (28) days of a dispute being referred to it, then either the EESL or the Implementing Partner may, within fifty-six (56) days of such reference, give notice to the other party, with a copy for information to the Adjudicator, of its intention to commence arbitration, as hereinafter provided, as to the matter in dispute, and no arbitration in respect of this matter may be commenced unless such notice is given.
- 6.2.2** Any dispute in respect of which a notice of intention to commence arbitration has been given, in accordance with GCC Sub-Clause 6.2.1, shall be finally settled by arbitration. Arbitration may be commenced prior to or after completion of the Facilities.

In case the Contractor is a Public Sector Enterprise or a Government Department

6.2.3 In case the Contractor is a Public Sector Enterprise or a Government Department, the dispute shall be referred for resolution in Permanent Machinery for Arbitration (PMA) of the Department of Public Enterprise, Government of India. Such dispute or difference shall be referred by either party for Arbitration to the sole Arbitrator in the Department of Public Enterprises to be nominated by the Secretary to the Government of India in-charge of the Department of Public Enterprises. The award of the Arbitrator shall be binding upon the parties to the dispute, provided, however, any party aggrieved by such award may make a further reference for setting aside or revision of the award to the Law Secretary, Department of Legal Affairs, Ministry of Law & Justice, Government of India. Upon such reference the dispute shall be decided by the Law Secretary or the Special Secretary/Additional Secretary, when so authorized by the Law Secretary, whose decision shall bind the Parties finally and conclusively. The Parties to the dispute will share equally the cost of arbitration as intimated by the Arbitrator.

In case the Contractor is not a Public Sector Enterprise or a Government Department

Any dispute or differences arising out of or touching this Agreement if not resolved amicably within 30 days of raising such dispute or difference and subject to cure period as provided in the Agreement; shall be referred to the Arbitration, of single arbitrator mutually agreed between the Parties. In case the parties fail to agree upon single arbitrator then, either of the party may approach a competent court for the appointment of the arbitrator in accordance with the provisions of the Arbitration and Conciliation Act, 1996 and any and all amendment thereunder. The decision of the arbitral tribunal shall be final and binding on the Parties.

The arbitration proceedings shall be conducted in accordance with the provisions of the Arbitration & Conciliation Act, 1996 and any and all amendment thereunder. The language of arbitration shall be English, cost of arbitration shall be borne equally by the Parties and the venue of arbitration shall be Delhi, India.

Notwithstanding any reference to the Adjudicator or Arbitration herein,

Parties shall continue to perform their respective obligations under the Contract, except for the matter under dispute pursuant to Arbitration proceedings

2. Subject Matter of Contract

6.3 Scope of Facilities

6.3.1 Unless otherwise expressly limited in the Technical Specifications, the Implementing Partner's obligations cover the provision of all Plant and Equipment and the performance of all Installation Services required for the design, the manufacture (including procurement, quality assurance, construction, installation, associated civil works, Recommissioning and delivery) of the Plant and Equipment and the installation, completion, commissioning and performance testing of the Facilities in accordance with the plans, procedures, specifications, drawings, codes and any other documents as specified in the Technical Specifications. Such specifications include, but are not limited to, the provision of supervision and engineering services; the supply of labour, materials, equipment, spare parts (as specified in GCC Sub-Clause 7.3 below) and accessories; Implementing Partner's Equipment; construction utilities and supplies; temporary materials, structures and facilities; transportation (including, without limitation, unloading and hauling to, from and at the Site); and storage, except for those supplies, works and services that will be provided or performed by the EESL, as set forth in Appendix 6 (Scope of Works and Supply by the EESL) to the Contract Agreement.

7.2 The Contractor or Implementing Partner shall, unless specifically excluded in the Contract, perform all such work and/or supply all such items and materials not specifically mentioned in the Contract but that can be reasonably inferred from the Contract as being required for attaining Completion of the Facilities as if such work and/or items and materials were expressly mentioned in the Contract.

7.3 In addition to the supply of Mandatory Spare Parts if asked and warranty spares included in the Contract, the Implementing Partner agrees to supply spare parts required for the operation and maintenance of the Facilities. However, the identity, specifications and quantities of such spare parts and the terms and conditions relating to the supply thereof are to be agreed between the EESL and the Implementing Partner, and the price of such if asked spare parts shall be that given in Price Schedule which shall be added to the Contract Price. The price of such spare parts shall include the purchase price there for and other costs and expenses (including the Implementing Partner's fees) relating to the supply of spare parts. The prices of spares covered under the Price Schedule shall be kept valid for a period as specified in SCC.

7.3.1 The Contractor / Implementing Partner agrees that the spare parts recommended by him for 3 years operation and quoted in price Schedule shall be supplied by him at the same terms and conditions as are otherwise applicable to this Contract. Further, the Implementing Partner also agrees to supply spare parts required for the operation and maintenance of the Facilities as per provision of subsequent paragraphs of this Sub-Clause.

7.3.1.1 All the spares for the equipment under the Contract will strictly conform to the Specification and other relevant documents and will be identical to the corresponding main equipment/components supplied under the Contract and shall be fully interchangeable.

7.3.1.2 All the mandatory spares covered under the Contract shall be produced along with the main equipment as a continuous operation and the delivery of the spares will be effected along with the main equipment in a phased manner and the delivery would be completed by the respective dates for the various categories of equipment as per the agreed network. In case of recommended spares the above will be applicable provided the orders for the recommended spares have been placed with the Implementing Partner prior to commencement of manufacture of the main equipment.

7.3.1.3 The Implementing Partner will provide the EESL with the manufacturing drawings, catalogues, assembly drawings and any other document required by the EESL so as to enable the EESL to identify the recommended spares. Such details will be furnished to the EESL as soon as they are prepared but in any case not later than six months prior to commencement of manufacture of the corresponding main equipment.

7.3.1.4 To enable the EESL to finalise the requirement of recommended spares which are ordered subsequent to placement of order for main equipment/plant, in addition to necessary technical details,

catalogue and such other information brought-out herein above, the Implementing Partner will also provide a justification in support of reasonableness of the quoted prices of spares which will, inter-alia, include documentary evidence that the prices quoted by the Implementing Partner to the EESL are not higher than those charged by him from other customers in the same period.

7.3.1.5 In addition to the spares recommended by the Implementing Partner, if the EESL further identifies certain items of spares, the Implementing Partner will submit the prices and delivery quotation for such spares within thirty (30) days of receipt of such request with a validity period of six (6) months for consideration by the EESL and placement of order for additional spares if the EESL so desires.

7.3.1.6 The quality plan and the inspection requirement finalised for the main equipment will also be applicable to the corresponding spares.

7.3.1.7 The Contractor or Implementing Partner will provide the EESL with all the addresses and particulars of his sub-suppliers while placing the order on vendors for items/components/equipment covered under the Contract and will further ensure with his vendors that the EESL, if so desires, will have the right to place order for spares directly on them on mutually agreed terms based on offers of such vendors.

7.3.1.8 The Contractor or Implementing Partner shall guarantee the long term availability of spares to the EESL for the full life of the equipment covered under the Contract. The Implementing Partner shall guarantee that before going out of production of spare parts of the equipment covered under the Contract, he shall give the EESL at least 2 years advance notice so that the latter may order his bulk requirement of spares, if it so desires. The same provision will also be applicable to Sub-Implementing Partners. Further, in case of discontinuance of manufacture of any spares by the Contractor and/or his Sub- Contractor or Implementing Partner, Implementing Partner will provide the EESL, two years in advance, with full manufacturing drawings, material specification and technical information including information on alternative equivalent makes required by the EESL for the purpose of manufacture/procurement of such items.

7.3.1.9 The prices of all future requirements of item of spares beyond 3 years operational requirement will be derived from the corresponding ex-works price at which the order for such spares have been placed by EESL as a part of mandatory spares or recommended spares, or from the rates of mandatory spares or recommended spares as quoted by/ negotiated with the Implementing Partner. Ex-works order price of future spares shall be computed in accordance with the price adjustment provisions covered under the main Contract excepting that the base indices will be counted from the scheduled date of Commissioning of the last equipment under the main project and there will be no ceiling on the amount of variation in the prices. The above option for procuring future recommended spares by the EESL shall remain valid for the period of 5 years from the date of Commissioning of the equipment.

7.3.1.10 The Implementing Partner will indicate in advance the delivery period of the items of spares, which the EESL may procure in accordance with above sub-clause. In case of emergency requirements of spares, the Contractor would make every effort to expedite the manufacture and delivery of such spares on the basis of mutually agreed time schedule.

7.3.1.11 In case the Implementing Partner fails to supply the mandatory, recommended or long term spares in the terms stipulated above, the EESL shall be entitled to purchase the same from the alternate sources at the risk and the cost of the Implementing Partner and recover from the Implementing Partner, the excess amount paid by the EESL over the rates worked on the above basis. In the event of such risk purchase by the EESL, the purchases will be as per the Works and Procurement Policy of the EESL prevalent at the time of such purchases and the EESL at his option may include a representative from the Implementing Partner in finalising the purchases.

7.3.1.12 It is expressly understood that the final settlement between the par-ties in terms of relevant clauses of the Contract Documents shall not relieve the Implementing Partner of any of his obligations under the provision of long term availability of spares and such provisions shall continue to be enforced till the expiry of 5 years period reckoned from the scheduled date of Commissioning of the Plant and Equipment unless other-wise discharged expressly in writing by the EESL. Further, the provisions pertaining to long term availability of spares shall be extended beyond 5 years applicability period mentioned hereinabove if so desired by the EESL and at the mutually acceptable escalation formula.

7.3.1.13 The Implementing Partner shall warrant that all spares supplied will be new and in accordance with the Contract Documents and will be free from defects in design, material and workmanship and shall further guarantee as under:

- (i) For 3 years operational spares (both mandatory and recommended)
 - a) For any item of spares ordered or to be ordered by the EESL for 3 years operational requirement of the plant which are manufactured as a continuous operation together with the corresponding main equipment/component, the Defect Liability Period will be twelve (12) months from the scheduled date of commercial operation of main equipment/ plant under the Contract. 'Commercial Operation' shall mean the conditions of operation in which the complete equipment covered under the Contract is officially declared by the EESL to be available for continuous operation at different loads up to and including rated capacity. Such declaration by the EESL, however, shall not relieve or prejudice the Implementing Partner any of his obligations under the Contract. In case of any failure in the original component/equipment's due to faulty designs, materials and workmanship, the corresponding spare parts, if any, supplied will be replaced without any extra cost to the EESL unless a joint examination and analysis by the EESL and the Implementing Partner of such spare parts prove that the defect found in the original part that failed, can safely be assumed not to be present in spare parts. Such replaced spare parts will have the same Defect Liability as applicable to the replacement made for the defective original part/component provided that such replacement for the original equipment and the spare replaced are again manufactured together. The discarded spare parts will become the property of the Implementing Partner as soon as they have been replaced by the Implementing Partner.
 - b) For the item of spares ordered or to be ordered by the EESL for 3 years operational requirement of the plant, which with the written approval of the EESL, are not manufactured as a continuous operation will be warranted for 7000 hrs of trouble free operation if used within a period of eighteen (18) months reckoned from the date of delivery at site. However, if such spare parts are put to use after eighteen (18) months of the delivery at Site then the guarantee of such spares will stand valid till the expiry of thirty six (36) months from the scheduled date of Commissioning of equipment/plant covered under the contract or 7000 hrs of trouble free operation after such spares are put in service, whichever is earlier.
 - c) For long term requirement

For item of spares that may be ordered by the EESL to cover requirements beyond 3 years of Initial Operation of the plant, the warranty will be till the expiry of 7000 hrs of trouble free operation if used within a period of eighteen (18) months from the date of delivery at site. For item of spares that may be used after eighteen (18) months from the date of delivery at site, the warranty period will be 12 months from the date they are put to use or 7000 hrs of trouble free operation, whichever is earlier. In any case the defectliability of spares will expire at the end of forty eight (48) months from the date of theirreceipt at site.

- (ii) The Defect Liability of spares covered in para (b) & (c) above, that are not used within 18 months from the respective date of the delivery at Site will, however, be subject to condition that all such spares being stored/maintained/preserved in accordance with Implementing Partner's standard recommended practice, if any, and the same has been furnished to the EESL.

6.4 *Time for Commencement and Completion*

6.4.1 The Implementing Partner shall commence work on the Facilities from the date of Notification of Award and without prejudice to GCC Sub-Clause 26.2 hereof, the Implementing Partner shall thereafter proceed with the Facilities in accordance with the time schedule specified in Appendix 4 (Time Schedule) to the Contract Agreement or / and as mentioned in special conditions of contract.

6.4.2 The Implementing Partner shall attain Completion of the Facilities (or of a part where a separate time for Completion of such part is specified in the Contract) within the time stated in the SCC or within such extended time to which the Implementing Partner shall be entitled under GCC Clause 40 (Extension of Time for Completion) hereof.

6.5 *Contractor or Implementing Partner's Responsibilities*

6.5.1 The Contractor or Implementing Partner shall design, manufacture (including associated purchases and/or subcontracting), install and complete the Facilities with due care and diligence in accordance with the Contract.

6.5.2 The Contractor or Implementing Partner confirms that it has entered into this Contract on the basis of a proper examination of the data relating to the Facilities (including any data as to boring tests if applicable) provided by the EESL, and on the basis of information that the Contractor or Implementing Partner could have obtained from a visual inspection of the Site (if access thereto was available) and of other data readily available to it relating to the Facilities as at the date twenty-eight (28) days prior to bid submission. The Implementing Partner acknowledges that any failure to acquaint itself with all such data and information shall not relieve its responsibility for properly estimating the difficulty or cost of successfully performing the Facilities.

6.5.3 The Implementing Partner shall acquire in its name all permits, approvals and/or licenses from all local, state or national government authorities or public service undertakings in the country where the Site is located that are necessary for the performance of the Contract, including, without limitation, visas for the Contractor or Implementing Partner's and Sub Contractor or Implementing Partner's personnel and entry permits for all imported Implementing Partner's Equipment. The Implementing Partner shall acquire all other permits, approvals and/or licenses that are not the responsibility of the EESL under GCC Sub-Clause 10.3 hereof and that are necessary for the performance of the Contract.

6.5.4 The Implementing Partner shall comply with all laws in force in the country where the Facilities are installed and where the Installation Services are carried out. The laws will include all national, provincial, municipal or other laws that affect the performance of the Contract and bind upon the Implementing Partner. The Implementing Partner shall indemnify and hold harmless the EESL from and against any and all liabilities, damages, claims, fines, penalties and expenses of whatever nature arising or resulting from the violation of such laws by the Contractor or Implementing Partner or its personnel, including the Contractor or Sub Implementing Partners and their personnel, but without prejudice to GCC Sub Clause 10.1 hereof.

6.5.5 Any Plant, Material and Services that will be incorporated in or be required for the Facilities and other supplies shall have their origin as specified under GCC Clause 3.13 (Country of Origin).

6.6 *EESL's Responsibilities*

6.6.1 The EESL shall ensure the accuracy of all information and/or data to be supplied by the EESL as described in Appendix 6 (Scope of Works and Supply by the EESL) to the Contract, except when otherwise expressly stated in the Contract.

6.6.2 The EESL shall be responsible for acquiring and providing legal and physical possession of the Site and access thereto, and for providing possession of and access to all other areas reasonably required for the proper execution of the Contract, including all requisite rights of way, as specified in Appendix 6 (Scope of Works and Supply by the EESL) to the Contract Agreement. The EESL shall give full possession of and accord all rights of access thereto on or before the date(s) specified in Appendix 6.

6.6.3 The EESL shall acquire and pay for all permits, approvals and/or licenses from all local, state or national government authorities or public service undertakings in the country where the Site is located which such authorities or undertakings require the EESL to obtain them in the EESL's name, are necessary for the execution of the Contract (they include those required for the performance by both the Implementing Partner and the EESL of their respective obligations under the Contract), including those specified in Appendix 6 (Scope of Works and Supply by the EESL) to the Contract Agreement.

6.6.4 If requested by the Implementing Partner, the EESL shall use its best endeavours to assist the Implementing Partner in obtaining in a timely and expeditious manner all permits, approvals and/or licenses necessary for the execution of the Contract from all local, state or national government authorities or public service undertakings that such authorities or undertakings require the Contractor or Implementing Partner or Subcontractor or Implementing Partners or the personnel of the Contractor or Implementing Partner or Sub Contractor or Implementing Partners, as the case may be, to obtain.

6.6.5 Unless otherwise specified in the Contract or agreed upon by the EESL and the Implementing Partner, the EESL shall provide sufficient, properly qualified operating and maintenance personnel; shall supply and make available all raw materials, utilities, lubricants, chemicals, catalysts other materials and facilities; and shall perform all work and services of whatsoever nature, to enable the Implementing Partner to properly carry out Pre commissioning, Commissioning and Guarantee Tests, all in accordance with the provisions of Appendix 6 (Scope of Works and Supply by the EESL) to the Contract Agreement at or before the time specified in the program furnished by the Contractor or Implementing Partner under GCC Sub- Clause 18.2 (Program of Performance) hereof and in the manner there-upon specified or as otherwise agreed upon by the EESL and the Contractor or Implementing Partner.

6.6.6 The EESL shall be responsible for the continued operation of the Facilities after Completion, in accordance with GCC Sub-Clause 24.8, and shall be responsible for facilitating the Guarantee Test(s) for the Facilities, in accordance with GCC Sub-Clause 25.2.

6.6.7 All costs and expenses involved in the performance of the obligations under this GCC Clause 10 shall be the responsibility of the EESL save those to be incurred by the Implementing Partner with respect to the performance of Guarantee Tests, in accordance with GCC Sub-Clause 25.2.

e) *Payment*

6.7 **Contract Price**

6.7.1 The Contract Price shall be as specified in Article 2 (Contract Price and Terms of Payment) of the Form of Contract Agreement.

6.7.2 The Contract Price shall be adjusted in accordance with provisions of Appendix-2 (Price Adjustment) to the Contract Agreement, if applicable. It will be mentioned in SCC.

6.7.3 Subject to GCC Sub-Clauses 9.2, 10.1 and 35 (Unforeseen Conditions) hereof, the Implementing Partner shall be deemed to have satisfied itself as to the hereof, correctness and sufficiency of the Contract Price, which shall, except as otherwise provided for in the Contract, cover all its obligations under the Contract.

6.7.4 If the payment of any amount under this Agreement is disputed (by EESL), then the entire undisputed element of that amount shall be paid and the said disputed element shall be dealt with in accordance with the arbitration procedure set forth under the Agreement. EESL shall identify the specific cause of the disagreement.

6.8 *Terms of Payment*

6.8.1 The Contract price shall be paid as specified in Appendix 1 (Terms and Procedures of Payment) to the Contract Agreement. The procedures to be followed in making application for and processing payments shall be those outlined in the same Appendix 1.

6.8.2 No payment made by the EESL herein shall be deemed to constitute acceptance by the EESL of the Facilities or any part(s) thereof.

6.8.3 The currency or currencies in which payments are made to the Implementing Partner under this Contract shall be specified in Appendix 1 (Terms and Procedures of Payment) to the Contract Agreement, subject to the general principle that payments will be made in the currency or currencies in which the Contract Price has been stated in the Contract.

6.9 *Securities*

6.9.1 Issuance of Securities

The Implementing Partner shall provide the securities specified below in favour of the EESL at the times, and in the amount, manner and form specified below.

6.9.2 Advance Payment Security

6.9.2.1 The Implementing Partner shall, within twenty-eight (28) days of the notification of contract award, provide a security in an amount equal to the advance payment calculated in accordance with Appendix 1 (Terms and Procedures of Payment) to the Contract Agreement, and in the currency or currencies of the contract, with a initial validity of up to ninety (90) days beyond the schedule date of Completion of the Facilities in accordance with GCC Clause 24. However, in case of delay in completion of facilities under the package, the validity of the security shall be extended by the period of such delay.

6.9.2.2 The security shall be in the form of an unconditional bank guarantee as per the proforma provided in Section VII (Forms and Procedures)- Form of Advance Payment Security. The Advance payment Security shall be reduced prorate every three (3) months after First Running Account Bill/Stage Payment under the Contract based on the value of equipment/facilities received. The cumulative amount of reduction at any point of time shall not exceed seventy five percent (75%) of the advance corresponding to cumulative value of the respective equipment Facilities supplied and received as per a certificate issued by the Project Manager and the balance of 25% released after ninety (90) days beyond the Completion of those Facilities. It should be clearly understood that reduction in the value of security for advance shall not in any way dilute the Implementing Partner's responsibility and liabilities under the Contract including in respect of the Facilities for which the reduction in the value of security is allowed.

6.9.3 *Contract Performance Security*

6.9.3.1 The Implementing Partner shall, within twenty-eight (28) days of the Notification of Award, provide securities for the due performance of the Contract for 5% percent of Installation + 5% of maintenance for one year + 5% cost of IDC of all the Contracts, with an initial validity up to ninety (90) days beyond the end of scheduled Defect Liability Period of the last equipment covered under the package. If the EESL accepts to enters into 'Second Contract' and/or 'Third Contract' with the Assignee of a foreign Implementing Partner, pursuant to GCC Sub-Clause 3.6, the said Assignee, in addition to the Contract Performance Securities to be provided by the foreign Implementing Partner for five percent (5%) of the value of all the Contracts i.e. First Contract, Second Contract and Third Contract, shall provide within twenty eight (28) days of the Notification of Award, separate Contract Performance Security(ies) equivalent to five percent (5%) of the value of Contract(s) entered into with the Assignee, for the due performance of Contract, with a initial validity up to ninety (90) days beyond the end of Scheduled Defect Liability period of the last equipment covered under the package. However, in case of delay in completion of the defect liability period, the validity of all the contract performance securities shall be extended by the period of such delay. Further, EESL reserves the right to terminate the Contract at the risk and cost, as applicable, of the Contractor in case Contractor has not submitted the Contract Performance Guarantee within the stipulated timelines. This right of termination shall be without prejudice to EESL’s rights and remedies available in Contract or at law.

6.9.3.2 The performance security shall be denominated in the currency or currencies of the Contract, or in a freely convertible currency acceptable to the EESL, and shall be in the form of unconditional bank guarantee provided in Section-VII (Forms and Procedures)-Form of Performance Security of the bidding documents.

6.9.3.3 Unless otherwise stipulated in SCC, the security shall be reduced pro rata to the Contract Price of a part of the Facilities for which a separate time for Completion is provided, twenty one (21) months after Completion of the Facilities or where relevant part thereof, or fifteen (15) months after Operational

6.9.3.4 Acceptance of the Facilities (or the relevant part thereof), whichever occurs first; provided, however, that if the Defects Liability Period has been extended on any part of the Facilities pursuant to GCC Sub-Clause 27.8 hereof, the Implementing Partner shall issue an additional security in an amount proportionate to the Contract Price of that part. The security shall be returned to the Implementing Partner immediately after its expiration, provided, however, that if the Implementing Partner, pursuant to GCC Sub-Clause 27.10, is liable for an extended warranty obligation, the performance security shall be extended for the period and up to the amount agreed upon or as specified in the SCC.

6.10 Taxes and Duties

6.10.1 Except as otherwise specifically provided in the Contract, the Implementing Partner shall bear and pay all taxes, duties, levies and charges assessed on the Implementing Partner, its Sub-Implementing Partners or their employees by all municipal, state or national government authorities in connection with the Facilities in and outside of the country where the Site is located.

6.10.2 Notwithstanding GCC Sub-Clauses 14.1 above, the EESL shall bear and promptly reimburse all customs and import duties, if imposed in future, on the Plant and Equipment including Type Test and mandatory spares supplied from abroad and specified in Price Schedule (and on spare parts to be supplied from abroad and specified in Schedule, when awarded) and that are to be incorporated into the Facilities, by the law of the country where the Site is located. However, if the plant and equipment are shipped in Shipper's containers, then the custom duty levied on the cost of empty containers shall be borne and paid/reimbursed by the Implementing Partner. The EESL shall also bear and pay/reimburse to the Implementing Partner/ Assignee of Foreign Implementing Partner (if applicable) Sales Tax (but not the surcharge in lieu of Sales Tax), Local Tax including Entry Tax / Octroi (if applicable) in respect of direct transactions between the EESL and the Implementing Partner, if imposed on the Plant and Equipment including Type Test and Mandatory Spares manufactured within the EESL's country and specified in Price (and also on locally supplied spares quoted when awarded) to be incorporated in the Facilities, by the law of country where the site is located. For this purpose, the Ex-works price if quoted in foreign currency and so incorporated in the contract, shall be converted to Indian Rupees as per the TT buying exchange rates established by State Bank of India prevailing on the actual date of Ex-works (India) despatch.

All taxes, duties and levies on works contract, if any, shall be to the Implementing Partner's account and no separate claim in this regard will be entertained by the EESL.

6.10.3 If any tax exemptions, reductions, allowances or privileges is available to the Implementing Partner in the country where the Site is located, the EESL shall use its best endeavours to enable the Implementing Partner to benefit from any such tax savings to the maximum allowable extent.

6.10.4 For the purpose of the Contract, it is agreed that the Contract Price specified in Article 2 (Contract Price and Terms of Payment) of the Contract Agreement is based on the taxes, duties, levies and charges prevailing at the date seven (7) days prior to the last date of bid submission in the country where the Site is located (hereinafter called "Tax" in this GCC Sub-Clause 14.4). If any rates of Tax are increased or decreased, a new Tax is introduced, an existing Tax is abolished, or any change in interpretation or application of any Tax occurs in the course of the performance of Contract, which was or will be assessed on the Implementing Partner in connection with performance of the Contract, an equitable adjustment of the Contract Price shall be made to fully take into account any such change by addition to the Contract Price or deduction therefrom, as the case may be, in accordance with GCC Clause 36 (Change in Laws and Regulations) hereof. However, these adjustments would be restricted to direct transactions between the EESL and the Contractor/ assignee of Foreign Implementing Partner (if applicable). These adjustments shall not be applicable on procurement of raw materials, intermediary components etc. by the Implementing Partner/ assignee and also not applicable on the bought out items despatched directly from sub- vendor's works to site.

f) *Intellectual Property*

6.11 Copyright

6.11.1 The copyright in all drawings, documents and other materials containing data and information furnished to the EESL by the Implementing Partner herein shall remain vested in the Implementing Partner or, if they are furnished to the EESL directly or through the Implementing Partner by any third party, including suppliers of materials, the copyright in such materials shall remain vested in such third party. The EESL shall however be free to reproduce all drawings, documents and other material furnished to the EESL for the purpose of the contract including, if required, for operation and maintenance of the facilities.

6.12 Confidential Information

6.12.1 The EESL and the Implementing Partner shall keep confidential and shall not, without the written consent of the other party hereto, divulge to any third party any documents, data or other information furnished directly or indirectly by the other party hereto in connection with the Contract, whether such information has been furnished prior to, during or following termination of the Contract. Notwithstanding the above, the Contractor or Implementing Partner may furnish to its Sub-Contractor or Implementing Partner(s) such documents, data and other information it receives from the EESL to the extent required for the Sub Contractor or Implementing Partner(s) to perform its work under the Contract, in which event the Implementing Partner shall obtain from such Sub-Contractor or Implementing Partner(s) an undertaking of confidentiality similar to that imposed on the Implementing Partner under this GCC Clause 16.

6.12.2 The EESL shall not use such documents, data and other information received from the Implementing Partner for any purpose other than the operation and maintenance of the Facilities. Similarly, the Implementing Partner shall not use such documents, data and other information received from the EESL for any purpose other than the design, procurement of Plant and Equipment, construction or such other work and services as are required for the performance of the Contract.

6.12.3 The obligation of a party under GCC Sub-Clauses 16.1 and 16.2 above, however, shall not apply to that information which

- (a) now or hereafter enters the public domain through no fault of that party.
- (b) can be proven to have been possessed by that party at the time of disclosure and which was not previously obtained, directly or indirectly, from the other party hereto
- (c) Otherwise lawfully becomes available to that party from a third party that has no obligation of confidentiality.

6.12.4 The above provisions of this GCC Clause 16 shall not in any way modify any undertaking of confidentiality given by either of the parties hereto prior to the date of the Contract in respect of the Facilities or any part thereof.

6.12.5 The provisions of this GCC Clause 16 shall survive termination, for what-ever reason, of the Contract.

g) *Work Execution*

6.13 Representatives

6.13.1 Project Manager

If the Project Manager is not named in the Contract, then within fourteen (14) days of the Effective Date, the EESL shall appoint and notify the Implementing Partner in writing of the name of the Project Manager. The EESL may from time to time appoint some other person as the Project Manager in place of the person previously so appointed, and shall give a notice of the name of such other person to the Implementing Partner without delay. The EESL shall take reasonable care to see that no such appointment is made at such a time or in such a manner as to impede the progress of work on the Facilities. The Project Manager shall represent and act for the EESL at all times during the currency of the Contract. All notices, instructions, orders, certificates, approvals and all other communications under the Contract shall be given by the Project Manager, except as herein otherwise provided.

All notices, instructions, information and other communications given by the Implementing Partner to the EESL under the Contract shall be given to the Project Manager, except as herein otherwise provided.

6.13.2 Contractor's representative & Construction Manager

6.13.2.1 If the Implementing Partner's Representative is not named in the Contract, then within fourteen (14) days of the Effective Date, the Implementing Partner shall appoint the Implementing Partner's Representative and shall request the EESL in writing to approve the person so appointed. If the EESL makes no objection to the appointment within fourteen (14) days, the Implementing Partner's Representative shall be deemed to have been approved. If the EESL objects to the appointment within fourteen (14) days giving the reason therefor, then the Implementing Partner shall appoint a replacement within fourteen (14) days of such objection, and the foregoing provisions of this GCC Sub-Clause 17.2.1 shall apply thereto.

6.13.2.2 The Implementing Partner's Representative shall represent and act for the Implementing Partner at all times during the currency of the Contract and shall give to the Project Manager all the Implementing Partner's notices, instructions, information and all other communications under the Contract.

All notices, instructions, information and all other communications given by the EESL or the Project Manager to the Implementing Partner under the Contract shall be given to the Implementing Partner's Representative or, in its absence, its deputy, except as herein otherwise provided.

The Implementing Partner shall not revoke the appointment of the Implementing Partner's Representative without the EESL's prior written consent, which shall not be unreasonably withheld. If the EESL consents thereto, the Implementing Partner shall appoint some other person as the Implementing Partner's Representative, pursuant to the procedure set out in GCC Sub-Clause 17.2.1

6.13.2.3 The Implementing Partner’s Representative may, subject to the approval of the EESL (which shall not be unreasonably withheld), at any time delegate to any person any of the powers, functions and authorities vested in him or her. Any such delegation may be revoked at any time. Any such delegation or revocation shall be subject to a prior notice signed by the Implementing Partner’s Representative, and shall specify the powers, functions and authorities thereby delegated or revoked. No such delegation or revocation shall take effect unless and until a copy thereof has been delivered to the EESL and the Project Manager.

Any act or exercise by any person of powers, functions and authorities so delegated to him or her in accordance with this GCC Sub-Clause 17.2.3 shall be deemed to be an act or exercise by the Implementing Partner’s Representative.

6.13.2.3.1 Notwithstanding anything stated in GCC Sub-clause 17.1 and 17.2.1 above, for the purpose of execution of contract, the EESL and the Implementing Partner shall finalise and agree to a Contract Co-ordination Procedure and all the communication under the Contract shall be in accordance with such Contract Co-ordination Procedure.

6.13.2.4 From the commencement of installation of the Facilities at the Site until Operational Acceptance, the Implementing Partner’s Representative shall appoint a suitable person as the construction manager (hereinafter referred to as “the Construction Manager”). The Construction Manager shall supervise all work done at the Site by the Implementing Partner and shall be present at the Site throughout normal working hours except when on leave, sick or absent for reasons connected with the proper performance of the Contract. When-ever the Construction Manager is absent from the Site, a suitable person shall be appointed to act as his or her deputy.

6.13.2.5 The EESL may by notice to the Implementing Partner object to any representative or person employed by the Implementing Partner in the execution of the Contract who, in the reasonable opinion of the EESL, may behave inappropriately, may be incompetent or negligent, or may commit a serious breach of the Site regulations provided under GCC Sub-Clause 22.3. The EESL shall provide evidence of the same, whereupon the Implementing Partner shall remove such person from the Facilities.

6.13.2.6 If any representative or person employed by the Implementing Partner is removed in accordance with GCC Sub-Clause 17.2.5, the Contractor shall, where required, promptly appoint a replacement.

6.14 Work Program

6.14.1 Contractor or Implementing Partner’s Organization

The Implementing Partner shall supply to the EESL and the Project Manager a chart showing the proposed organization to be established by the Implementing Partner for carrying out work on the Facilities. The chart shall include the identities of the key personnel together with the curricula vitae of such key personnel to be employed within twenty-one (21) days of the Effective Date. The Implementing Partner shall promptly inform the EESL and the Project Manager in writing of any revision or alteration of such an organization chart.

6.14.2 Program of Performance

Within twenty-eight (28) days after the date of notification of award of Contract, the Implementing Partner shall prepare and submit to the Project Manager a detailed program of performance of the Contract, made in the form of PERT Network and showing the sequence in which it proposes to design, manufacture, transport, assemble, install and pre-commission the Facilities, as well as the date by which the Implementing Partner reasonably requires that the EESL shall have fulfilled its obligations under the Contract so as to enable the Implementing Partner to execute the Contract in accordance with the program and to achieve Completion and Acceptance of the Facilities in accordance with the Contract. The program so submitted by the Implementing Partner shall accord with the Time Schedule included in Appendix 4 (Time Schedule) to the Contract Agreement and any other dates and periods specified in the Contract. The Implementing Partner shall update and revise the program as and when appropriate or when required by the Project Manager, but without modification in the Times for Completion given in the SCC and any extension granted in accordance with GCC Clause 40, and shall submit all such revisions to the Project Manager.

6.14.3 Progress Report

The Contractor or Implementing Partner shall monitor progress of all the activities specified in the program referred to in GCC Sub-Clause 18.2 (Program of Performance) above, and supply a progress report to the Project Manager every month.

The progress report shall be in a form acceptable to the Project Manager and shall also indicate: (a) percentage completion achieved compared with the planned percentage completion for each activity; and (b) where any activity is behind the program, giving comments and likely consequences and stating the corrective action being taken.

6.14.4 Progress of Performance

If at any time the Implementing Partner's actual progress falls behind the program referred to in GCC Sub-Clause 18.2 (Program of Performance), or it becomes apparent that it will so fall behind, the Implementing Partner shall, at the request of the EESL or the Project Manager, prepare and submit to the Project Manager a revised program, taking into account the prevailing circumstances, and shall notify the Project Manager of the steps being taken to expedite progress so as to attain Completion of the Facilities within the Time for Completion under GCC Sub-Clause 8.2 (Time for Commencement and Completion), any extension thereof entitled under GCC Sub-Clause 40.1 (Extension of Time for Completion), or any extended period as may otherwise be agreed upon between the EESL and the Implementing Partner.

6.14.5 *Work Procedures*

The Contract shall be executed in accordance with the Contract Documents and the procedures given in the section on Forms and Procedures of the Contract Documents.

If agreed between the EESL and the Implementing Partner, the Implementing Partner may execute the Contract in accordance with its own standard project execution plans and procedures to the extent that they do not conflict with the provisions contained in the Contract.

6.14.6 *Maintenance of Records of Weekly Progress Review meeting at Site*

The Contractor shall be required to attend all weekly site progress review meetings organised by the 'Project Manager' or his authorised representative. The deliberations in the meetings shall interalia include the weekly program, progress of work (including details of manpower, tools & plants deployed by the Contractor vis-a-vis agreed schedule), inputs to be provided by Employer, delays, if any and recovery program, specific hindrances to work and work instructions by Employer. The minutes of the weekly meetings shall be recorded in triplicate in a numbered register available with the Project Manager or his authorised representative. These representative and the Contractor and one copy of the signed records shall be handed over to the Contractor.

6.15 *Subcontracting*

6.15.1 Appendix 5 (List of Approved Sub-Implementing Partners) to the Contract Agreement specifies major items of supply or services and a list of approved Sub-Implementing Partners against each item, including vendors. Insofar as no Sub-Implementing Partners are listed against any such item, the Implementing Partner shall prepare a list of Sub-Implementing Partners for such item for inclusion in such list. The Implementing Partner may from time to time propose any addition to or deletion from any such list. The Implementing Partner shall submit any such list or any modification thereto to the EESL for its approval in sufficient time so as not to impede the progress of work on the Facilities. Such approval by the EESL for any of the Sub-Implementing Partners shall not relieve the Implementing Partner from any of its obligations, duties or responsibilities under the Contract.

6.15.2 The Implementing Partner shall select and employ its Sub-Implementing Partners for such major items from those listed in the lists referred to in GCC Sub-Clause 19.1.

6.15.3 For items or parts of the Facilities not specified in Appendix 5 (List of Approved Sub-Implementing Partners) to the Contract Agreement, the Implementing Partner may employ such Sub-Implementing Partners as it may select, at its discretion.

6.16 *Design and Engineering*

6.16.1 Specifications and Drawings

6.16.1.1 The Implementing Partner shall execute the basic and detailed design and the engineering work in compliance with the provisions of the Contract, or where not so specified, in accordance with good engineering practice.

The Implementing Partner shall be responsible for any discrepancies, errors or omissions in the specifications, drawings and other technical documents that it has prepared, whether such specifications, drawings and other documents have been approved by the Project Manager or not, provided that such discrepancies, errors or omissions are not because of inaccurate information furnished in writing to the Implementing Partner by or on behalf of the EESL.

6.16.1.2 The Implementing Partner shall be entitled to disclaim responsibility for any design, data, drawing, specification or other document, or any modification thereof provided or designated by or on behalf of the EESL, by giving a notice of such disclaimer to the Project Manager.

6.16.2 Codes and Standards

Wherever references are made in the Contract to codes and standards in accordance with which the Contract shall be executed, the edition or the revised version of such codes and standards current at the date twenty-eight (28) days prior to date of bid submission shall apply unless otherwise specified. During Contract execution, any changes in such codes and standards shall be applied after approval by the EESL and shall be treated in accordance with GCC Clause 39 (Changes Originating from Implementing Partner).

6.16.3 Approval/Review of Technical Documents by Project Manager, where ever applicable

6.16.3.1 The Implementing Partner shall prepare (or cause its Sub-Implementing Partners to prepare) and furnish to the Project Manager the documents listed in Appendix 7 (List of Documents for Approval or Review) to the Contract Agreement for its approval or review as specified and as in accordance with the requirements of GCC Sub-Clause 18.2 (Program of Performance).

Any part of the Facilities covered by or related to the documents to be approved by the Project Manager shall be executed only after the Project Manager's approval thereof.

GCC Sub-Clauses 20.3.2 through 20.3.7 shall apply to those documents requiring the Project Manager's approval, but not to those furnished to the Project Manager for its review only.

6.16.3.2 Within twenty one (21) days after receipt by the Project Manager of any document requiring the Project Manager's approval in accordance with GCC Sub-Clause 20.3.1, the Project Manager shall either return one copy thereof to the Implementing Partner with its approval endorsed thereon or shall notify the Implementing Partner in writing of its disapproval thereof and the reasons therefor and the modifications that the Project Manager proposes.

6.16.3.3 The Project Manager shall not disapprove any document, except on the grounds that the document does not comply with some specified provision of the Contract or that it is contrary to good engineering practice.

6.16.3.4 If the Project Manager disapproves the document, the Implementing Partner shall modify the document and resubmit it for the Project Manager’s approval in accordance with GCC Sub-Clause

20.3.2. If the Project Manager approves the document subject to modification(s), the Implementing Partner shall make the required modification(s), and upon resubmission with the required modifications the document shall be deemed to have been approved.

The procedure for submission of the documents by the Implementing Partner and their approval by the Project Manager shall be discussed and finalised with the Implementing Partner.

6.16.3.5 If any dispute or difference occurs between the EESL and the Implementing Partner in connection with or arising out of the disapproval by the Project Manager of any document and/or any modification(s) thereto that cannot be settled between the parties within a reasonable period, then such dispute or difference may be referred to an Adjudicator for determination in accordance with GCC Sub-Clause 6.1 (Adjudicator) hereof. If such dispute or difference is referred to an Adjudicator, the Project Manager shall give instructions as to whether and if so, how, performance of the Contract is to proceed. The Implementing Partner shall proceed with the Contract in accordance with the Project Manager’s instructions, provided that if the Adjudicator upholds the Implementing Partner’s view on the dispute and if the EESL has not given notice under GCC Sub-Clause 6.1.2 hereof, then the Implementing Partner shall be reimbursed by the EESL for any additional costs incurred by reason of such instructions and shall be relieved of such responsibility or liability in connection with the dispute and the execution of the instructions as the Adjudicator shall decide, and the Time for Completion shall be extended accordingly.

6.16.3.6 The Project Manager’s approval, with or without modification of the document furnished by the Implementing Partner, shall not relieve the Implementing Partner of any responsibility or liability imposed upon it by any provisions of the Contract except to the extent that any subsequent failure results from modifications required by the Project Manager.

6.16.3.7 The Implementing Partner shall not depart from any approved document unless the Implementing Partner has first submitted to the Project Manager an amended document and obtained the Project Manager’s approval thereof, pursuant to the provisions of this GCC Sub-Clause 20.3.

If the Project Manager requests any change in any already approved document and/or in any document based thereon, the provisions of GCC Clause 39 (Change in the Facilities) shall apply to such request.

6.17 Procurement

6.17.1 Plant and Equipment

Subject to GCC Sub-Clause 14.2, the Implementing Partner shall manufacture or procure and transport all the Plant and Equipment in an expeditious and orderly manner to the Site.

NIT/Bid Document No.: EESL/06/24-25/SERC-Contracts/TS/CCMS - GHMC & ULB/OTE-232414, Date: 25/09/2024	SECTION – 3 GCC	Page 26 of 61
--	--------------------	---------------

6.17.2 *EESL-Supplied Plant, Equipment, and Materials*

If Appendix 6 (Scope of Works and Supply by the EESL) to the Contract Agreement provides that the EESL shall furnish any specific items of machinery, equipment or materials to the Implementing Partner, the following provisions shall apply:

6.17.2.1 The EESL shall, at its own risk and expense, transport each item to the place on or near the Site as agreed upon by the parties and make such item available to the Implementing Partner at the time specified in the program furnished by the Implementing Partner, pursuant to GCC Sub- Clause 18.2 (Program of Performance), unless otherwise mutually agreed.

6.17.2.2 Upon receipt of such item, the Implementing Partner shall inspect the same visually and notify the Project Manager of any detected shortage, defect or default. The EESL shall immediately remedy any shortage, defect or default, or the Implementing Partner shall, if practicable and possible, at the request of the EESL, remedy such shortage, defect or default at the EESL's cost and expense. After inspection, such item shall fall under the care, custody and control of the Implementing Partner. The provision of this GCC Sub-Clause 21.2.2 shall apply to any item supplied to remedy any such shortage or default or to substitute for any defective item, or shall apply to defective items that have been repaired.

6.17.2.3 The foregoing responsibilities of the Implementing Partner and its obligations of care, custody and control shall not relieve the EESL of liability for any undetected shortage, defect or default, nor place the Implementing Partner under any liability for any such shortage, defect or default whether under GCC Clause 27 (Defect Liability) or under any other provision of Contract.

6.17.3 *Transportation*

6.17.3.1 The Implementing Partner shall at its own risk and expense transport all the Plant and Equipment and the Implementing Partner's Equipment to the Site by the mode of transport that the Implementing Partner judges most suitable under all the circumstances.

Packing Material

The Contractor shall ensure that all the plant and equipment are suitably packed and protected to prevent damage or deterioration during its transportation to site, handling and storage at site till the time of its installation. The ownership of all such packing material (except empty shipper's containers on which the customs duty has been paid by the Contractor) shall stand transferred to the Employer upon dispatch of the plant and equipment and endorsement of dispatch documents in favour of the Employer.

6.17.3.2 Unless otherwise provided in the Contract, the Implementing Partner shall be entitled to select any safe mode of transport operated by any person to carry the Plant and Equipment and the Implementing Partner's Equipment.

6.17.3.3 Upon despatch of each shipment of the Plant and Equipment and the Implementing Partner's Equipment, the Implementing Partner shall notify the EESL by telex, cable, facsimile or Electronic Data Interchange (EDI) of the description of the Plant and Equipment and of the Implementing Partner's Equipment, the point and means of dispatch, and the estimated time and point of arrival in the country where the Site is located, if applicable, and at the Site. The Implementing Partner shall furnish the EESL with relevant shipping documents to be agreed upon between the parties.

6.17.3.4 The Implementing Partner shall be responsible for obtaining, if necessary, approvals from the authorities for transportation of the Plant and Equipment and the Implementing Partner's Equipment to the Site. The EESL shall use its best endeavours in a timely and expeditious manner to assist the Implementing Partner in obtaining such approvals, if requested by the Implementing Partner. The Implementing Partner shall indemnify and hold harmless the EESL from and against any claim for damage to roads, bridges or any other traffic facilities that may be caused by the transport of the Plant and Equipment and the Implementing Partner's Equipment to the Site.

6.17.4 Customs Clearance

The Implementing Partner shall, at its own expense, handle all imported Plant and Equipment and Implementing Partner's Equipment at the point(s) of import and shall handle any formalities for customs clearance, subject to the EESL's obligations under GCC Sub-Clause 14.2, provided that if applicable laws or regulations require any application or act to be made by or in the name of the EESL, the EESL shall take all necessary steps to comply with such laws or regulations. In the event of delays in customs clearance due to fault of the EESL, the Implementing Partner shall be entitled to an extension in the Time for Completion, pursuant to GCC Clause 40.

6.18 Installation

6.18.1 Setting Out/Supervision/Labour

6.18.1.1 Bench Mark: The Implementing Partner shall be responsible for the true and proper setting-out of the Facilities in relation to bench marks, reference marks and lines provided to it in writing by or on behalf of the EESL.

If, at any time during the progress of installation of the Facilities, any error shall appear in the position, level or alignment of the Facilities, the Implementing Partner shall forthwith notify the Project Manager of such error and, at its own expense, immediately rectify such error to the reasonable satisfaction of the Project Manager. If such error is based on incorrect data provided in writing by or on behalf of the EESL, the expense of rectifying the same shall be borne by the EESL.

6.18.1.2 Implementing Partner's Supervision: The Implementing Partner shall give or provide all necessary superintendence during the installation of the Facilities, and the Construction Manager or its deputy shall be constantly on the Site to provide full-time superintendence of the installation.

The Implementing Partner shall provide and employ only technical personnel who are skilled and experienced in their respective callings and supervisory staff who are competent to adequately supervise the work at hand.

6.18.1.3 Labour:

- (a) The Implementing Partner shall provide and employ on the Site in the installation of the Facilities such skilled, semi-skilled and unskilled labour as is necessary for the proper and timely execution of the Contract. The Implementing Partner is encouraged to use local labour that has the necessary skills.
- (b) Unless otherwise provided in the Contract, the Implementing Partner shall be responsible for the recruitment, transportation, accommodation and catering of all labour, local or expatriate, required for the execution of the Contract and for all payments in connection therewith.
- (c) The Implementing Partner shall be responsible for obtaining all necessary permit(s) and/or visa(s) from the appropriate authorities for the entry of all labour and personnel to be employed on the Site into the country where the Site is located.
- (d) The Implementing Partner shall at its own expense provide the means of repatriation to all of its and its Sub Implementing Partner's personnel employed on the Contract at the Site to their various home countries. It shall also provide suitable temporary maintenance of all such persons from the cessation of their employment on the Contract to the date programmed for their departure. In the event that the Implementing Partner defaults in providing such means of transportation and temporary maintenance, the EESL may provide the same to such personnel and recover the cost of doing so from the Implementing Partner.
- (e) The Implementing Partner shall at all times during the progress of the Contract use its best endeavours to prevent any unlawful, riotous or disorderly conduct or behaviour by or amongst its employees and the labour of its Sub Implementing Partners.
- (f) The Implementing Partner shall, in all dealings with its labour and the labour of its Sub-Implementing Partners currently employed on or connected with the Contract, pay due regard to all recognized festivals, official holidays, religious or other customs and all local laws and regulations pertaining to the employment of labour.

6.18.2 Contractor's Implementing Partner's Equipment

6.18.2.1 All Contractors or Implementing Partners' Equipment brought by the Implementing Partner onto the Site shall be deemed to be intended to be used exclusively for the execution of the Contract. The Implementing Partner shall not remove the same from the Site without the Project Manager's consent that such Implementing Partner's Equipment is no longer required for the execution of the Contract.

6.18.2.2 Unless otherwise specified in the Contract, upon completion of the Facilities, the

NIT/Bid Document No.: EESL/06/24-25/SERC-Contracts/TS/CCMS - GHMC & ULB/OTE-232414, Date: 25/09/2024	SECTION – 3 GCC	Page 29 of 61
---	--------------------	---------------

Implementing Partner shall remove from the Site all Equipment brought by the Implementing Partner onto the Site and any surplus materials remaining thereon.

6.18.2.3 The EESL will, if requested, use its best endeavours to assist the Implementing Partner in obtaining any local, state or national government permission required by the Implementing Partner for the export of the Implementing Partner's Equipment imported by the Implementing Partner for use in the execution of the Contract that is no longer required for the execution of the Contract.

6.18.3 Site Regulations and Safety

The EESL and the Implementing Partner shall establish Site regulations setting out the rules to be observed in the execution of the Contract at the Site and shall comply therewith. The Implementing Partner shall prepare and submit to the EESL, with a copy to the Project Manager, proposed Site regulations for the EESL's approval, which approval shall not be unreasonably withheld.

Such Site regulations shall include, but shall not be limited to, rules in respect of security, safety of the Facilities, gate control, sanitation, medical care, and fire prevention.

6.18.4 Opportunities for Other Implementing Partners

6.18.4.1 The Implementing Partner shall, upon written request from the EESL or the Project Manager, give all reasonable opportunities for carrying out the work to any other Implementing Partners employed by the EESL on or near the Site.

6.18.4.2 If the Implementing Partner, upon written request from the EESL or the Project Manager, makes available to other Implementing Partners any roads or ways the maintenance for which the Implementing Partner is responsible, permits the use by such other Implementing Partners of the Implementing Partner's Equipment, or provides any other service of whatsoever nature for such other Implementing Partners, the EESL shall fully compensate the Implementing Partner for any loss or damage caused or occasioned by such other Implementing Partners in respect of any such use or service, and shall pay to the Implementing Partner reasonable remuneration for the use of such equipment or the provision of such services.

6.18.4.3 The Implementing Partner shall also so arrange to perform its work as to minimize, to the extent possible, interference with the work of other Implementing Partners. The Project Managers shall determine the resolution of any difference or conflict that may arise between the Implementing Partner and other Implementing Partners and the workers of the EESL in regard to their work.

6.18.4.4 The Implementing Partner shall notify the Project Manager promptly of any defects in the other Implementing Partners' work that come to its notice, and that could affect the Implementing Partner's work. The Project Manager shall determine the corrective measures, if any, required to rectify the situation after inspection of the Facilities. Decisions made by the Project Manager shall be binding on the Implementing Partner.

6.18.5 Emergency Work

If, by reason of an emergency arising in connection with and during the execution of the Contract, any protective or remedial work is necessary as a matter of urgency to prevent damage to the Facilities, the Implementing Partner shall immediately carry out such work.

If the Implementing Partner is unable or unwilling to do such work immediately, the EESL may cause such work to be done as the EESL may determine is necessary in order to prevent damage to the Facilities. In such event the EESL shall, as soon as practicable after the occurrence of any such emergency, notify the Implementing Partner in writing of such emergency, the work done and the reasons therefor. If the work done or caused to be done by the EESL is work that the Implementing Partner was liable to do at its own expense under the Contract, the reasonable costs incurred by the EESL in connection therewith shall be paid by the Implementing Partner to the EESL. Otherwise, the cost of such remedial work shall be borne by the EESL.

6.18.6 Site Clearance

6.18.6.1 Site Clearance in Course of Performance: In the course of carrying out the Contract, the Implementing Partner shall keep the Site reasonably free from all unnecessary obstruction, store or remove any surplus materials, clear away any wreckage, rubbish or temporary works from the Site, and remove any Implementing Partner's Equipment no longer required for execution of the Contract.

6.18.6.2 Clearance of Site after Completion: After Completion of all parts of the Facilities, the Implementing Partner shall clear away and remove all wreckage, rubbish and debris of any kind from the Site, and shall leave the Site and Facilities clean and safe.

Disposal of Scrap

The Contractor shall with the agreement of the Employer promptly remove from the site any 'Scrap' generated during performance of any activities at site in pursuance of the Contract. The term 'Scrap' shall refer to scrap / waste / remnants arising out of the fabrication of structural steel work and piping work at the project site in the course of execution of the contract and shall also include any wastage of cables during the termination process while installing the cables.

The ownership of such Scrap shall vest with the Contractor except in cases where the items have been issued by the Employer from its stores for their installation only without any adjustment to the Contract Price. The removal of scrap shall be subject to the Contractor producing the necessary clearance from the relevant authorities (Custom, Excise etc.), if required by the law, in respect of disposal of the scrap. The liability for the payment of the applicable taxes/duties shall be that of the Contractor. Harmful scrap shall be disposed as per environmental statutory or other guidelines at contractor or implementing partner own cost.

The Contractor shall also indemnify to keep the Employer harmless from any act of omission or negligence on the part of the Contractor in following the statutory requirements with regard to removal/disposal of scrap. The Indemnity Bond shall be furnished by Contractor as per proforma enclosed in Section-VII (Forms and Procedure) as Form No. 14. Further, in case the laws require the Employer to take prior permission of the relevant Authorities before handing over the scrap to the Contractor, the same shall be obtained by the Contractor on behalf of the Employer.

However, scrap generated in say replacement of pumps (i.e. old pumps as scrap) or any other scrap which is owned by EESL as per contract agreement, the same shall be disposed by EESL and EESL will get the payment. Contractor or Implementing Partner will co-ordinate with EESL and the agency picking up the scrap, for scrap disposal.

6.18.7 Watching and Lighting

The Implementing Partner shall provide and maintain at its own expense all lighting, fencing, and watching when and where necessary for the proper execution and the protection of the Facilities, or for the safety of the owners and occupiers of adjacent property and for the safety of the public.

6.18.8 Work at Night and on Holidays

6.18.8.1 Unless otherwise provided in the Contract, no work shall be carried out during the night and on public holidays of the country where the Site is located without prior written consent of the EESL, except where work is necessary or required to ensure safety of the Facilities or for the protection of life, or to prevent loss or damage to property, when the Implementing Partner shall immediately advise the Project Manager, provided that provisions of this GCC Sub-Clause 22.8.1 shall not apply to any work which is customarily carried out by rotary or double-shifts.

6.18.8.2 Notwithstanding GCC Sub-Clauses 22.8.1 or 22.1.3, if and when the Implementing Partner considers it necessary to carry out work at night or on public holidays so as to meet the Time for Completion and requests the EESL's consent thereto, the EESL shall not unreasonably withhold such consent.

6.19 Test and Inspection

6.19.1 The Implementing Partner shall at its own expense carry out at the place of manufacture and/or on the Site all such tests and/or inspections of the Plant and Equipment and any part of the Facilities as are specified in the Contract.

6.19.2 The EESL and the Project Manager or their designated representatives shall be entitled to attend the aforesaid test and/or inspection, provided that the EESL shall bear all costs and expenses incurred in connection with such attendance including, but not limited to, all traveling and board and lodging expenses.

6.19.3 Whenever the Implementing Partner is ready to carry out any such test and/or inspection, the Implementing Partner shall give a reasonable advance notice of such test and/or inspection and of the place and time thereof to the Project Manager. The Implementing Partner shall obtain from any relevant third party or manufacturer any necessary permission or consent to enable the EESL and the Project Manager (or their designated representatives) to attend the test and/or inspection

6.19.4 The Implementing Partner shall provide the Project Manager with a certified report of the results of any such test and/or inspection.

If the EESL or Project Manager (or their designated representatives) fails to attend the test and/or inspection, or if it is agreed between the parties that such persons shall not do so, then the Implementing Partner may proceed with the test and/or inspection in the absence of such persons, and may provide the Project Manager with a certified report of the results thereof.

6.19.5 The Project Manager may require the Implementing Partner to carry out any test and/or inspection not required by the Contract, provided that the Implementing Partner's reasonable costs and expenses incurred in the carrying out of such test and/or inspection shall be added to the Contract Price. Further, if such test and/or inspection impedes the progress of work on the Facilities and/or the Implementing Partner's performance of its other obligations under the Contract, due allowance will be made in respect of the Time for Completion and the other obligations so affected.

6.19.6 If any Plant and Equipment or any part of the Facilities fails to pass any test and/or inspection, the Implementing Partner shall either rectify or replace such Plant and Equipment or part of the Facilities and shall repeat the test and/or inspection upon giving a notice under GCC Sub-Clause 23.3.

6.19.7 If any dispute or difference of opinion shall arise between the parties in connection with or arising out of the test and/or inspection of the Plant and Equipment or part of the Facilities that cannot be settled between the parties within a reasonable period of time, it may be referred to the Adjudicator for determination in accordance with GCC Sub-Clause 6.1 (Adjudicator).

6.19.8 The Implementing Partner shall afford the EESL and the Project Manager, at the EESL's expense, access at any reasonable time to any place where the Plant and Equipment are being manufactured or the Facilities are being installed, in order to inspect the progress and the manner of manufacture or installation, provided that the Project Manager shall give the Implementing Partner a reasonable prior notice.

6.19.9 The Implementing Partner agrees that neither the execution of a test and/or inspection of Plant and Equipment or any part of the Facilities, nor the attendance by the EESL or the Project Manager, nor the issue of any test certificate pursuant to GCC Sub-Clause 23.4, shall release the Implementing Partner from any other responsibilities under the Contract.

6.19.10 No part of the Facilities or foundations shall be covered up on the Site without the Implementing Partner carrying out any test and/or inspection required under the Contract. The Implementing Partner shall give a reasonable notice to the Project Manager whenever any such part of the Facilities or foundations are ready or about to be ready for test and/or inspection; such test and/or inspection and notice thereof shall be subject to the requirements of the Contract.

6.19.11 The Implementing Partner shall uncover any part of the Facilities or foundations, or shall make openings in or through the same as the Project Manager may from time to time require at the Site, and shall reinstate and make good such part or parts.

If any part of the Facilities or foundations have been covered up at the Site after compliance with the requirement of GCC Sub-Clause 23.10 and are found to be executed in accordance with the Contract, the expenses of uncovering, making openings in or through, reinstating, and making good the same shall be borne by the EESL, and the Time for Completion shall be reasonably adjusted to the extent that the Implementing Partner has thereby been delayed or impeded in the performance of any of its obligations under the Contract.

6.20 Completion of the Facilities

6.20.1 As soon as the Facilities or any part thereof has, in the opinion of the Implementing Partner, been completed operationally and structurally and put in a tight and clean condition as specified in the Technical Specifications, excluding minor items not materially affecting the operation or safety of the Facilities, the Implementing Partner shall so notify the EESL in writing.

6.20.2 Within seven (7) days after receipt of the notice from the Implementing Partner under GCC Sub-Clause 24.1, the EESL shall supply the operating and maintenance personnel specified in Appendix 6 (Scope of Works and Supply by the EESL) to the Contract Agreement, required for Pre-commissioning of the Facilities or any part thereof.

Unless otherwise specified in the Technical Specifications, the EESL shall also provide, within the said seven (7) day period, the raw materials, utilities, lubricants, chemicals, catalysts, facilities, services and other matters required for Pre-commissioning of the Facilities or any part thereof.

6.20.3 As soon as reasonably practicable after the operating and maintenance personnel have been supplied by the EESL and the raw materials, utilities, lubricants, chemicals, catalysts, facilities, services and other matters, if so specified in Appendix 6 (Scope of Works and Supply by the EESL)/ Technical Specifications, have been provided by the EESL in accordance with GCC Sub-Clause 24.2, the Implementing Partner shall commence Pre-commissioning of the Facilities or the relevant part thereof in preparation for Commissioning.

6.20.4 As soon as all works in respect of Pre-commissioning are completed and, in the opinion of the Implementing Partner, the Facilities or any part thereof is ready for Commissioning, the Implementing Partner shall commence Commissioning as per procedures stipulated in Technical Specifications, and as soon as Commissioning is satisfactorily completed, the Implementing Partner shall so notify the Project Manager in writing.

6.20.5 The Project Manager shall, within fourteen (14) days after receipt of the Implementing Partner's notice under GCC Sub-Clause 24.4, either issue a Completion Certificate in the form specified in the Forms and Procedures section in the bidding documents, stating that the Facilities or that part thereof have reached Completion as at the date of the Implementing Partner's notice under GCC Sub- Clause 24.4, or notify the Implementing Partner in writing of any defects and/or deficiencies.

If the Project Manager notifies the Implementing Partner of any defects and/or deficiencies, the Implementing Partner shall then correct such defects and/or deficiencies, and shall repeat the procedure described in GCC Sub Clause 24.4.

If the Project Manager is satisfied that the Facilities or that part thereof have reached Completion, the Project Manager shall, within seven (7) days after receipt of the Implementing Partner's repeated notice, issue a Completion Certificate stating that the Facilities or that part thereof have reached Completion as at the date of the Implementing Partner's repeated notice.

If the Project Manager is not so satisfied, then it shall notify the Implementing Partner in writing of any defects and/or deficiencies within seven (7) days after receipt of the Implementing Partner's repeated notice, and the above procedure shall be repeated.

6.20.6 If the Project Manager fails to issue the Completion Certificate and fails to inform the Implementing Partner of any defects and/or deficiencies within fourteen (14) days after receipt of the Implementing Partner's notice under GCC Sub-Clause 24.4 or within seven (7) days after receipt of the Implementing Partner's repeated notice under GCC Sub-Clause 24.5, or if the EESL makes use of the Facilities or part thereof, then the Facilities or that part thereof shall be deemed to have reached Completion as of the date of the Implementing Partner's notice or repeated notice, or as of the EESL's use of the Facilities, as the case may be.

6.20.7 As soon as possible after Completion, the Implementing Partner shall complete all outstanding minor items so that the Facilities are fully in accordance with the requirements of the Contract, failing which the EESL will undertake such completion and deduct the costs thereof from any monies owing to the Implementing Partner.

6.20.8 Upon Completion, the EESL shall be responsible for the care and custody of the Facilities or the relevant part thereof, together with the risk of loss or damage thereto, and shall thereafter take over the Facilities or the relevant part thereof.

6.21 Commissioning, Guarantee Test and Operational Acceptance

6.21.1 Commissioning

NIT/Bid Document No.: EESL/06/24-25/SERC-Contracts/TS/CCMS - GHMC & ULB/OTE-232414, Date: 25/09/2024	SECTION – 3 GCC	Page 35 of 61
--	--------------------	---------------

6.21.1.1 Commissioning of the Facilities or any part thereof shall be completed by the Implementing Partner as per procedures detailed in the Technical Specifications.

The EESL shall, unless otherwise specified in Appendix 6(Scope of Works and Supply by the EESL)/ Technical Specifications, supply the operating and maintenance personnel and all raw materials, utilities, lubricants, chemicals, catalysts, facilities, services and other matters required for Commissioning of the Facilities.

6.21.2 *Guarantee Test (where ever applicable)*

6.21.2.1 The Guarantee Test (and repeats thereof) shall be conducted by the Implementing Partner after Commissioning of the Facilities or the relevant part thereof to ascertain whether the Facilities or the relevant part can attain the Functional Guarantees specified in the Contract Documents. The Implementing Partner's and Project Manager's advisory personnel shall attend the Guarantee Test. The EESL shall promptly provide the Implementing Partner with such information as the Implementing Partner may reasonably require in relation to the conduct and results of the Guarantee Test (and any repeats thereof).

6.21.2.2 If for reasons not attributable to the Implementing Partner, the Guarantee Test of the Facilities or the relevant part thereof cannot be successfully completed within the period from the date of Completion specified in the SCC or any other period agreed upon by the EESL and the Implementing Partner, the Implementing Partner shall be deemed to have fulfilled its obligations with respect to the Functional Guarantees, and GCC Sub-Clauses 28.2 and 28.3 shall not apply.

6.21.3 *Operational Acceptance*

25.3.1 Subject to GCC Sub-Clause 25.4 (Partial Acceptance) below, Operational Acceptance shall occur in respect of the Facilities or any part thereof when

- (a) the Guarantee Test has been successfully completed and the Functional Guarantees are met; or
- (b) the Guarantee Test has not been successfully completed or has not been carried out for reasons not attributable to the Implementing Partner within the period from the date of Completion specified in the SCC or any other agreed upon period as specified in GCC Sub-Clause 25.2.2 above, but successful Completion of the Facilities has been achieved; or
- (C) the Implementing Partner has paid the liquidated damages specified in GCC Sub-Clause 28.3 hereof; and
- (d) any minor items mentioned in GCC Sub-Clause 24.7 hereof relevant to the Facilities or that part thereof have been completed.

25.3.2 At any time after any of the events set out in GCC Sub-Clause 25.3.1 have occurred, the Implementing Partner may give a notice to the Project Manager requesting the issue of an Operational Acceptance Certificate in the form provided in the Bidding Documents or in another form acceptable to the EESL in respect of the Facilities or the part thereof specified in such notices as at the date of such notice.

25.3.3 The Project Manager shall, after consultation with the EESL, and within forty five (45) days after receipt of the Implementing Partner’s notice, issue an Operational Acceptance Certificate.

25.3.4 If within forty five (45) days after receipt of the Implementing Partner’s notice, the Project Manager fails to issue the Operational Acceptance Certificate or fails to inform the Implementing Partner in writing of the justifiable reasons why the Project Manager has not issued the Operational Acceptance Certificate, the Facilities or the relevant part thereof shall be deemed to have been accepted as at the date of the Implementing Partner’s said notice.

6.21.4 Partial Acceptance

6.21.4.1 If the Contract specifies that Completion and Commissioning shall be carried out in respect of parts of the Facilities, the provisions relating to Completion and Commissioning including the Guarantee Test shall apply to each such part of the Facilities individually, and the Operational Acceptance Certificate shall be issued accordingly for each such part of the Facilities.

6.21.4.2 If a part of the Facilities comprises facilities such as buildings, for which no Commissioning or Guarantee Test is required, then the Project Manager shall issue the Operational Acceptance Certificate for such facility when it attains Completion, provided that the Implementing Partner shall thereafter complete any outstanding minor items that are listed in the Operational Acceptance Certificate.

h) Guarantees and Liabilities

6.22 Completion Time Guarantee

6.22.1 The Implementing Partner guarantees that it shall attain Completion of the Facilities (or a part for which a separate time for completion is specified in the SCC) within the Time for Completion specified in the SCC pursuant to GCC Sub-Clause 8.2, or within such extended time to which the Implementing Partner shall be entitled under GCC Clause 40 (Extension of Time for Completion) hereof.

6.22.2 If the Implementing Partner fails to attain Completion of the Facilities or any part thereof within the Time for Completion or any extension thereof under GCC Clause 40 (Extension of Time for Completion), the Implementing Partner shall pay to the EESL liquidated damages in the amount computed at the rates specified in the SCC. The aggregate amount of such liquidated damages shall in no event exceed the amount specified as “Maximum” in the SCC. Once the “Maximum” is reached, the EESL may consider termination of the Contract, pursuant to GCC Sub-Clause 42.2.2.

Such payment shall completely satisfy the Implementing Partner’s obligation to attain Completion of the Facilities or the relevant part thereof within the Time for Completion or any extension thereof under GCC Clause 40 (Extension of Time for Completion). The Implementing Partner shall have no further liability whatsoever to the EESL in respect thereof.

However, the payment of liquidated damages shall not in any way relieve the Implementing Partner from any of its obligations to complete the Facilities or from any other obligations and liabilities of the Implementing Partner under the Contract.

Save for liquidated damages payable under this GCC Sub-Clause 26.2, the failure by the Implementing Partner to attain any milestone or other act, matter or thing by any date specified in Appendix 4 (Time Schedule) to the Contract Agreement and/or other program of work prepared pursuant to GCC Clause 18 (Program of Performance) shall not render the Implementing Partner liable for any loss or damage thereby suffered by the EESL.

6.23 *Defect Liability (which may also be referred as 'Warranty' mentioned elsewhere in the document)*

6.23.1 The Implementing Partner warrants that the Facilities or any part thereof shall be free from defects in the design, engineering, materials and workmanship of the Plant and Equipment supplied and of the work executed.

6.23.2 The Defect Liability Period shall be eighteen (18) months from the date of Completion of the Facilities (or any part thereof) or twelve (12) months from the date of Operational Acceptance of the Facilities (or any part thereof), whichever first occurs, unless specified otherwise in the SCC.

If during the Defect Liability Period any defect should be found in the design, engineering, materials and workmanship of the Plant and Equipment supplied or of the work executed by the Implementing Partner, the Implementing Partner shall promptly, in consultation and agreement with the EESL regarding appropriate remedying of the defects, and at its cost, repair, replace or otherwise make good (as the Implementing Partner shall, at its discretion, determine) such defects as well as any damage to the Facilities caused by such defect. The Implementing Partner shall not be responsible for the repair, replacement or making good of any defect or of any damage to the Facilities arising out of or resulting from any of the following causes:

- (a) improper operation or maintenance of the Facilities by the EESL
- (b) operation of the Facilities outside specifications provided in the Contract.
- (c) Normal wear and tear.

6.23.3 The Implementing Partner's obligations under this GCC Clause 27 shall not apply to

- (a) any materials that are supplied by the EESL under GCC Sub-Clause 21.2 (EESL-Supplied Plant, Equipment and Materials), are normally consumed in operation, or have a normal life shorter than the Defect Liability Period stated herein.
- (b) any designs, specifications or other data designed, supplied or specified by or on behalf of the EESL or any matters for which the Implementing Partner has disclaimed responsibility herein.
- (c) any other materials supplied or any other work executed by or on behalf of the EESL, except for the work executed by the EESL under GCC Sub-Clause 27.7.

6.23.4 The EESL shall give the Implementing Partner a notice stating the nature of any such defect together with all available evidence thereof, promptly following the discovery thereof. The EESL shall afford all reasonable opportunity for the Implementing Partner to inspect any such defect.

6.23.5 The EESL shall afford the Implementing Partner all necessary access to the Facilities and the Site to enable the Implementing Partner to perform its obligations under this GCC Clause 27.

The Implementing Partner may, with the consent of the EESL, remove from the Site any Plant and Equipment or any part of the Facilities that are defective if the nature of the defect, and/or any damage to the Facilities caused by the defect, is such that repairs cannot be expeditiously carried out at the Site.

6.23.6 If the repair, replacement or making good is of such a character that it may affect the efficiency of the Facilities or any part thereof, the EESL may give to the Implementing Partner a notice requiring that tests of the defective part of the Facilities shall be made by the Implementing Partner immediately upon completion of such remedial work, whereupon the Implementing Partner shall carry out such tests.

If such part fails the tests, the Implementing Partner shall carry out further repair, replacement or making good (as the case may be) until that part of the Facilities passes such tests. The tests in character shall in any case be not less than what has already been agreed by the EESL and the Implementing Partner for the original equipment/part of the Facilities.

6.23.7 If the Implementing Partner fails to commence the work necessary to remedy such defect or any damage to the Facilities caused by such defect within a reasonable time (which shall in no event be considered to be less than fifteen (15) days), the EESL may, following notice to the Implementing Partner, proceed to do such work, and the reasonable costs incurred by the EESL in connection therewith shall be paid to the EESL by the Implementing Partner or may be deducted by the EESL from any monies due to the Implementing Partner or claimed under the Performance Security. After due assessment EESL shall specify the reasonable time in writing to remedy such defect or any damage to the Facilities caused by such defect which shall be more than 15 days.

6.23.8 If the Facilities or any part thereof cannot be used by reason of such defect and/or making good of such defect, the Defect Liability Period of the Facilities or such part, as the case may be, shall be extended by a period equal to the period during which the Facilities or such part cannot be used by the EESL because of any of the aforesaid reasons. Upon correction of the defects in the Facilities or any part thereof by repair/ replacement, such repair/ replacement shall have the Defect Liability Period extended by a period of twelve (12) month from the time such replacement/ repair of the Facilities or any part thereof.

6.23.9 Except as provided in GCC Clauses 27 and 33 (Loss of or Damage to Property / Accident or Injury to Workers/Indemnification), the Implementing Partner shall be under no liability whatsoever and howsoever arising, and whether under the Contract or at law, in respect of defects in the Facilities or any part thereof, the Plant and Equipment, design or engineering or work executed that appear after Completion of the Facilities or any part thereof, except where such defects are the result of the gross negligence, fraud, criminal or wilful action of the Implementing Partner.

6.23.10 In addition, the Implementing Partner shall also provide an extended warranty for any such component of the Facilities and during the period of time as may be specified in the SCC. Such obligation shall be in addition to the defect liability specified under GCC Sub-Clause 27.2.

6.24 Functional Guarantees

6.24.1 The Implementing Partner guarantees that during the Guarantee Test, the Facilities and all parts thereof shall attain the Functional Guarantees specified in Appendix 8 (Functional Guarantees) to the Contract Agreement, subject to and upon the conditions therein specified.

6.24.2 If, for reasons attributable to the Implementing Partner, the guaranteed level of the Functional Guarantees specified in Appendix 8 (Functional Guarantees) to the Contract Agreement are not met either in whole or in part, the Implementing Partner shall, within a mutually agreed time, at its cost and expense make such changes, modifications and/or additions to the Plant or any part thereof as may be necessary to meet such Guarantees. The Implementing Partner shall notify the EESL upon completion of the necessary changes, modifications and/or additions, and shall seek the EESL's consent to repeat the Guarantee Test. If the specified Functional Guarantees are not established even during the repeat of the Guarantee Test, the EESL may at its option, either

- (a) Reject the Equipment and recover the payments already made, or
- (b) Terminate the Contract pursuant to GCC Sub-Clause 42.2.2 and recover the payments already made, or
- (c) Accept the equipment after levy of liquidated damages in accordance with the provisions specified in Appendix-8 (Functional Guarantees) to the Contract Agreement.

6.24.3 In case the EESL exercises its option to accept the equipment after levy of liquidated damages, the payment of liquidated damages under GCC Sub-Clause 28.2, up to the limitation of liability specified in the Appendix-8 (Functional Guarantees) to the Contract Agreement, shall completely satisfy the Implementing Partner's guarantees under GCC Sub-Clause 28.2, and the Implementing Partner shall have no further liability whatsoever to the EESL in respect thereof. Upon the payment of such liquidated damages by the Implementing Partner, the Project Manager shall issue the Operational Acceptance Certificate for the Facilities or any part thereof in respect of which the liquidated damages have been so paid.

6.25 Indemnity for Infringement of Intellectual Property and General Indemnity

Patent Indemnity:

6.25.1 The Implementing Partner shall, subject to the EESL's compliance with GCC Sub-Clause 29.3, indemnify and hold harmless the EESL and its employees and officers from and against any and all suits, actions or administrative proceedings, claims, demands, losses, damages, costs, and expenses of whatsoever nature, including attorney's fees and expenses, which the EESL may suffer as a result of any infringement or alleged infringement of any patent, utility model, registered design, trademark, copyright or other intellectual property right registered or otherwise existing at the date of the Contract by reason of: (a) the installation of the Facilities by the Implementing Partner or the use of the Facilities in the country where the Site is located; and (b) the sale of the products produced by the Facilities in any country.

Such indemnity shall not cover any use of the Facilities or any part thereof other than for the purpose indicated by or to be reasonably inferred from the Contract, any infringement resulting from the use of the Facilities or any part thereof, or any products produced thereby in association or combination with any other equipment, plant or materials not supplied by the Implementing Partner, pursuant to the Contract Agreement.

6.25.2 General Indemnity:

Contractor agrees to indemnify and keep indemnified, defend and hold harmless EESL and its officers, directors, employees, representatives and agents from and against any and all losses, liabilities, claims, damages, obligations, litigations, suits, actions, judgements, costs, expenses and

/ or otherwise including but not limited to those from third parties or liabilities of any kind howsoever suffered or claimed against EESL, (including, without limitation, reasonable attorneys' fees), awarded by court of law or other competent governmental authority or arbitral tribunal or tribunal of competent jurisdiction arising before, during or after completion of services or deliverable (scope of work), which result from, arise in connection with or are related in any way of actions or claims initiated or preferred by third parties or statutory / regulatory authorities, arising out of or in connection with and not limited to:

- (i) The Contractor's breach of the representations and warranties specified in this Contract;
- (ii) Acts or omissions of, negligence, or misconduct by the Contractor; or
 - (iii) The fault or negligence of the Contractor, its officers, employees, agents, subcontractors and/or representations resulting in loss or damage or injury to property or assets or injury to persons or death;
 - (iv) Use of server, machine, equipment or other hardware or Materials or Program and other hardware and software systems, provided by the Contractor directly and/or indirectly and includes non-compatibility of software or hardware in any manner;
 - (v) Defective supplies or servers or other machine parts or materials or program not replaced as contemplated in this Contract;

6.25.3 If any proceedings are brought or any claim is made against the EESL arising out of the matters referred to in GCC Sub-Clause 29.1 or 29.2, the EESL shall promptly give the Implementing Partner a notice thereof, and the Implementing Partner may at its own expense and in the EESL's name conduct such proceedings or claim and any negotiations for the settlement of any such proceedings or claim.

If the Implementing Partner fails to notify the EESL within twenty-eight (28) days after receipt of such notice that it intends to conduct any such proceedings or claim, then the EESL shall be free to conduct the same on its own behalf. Unless the Implementing Partner has so failed to notify the EESL within the twenty-eight (28) day period, the EESL shall make no admission that may be prejudicial to the defense of any such proceedings or claim.

The EESL shall, at the Implementing Partner's request, afford all available assistance to the Implementing Partner in conducting such proceedings or claim, and shall be reimbursed by the Implementing Partner for all reasonable expenses incurred in so doing.

6.26 *Limitation of Liability*

6.26.1 Except in cases of criminal negligence or wilful misconduct or fraud or any criminal misappropriation,

- (a) the Implementing Partner shall not be liable to the EESL, whether in contract, tort, or otherwise, for any indirect or consequential loss or damage, or loss of production, provided that this exclusion shall not apply to any obligation of the Implementing Partner to pay Liquidated Damages to the EESL and
- (b) the aggregate liability of the Implementing Partner to the EESL, whether under the Contract, in tort or otherwise, shall not exceed the total Contract Price, provided that this limitation shall not apply to any obligation of the Implementing Partner to indemnify the EESL with respect to patent infringement or general indemnity or as specified in SCC.

i) *Risk Distribution*

6.27 Transfer of Ownership

6.27.1 Ownership of the Plant and Equipment (including spare parts) procured in the country where the Site is located shall be transferred to the EESL when the Plant and Equipment are reached at site.

6.27.2 Ownership of the Implementing Partner's Equipment used by the Implementing Partner and its Sub Implementing Partners in connection with the Contract shall remain with the Implementing Partner or its Sub Implementing Partners.

6.27.3 Ownership of any Plant and Equipment in excess of the requirements for the Facilities shall revert to the Implementing Partner upon Completion of the Facilities or at such earlier time when the EESL and the Implementing Partner agree that the Plant and Equipment in question are no longer required for the Facilities, provided quantity of any Plant and Equipment specifically stipulated in the Contract shall be the property of the EESL whether or not incorporated in the Facilities.

6.27.4 *Disposal of surplus material*

Ownership of any Plant and Equipment in excess of the requirements for the Facilities (i.e. surplus material) shall revert to the Contractor upon Completion of the Facilities and Guarantee Test or at such earlier time when the Employer and the Contractor agree that the Plant and Equipment in question are no longer required for the Facilities, provided quantity of any Plant and Equipment specifically stipulated in the Contract shall be the property of the Employer whether or not incorporated in the Facilities. The Contractor shall remove from the site such surplus material brought by him in pursuance of the Contract, subject to the Contractor producing the necessary clearance from the relevant authorities (Customs, Excise etc.), if required by law, in respect of re-export or disposal of the surplus material locally. The liability for the payment of the applicable taxes/ duties, if any, on the surplus material so re-exported and/or disposed locally shall be that of the Contractor.

The Contractor shall also indemnify to keep the Employer harmless from any act of omission or negligence on the part of the Contractor in following the statutory requirements with regard to removal / disposal of surplus material. The Indemnity Bond shall be furnished by contractor as per proforma enclosed in Section-VII (Forms and Procedure) as Form No. 14. Further, in case the laws require the Employer to take prior permission of the relevant Authorities before handing over the surplus material to the Contractor, the same shall be obtained by the Contractor on behalf of the Employer.

6.27.5 Notwithstanding the transfer of ownership of the Plant and Equipment, the responsibility for care and custody thereof together with the risk, of loss or damage thereto shall remain with the Implementing Partner pursuant to GCC Clause 32 (Care of Facilities) hereof until Completion of the Facilities or the part thereof in which such Plant and Equipment are incorporated.

31.6 In case of two/three Contracts entered into between the EESL and the Implementing Partner as per GCC Sub-Clause 3.6 or where the EESL hands over his equipment to the Implementing Partner for executing the Contract, then the Implementing Partner shall at the time of taking delivery of the Equipment through Bill of Lading or other despatch documents furnish Trust Receipt for Plant, Equipment and Materials and also execute an Indemnity Bond in favour of the EESL in the form acceptable to EESL for keeping the equipment in safe custody and to utilise the same exclusively for the purpose of the said Contract. Proforma for the Trust Receipt and Indemnity bond. The EESL shall also issue a separate Authorisation Letter to the Implementing Partner to enable him to take physical delivery of plant, equipment and materials from the EESL.

32 Care of Facilities

32.1 The Implementing Partner shall be responsible for the care and custody of the Facilities or any part thereof until the date of Completion of the Facilities pursuant to GCC Clause 24 (Completion of the Facilities) or, where the Contract provides for Completion of the Facilities in parts, until the date of Completion of the relevant part, and shall make good at its own cost any loss or damage that may occur to the Facilities or the relevant part thereof from any cause whatsoever during such period. The Implementing Partner shall also be responsible for any loss or damage to the Facilities caused by the Implementing Partner or its Sub-Implementing Partners in the course of any work carried out, pursuant to GCC Clause 27 (Defect Liability). Notwithstanding the foregoing, the Implementing Partner shall not be liable for any loss or damage to the Facilities or that part thereof caused by reason of any of the matters specified or referred to in paragraphs (a), (b) and (c) of GCC Sub-Clauses 32.2 and 38.1.

32.2 If any loss or damage occurs to the Facilities or any part thereof or to the Implementing Partner's temporary facilities by reason of

- (a) (insofar as they relate to the country where the Site is located) nuclear reaction, nuclear radiation, radioactive contamination, pressure wave caused by aircraft or other aerial objects, or any other occurrences that an experienced Implementing Partner could not reasonably foresee, or if reasonably foreseeable could not reasonably make provision for or insure against, insofar as such risks are not normally insurable on the insurance market and are mentioned in the general exclusions of the policy of insurance, including War Risks and Political Risks, taken out under GCC Clause 34 (Insurance) hereof.
- (b) any use or occupation by the EESL or any third party (other than a Sub-Implementing Partner) authorized by the EESL of any part of the Facilities.
- (c) any use of or reliance upon any design, data or specification provided or designated by or on behalf of the EESL, or any such matter for which the Implementing Partner has disclaimed responsibility herein,

the EESL shall pay to the Implementing Partner all sums payable in respect of the Facilities executed, notwithstanding that the same be lost, destroyed or damaged, and will pay to the Implementing Partner the replacement value of all temporary facilities and all parts thereof lost, destroyed or damaged. If the EESL requests the Implementing Partner in writing to make good any loss or damage to the Facilities thereby occasioned, the Implementing Partner shall make good the same at the cost of the EESL in accordance with GCC Clause 39 (Change in the Facilities). If the EESL does not request the Implementing Partner in writing to make good any loss or damage to the Facilities thereby occasioned, the EESL shall either request a change in accordance with GCC Clause 39 (Change in the Facilities), excluding the performance of that part of the Facilities thereby lost, destroyed or damaged, or, where the loss or damage affects a substantial part of the Facilities, the EESL shall terminate the Contract pursuant to GCC Sub-Clause 42.1 (Termination for EESL's Convenience) hereof, except that the Implementing Partner shall have no entitlement to profit under paragraph (e) of GCC Sub-Clause 42.1.3 in respect of any unexecuted Facilities as at the date of termination.

32.3 The Implementing Partner shall be liable for any loss of or damage to any Implementing Partner's Equipment, or any other property of the Implementing Partner used or intended to be used for purposes of the Facilities, except (i) as mentioned in GCC Sub-Clause 32.2 (with respect to the Implementing Partner's temporary facilities), and (ii) where such loss or damage arises by reason of any of the matters specified in GCC Sub-Clauses 32.2(b) and (c) and 38.1.

32.4 With respect to any loss or damage caused to the Facilities or any part thereof or to the Implementing Partner's Equipment by reason of any of the matters specified in GCC Sub-Clause 38.1, the provisions of GCC Sub-Clause 38.3 shall apply.

33 *Loss of or Damage to Property; Accident or Injury to workers; Indemnification*

33.1 Subject to GCC Sub - Clause 33.3, the Implementing Partner shall indemnify and hold harmless the EESL and its employees and officers from and against any and all suits, actions or administrative proceedings, claims, demands, losses, damages, costs, and expenses of whatsoever nature, including attorney's fees and expenses, in respect of the death or injury of any person or loss of or damage to any property (other than the Facilities whether accepted or not), arising in connection with the supply and installation of the Facilities and by reason of the negligence of the Implementing Partner or its Sub-Implementing Partners, or their employees, officers or agents, except any injury, death or property damage caused by the negligence of the EESL, its Implementing Partners, employees, officers or agents.

33.2 If any proceedings are brought or any claim is made against the EESL that might subject the Implementing Partner to liability under GCC Sub-Clause 33.1, the EESL shall promptly give the Implementing Partner a notice thereof and the Implementing Partner may at its own expense and in the EESL's name conduct such proceedings or claim and any negotiations for the settlement of any such proceedings or claim.

If the Implementing Partner fails to notify the EESL within twenty-eight (28) days after receipt of such notice that it intends to conduct any such proceedings or claim, then the EESL shall be free to conduct the same on its own behalf. Unless the Implementing Partner has so failed to notify the EESL within the twenty-eight (28) day period, the EESL shall make no admission that may be prejudicial to the defense of any such proceedings or claim.

The EESL shall, at the Implementing Partner's request, afford all available assistance to the Implementing Partner in conducting such proceedings or claim, and shall be reimbursed by the Implementing Partner for all reasonable expenses incurred in so doing.

33.3 The EESL shall indemnify and hold harmless the Implementing Partner and its employees, officers and Sub-Implementing Partners from any liability for loss of or damage to property of the EESL, other than the Facilities not yet taken over, that is caused by fire, explosion or any other perils, in excess of the amount recoverable from insurances procured under GCC Clause 34 (Insurances), provided that such fire, explosion or other perils were not caused by any act or failure of the Implementing Partner.

33.4 The party entitled to the benefit of an indemnity under this GCC Clause 33 shall take all reasonable measures to mitigate any loss or damage which has occurred. If the party fails to take such measures, the other party's liabilities shall be correspondingly reduced.

34 *Insurance*

34.1 To the extent specified in Appendix 3 (Insurance Requirements) to the Contract Agreement, the Implementing Partner shall at its expense take out and maintain in effect, or cause to be taken out and maintained in effect, during the performance of the Contract, the insurances set forth below in the sums and with the deductibles and other conditions specified in the said Appendix. The identity of the insurers and the form of the policies shall be subject to the approval of the EESL, who should not Unreasonably withhold such approval.

Cargo Insurance During Transport

Covering loss or damage occurring while in transit from the Implementing Partner's or Sub-Implementing Partner's works or stores until arrival at the Site, to the Plant and Equipment (including spare parts therefor) and to the Implementing Partner's Equipment.

(a) *Installation All Risks Insurance*

Covering physical loss or damage to the Facilities at the Site, occurring prior to Completion of the Facilities, with an extended maintenance coverage for the Implementing Partner's liability in respect of any loss or damage occurring during the Defect Liability Period while the Implementing Partner is on the Site for the purpose of performing its obligations during the Defect Liability Period.

(b) *Third Party Liability Insurance*

Covering bodily injury or death suffered by third parties (including the EESL's personnel) and loss of or damage to property occurring in connection with the supply and installation of the Facilities.

(c) *Automobile Liability Insurance*

Covering use of all vehicles used by the Implementing Partner or its Sub-Implementing Partners (whether or not owned by them) in connection with the execution of the Contract.

(d) *Workers' Compensation*

In accordance with the statutory requirements applicable in any country where the Contract or any part thereof is executed.

(e) *EESL's Liability*

In accordance with the statutory requirements applicable in any country where the Contract or any part thereof is executed.

(f) *Other Insurances*

Such other insurances as may be specifically agreed upon by the parties hereto as listed in the said Appendix 3.

34.2 The EESL shall be named as co-insured under all insurance policies taken out by the Implementing Partner pursuant to GCC Sub-Clause 34.1, except for the Third Party Liability, Workers' Compensation and EESL's Liability Insurances, and the Implementing Partner's Sub-Implementing Partners shall be named as co-insured's under all insurance policies taken out by the Implementing Partner pursuant to GCC Sub-Clause 34.1 except for the Cargo Insurance During Transport, Workers' Compensation and EESL's Liability Insurances. All insurers' rights of subrogation against such co-insured's for losses or claims arising out of the performance of the Contract shall be waived under such policies.

34.3 The Implementing Partner shall, in accordance with the provisions of Appendix 3 (Insurance Requirements) to the Contract Agreement, deliver to the EESL certificates of insurance (or copies of the insurance policies) as evidence that the required policies are in full force and effect. The certificates shall provide that no less than twenty-one (21) days' notice shall be given to the EESL by insurers prior to cancellation or material modification of a policy.

34.4 The Implementing Partner shall ensure that, where applicable, its Sub-Implementing Partner(s) shall take out and maintain in effect adequate insurance policies for their personnel and vehicles and for work executed by them under the Contract, unless such Sub-Implementing Partners are covered by the policies taken out by the Implementing Partner.

34.5 The EESL shall at its expense take out and maintain in effect during the performance of the Contract those insurances specified in Appendix 3 (Insurance Requirements) to the Contract Agreement.

34.6 If the Implementing Partner fails to take out and/or maintain in effect the insurances referred to in GCC Sub-Clause 34.1, the EESL may take out and maintain in effect any such insurances and may from time to time deduct from any amount due the Implementing Partner under the Contract any premium that the EESL shall have paid to the insurer, or may otherwise recover such amount as a debt due from the Implementing Partner. If the EESL fails to take out and/or maintain in effect the insurances referred to in GCC 34.5, the Implementing Partner may take out and maintain in effect any such insurances and may from time to time deduct from any amount due the EESL under the Contract any premium that the Implementing Partner shall have paid to the insurer, or may otherwise recover such amount as a debt due from the EESL. If the Implementing Partner fails to or is unable to take out and maintain in effect any such insurances, the Implementing Partner shall nevertheless have no liability or responsibility towards the EESL, and the Implementing Partner shall have full recourse against the EESL for any and all liabilities of the EESL herein.

34.7 Unless otherwise provided in the Contract, the Implementing Partner shall prepare and conduct all and any claims made under the policies effected by it pursuant to this GCC Clause 34, and all monies payable by any insurers shall be paid to the Implementing Partner as per the procedure outlined in GCC Sub- Clause 34.8 below. The EESL shall give to the Implementing Partner all such reasonable assistance as may be required by the Implementing Partner. With respect to insurance claims in which the EESL’s interest is involved, the Implementing Partner shall not give any release or make any compromise with the insurer without the prior written consent of the EESL. With respect to insurance claims in which the Implementing Partner’s interest is involved, the EESL shall not give any release or make any compromise with the insurer without the prior written consent of the Implementing Partner.

34.8 (i) wherever total damages/loss of equipment/material, would occur, the Implementing Partner will be entitled to payment of all payments received from the underwriters except the following amounts:

(a) The amount paid to the Implementing Partner under the Contract in respect of equipment/material damaged/lost (excluding the pro-rata initial advance) but including the entire amount of escalation, if any, already paid to the Contractor.

(b) Custom Duties and other taxes and duties which have already been paid by the EESL.

In the event the claim money settled, is less than the total of the amount in a & b above, then the entire claim money settled will be retained by the EESL and the Implementing Partner will forthwith pay the EESL the short fall amount between the claim money and the total of amounts as per a & b mentioned above.

Subsequent payments, if any, due under the Contract shall be regulated by the relevant terms of payment.

(II) In case of damage to any equipment/material during any stage, the Implementing Partner upon rectification of the damaged equipment to the satisfaction of the EESL shall be paid to the extent of full claims settled by the underwriters.

35 Unforeseen Conditions

35.1 If, during the execution of the Contract, the Implementing Partner shall encounter on the Site any physical conditions (other than climatic conditions) or artificial obstructions that could not have been reasonably foreseen prior to the date of the Contract Agreement by an experienced Implementing Partner on the basis of reasonable examination of the data relating to the Facilities (including any data as to boring tests) provided by the EESL, and on the basis of information that it could have obtained from a visual inspection of the Site (if access thereto was available) or other data readily available to it relating to the Facilities, and if the Implementing Partner determines that it will in consequence of such conditions or obstructions incur additional cost and expense or require additional time to perform its obligations under the Contract that would not have been required if such physical conditions or artificial obstructions had not been encountered, the Implementing Partner shall promptly, and before performing additional work or using additional Plant and Equipment or Implementing Partner’s Equipment, notify the Project Manager in writing of

- a) the physical conditions or artificial obstructions on the Site that could not have been reasonably foreseen.
- b) the additional work and/or Plant and Equipment and/or Implementing Partner's Equipment required, including the steps which the Implementing Partner will or proposes to take to overcome such conditions or obstructions.
- c) the extent of the anticipated delay.
- d) the additional cost and expense that the Implementing Partner is likely to incur.

On receiving any notice from the Implementing Partner under this GCC Sub-Clause 35.1, the Project Manager shall promptly consult with the EESL and Implementing Partner and decide upon the actions to be taken to overcome the physical conditions or artificial obstructions encountered. Following such consultations, the Project Manager shall instruct the Implementing Partner, with a copy to the EESL, of the actions to be taken.

35.2 Any reasonable additional cost and expense incurred by the Implementing Partner in following the instructions from the Project Manager to overcome such physical conditions or artificial obstructions referred to in GCC Sub-Clause 35.1 shall be paid by the EESL to the Implementing Partner as an addition to the Contract Price.

35.3 If the Implementing Partner is delayed or impeded in the performance of the Contract because of any such physical conditions or artificial obstructions referred to in GCC Sub-Clause 35.1, the Time for Completion shall be extended in accordance with GCC Clause 40 (Extension of Time for Completion).

36 Change in Laws and Regulations

36.1 If, after the date seven (7) days prior to the date of Bid submission, in the country where the Site is located, any law, regulation, ordinance, order or by-law having the force of law is enacted, promulgated, abrogated or changed (which shall be deemed to include any change in interpretation or application by the competent authorities) that subsequently affects the costs and expenses of the Implementing Partner and/or the Time for Completion, the Contract Price shall be correspondingly increased or decreased, and/or the Time for Completion shall be reasonably adjusted to the extent that the Implementing Partner has thereby been affected in the performance of any of its obligations under the Contract. However, these adjustments would be restricted to direct transactions between the EESL and the Implementing Partner/Assignee of Foreign Implementing Partner (if applicable). These adjustment shall not be applicable on procurement of raw materials, intermediary components etc. by the Implementing Partner/Assignee of Foreign Implementing Partner and shall also not be applicable on bought out items despatched directly from sub-vendor works to site. Further, no adjustment of the Contract Price and/or payment or reimbursement of taxes, duties or levies shall be made on account of variation in or withdrawal of Deemed Export benefits. Notwithstanding the foregoing, such additional or reduced costs shall not be separately paid or credited if the same has already been accounted for in the price adjustment provisions where applicable, in accordance with the Appendix 2 to the Contract Agreement.

37 Force Majure

37.1 “Force Majeure” shall mean any event beyond the reasonable control of the EESL or of the Implementing Partner, as the case may be, and which is unavoidable notwithstanding the reasonable care of the party affected.

37.2 If either party is prevented, hindered or delayed from or in performing any of its obligations under the Contract by an event of Force Majeure, then it shall notify the other in writing of the occurrence of such event and the circumstances thereof within fourteen (14) days after the occurrence of such event.

37.3 The party who has given such notice shall be excused from the performance or punctual performance of its obligations under the Contract for so long as the relevant event of Force Majeure continues and to the extent that such party’s performance is prevented, hindered or delayed. The Time for Completion shall be extended in accordance with GCC Clause 40 (Extension of Time for Completion).

37.4 The party or parties affected by the event of Force Majeure shall use reasonable efforts to mitigate the effect thereof upon its or their performance of the Contract and to fulfil its or their obligations under the Contract, but without prejudice to either party’s right to terminate the Contract under GCC Sub-Clauses 37.6 and 38.5.

37.5 No delay or non-performance by either party hereto caused by the occurrence of any event of Force Majeure shall

- a) constitute a default or breach of the Contract
- b) (subject to GCC Sub-Clauses 32.2, 38.3 and 38.4) give rise to any claim for damages or additional cost or expense occasioned thereby

If and to the extent that such delay or non-performance is caused by the occurrence of an event of Force Majeure.

37.6 If the performance of the Contract is substantially prevented, hindered or delayed for a single period of more than sixty (60) days or an aggregate period of more than one hundred and twenty (120) days on account of one or more events of Force Majeure during the currency of the Contract, the parties will attempt to develop a mutually satisfactory solution, failing which the dispute shall be resolved in accordance with GCC Clause 6.

37.7 Notwithstanding GCC Sub-Clause 37.5, Force Majeure shall not apply to any obligation of the EESL to make payments to the Implementing Partner herein.

38 War Risks

38.1 “War Risks” shall mean any of the following events occurring or existing in or near the country (or countries) where the Site is located:

- a) war, hostilities or warlike operations (whether a state of war is declared or not), invasion, act of foreign enemy and civil war
- b) rebellion, revolution, insurrection, mutiny, usurpation of civil or military government, conspiracy, riot, civil commotion and terrorist acts, and
- c) any explosion or impact of any mine, bomb, shell, grenade or other projectile, missile, munitions or explosive of war.

38.2 Notwithstanding anything contained in the Contract, the Implementing Partner shall have no liability whatsoever for or with respect to

- a) destruction of or damage to Facilities, Plant & Equipment, or any part thereof
- b) destruction of or damage to property of the EESL or any third party
- c) injury or loss of life

if such destruction, damage, injury or loss of life is caused by any War Risks, and the EESL shall indemnify and hold the Implementing Partner harmless from and against any and all claims, liabilities, actions, lawsuits, damages, costs, charges or expenses arising in consequence of or in connection with the same.

38.3 If the Facilities or any Plant and Equipment or Implementing Partner's Equipment or any other property of the Implementing Partner used or intended to be used for the purposes of the Facilities shall sustain destruction or damage by reason of any War Risks, the EESL shall pay the Implementing Partner for

- a) any part of the Facilities or the Plant and Equipment so destroyed or damaged (to the extent not already paid for by the EESL)
- b) replacing or making good any Implementing Partner's Equipment or other property of the Implementing Partner so destroyed or damaged so far as may be required by the EESL, and as may be necessary for completion of the Facilities,
- c) replacing or making good any such destruction or damage to the Facilities or the Plant and Equipment or any part thereof.

If the EESL does not require the Implementing Partner to replace or make good any such destruction or damage to the Facilities, the EESL shall either request a change in accordance with GCC Clause 39 (Change in the Facilities), excluding the performance of that part of the Facilities thereby destroyed or damaged or, where the loss, destruction or damage affects a substantial part of the Facilities, shall terminate the Contract, pursuant to GCC Sub-Clause 42.1 (Termination for EESL's Convenience).

38.4 Notwithstanding anything contained in the Contract, the EESL shall pay the Implementing Partner for any increased costs or incidentals to the execution of the Contract that are in any way attributable to, consequent on, resulting from, or in any way connected with any War Risks, provided that the Implementing Partner shall as soon as practicable notify the EESL in writing of any such increased cost.

38.5 If during the performance of the Contract any War Risks shall occur that financially or otherwise materially affect the execution of the Contract by the Implementing Partner, the Implementing Partner shall use its reasonable efforts to execute the Contract with due and proper consideration given to the safety of its and its Sub-Implementing Partners' personnel engaged in the work on the Facilities, provided, however, that if the execution of the work on the Facilities becomes impossible or is substantially prevented for a single period of more than sixty (60) days or an aggregate period of more than one hundred and twenty (120) days on account of any War Risks, the parties will attempt to develop a mutually satisfactory solution, failing which the dispute will be resolved in accordance with GCC Clause 6.

38.6 In the event of termination pursuant to GCC Sub-Clauses 38.3, the rights and obligations of the EESL and the Implementing Partner shall be specified in GCC Sub-Clauses 42.1.2 and 42.1.3, except that the Implementing Partner shall have no entitlement to profit under paragraph (e) of GCC Sub-Clause 42.1.3 in respect of any unexecuted Facilities as of the date of termination.

j) Change in Contract Element

39.1 Changes in the Facilities

39.1.1 The EESL shall have the right to propose, and subsequently require, that the Project Manager order the Implementing Partner from time to time during the performance of the Contract to make any change, modification, addition or deletion to, in or from the Facilities (hereinafter called "Change"), provided that such Change falls within the general scope of the Facilities and does not constitute unrelated work and that it is technically practicable, taking into account both the state of advancement of the Facilities and the technical compatibility of the Change envisaged with the nature of the Facilities as specified in the Contract.

39.1.2 The Implementing Partner may from time to time during its performance of the Contract propose to the EESL (with a copy to the Project Manager) any Change that the Implementing Partner considers necessary or desirable to improve the quality, efficiency or safety of the Facilities. The EESL may at its discretion approve or reject any Change proposed by the Implementing Partner.

39.1.3 Notwithstanding GCC Sub-Clauses 39.1.1 and 39.1.2, no change made necessary because of any default of the Implementing Partner in the performance of its obligations under the Contract shall be deemed to be a Change, and such change shall not result in any adjustment of the Contract Price or the Time for Completion.

39.1.4 The procedure on how to proceed with and execute Changes is specified in GCC Sub-Clauses 39.2 and 39.3.

39.2 Changes Originating from EESL

If the EESL proposes a Change pursuant to GCC Sub-Clause 39.1.1, it shall send to the Implementing Partner a "Request for Change Proposal," requiring the Implementing Partner to prepare and furnish to the Project Manager as soon as reasonably practicable a "Change Proposal," which shall include the following:

- a) brief description of the Change
- b) effect on the Time for Completion
- c) estimated cost of the Change
- d) effect on Functional Guarantees (if any)
- e) effect on any other provisions of the Contract.

39.2.2 The pricing of any Change shall, as far as practicable, be calculated in accordance with the rates and prices included in the Contract. If the rates and prices of any change are in the Contract, the parties thereto shall agree on specific rates for the valuation of the Change.

39.2.3 If before or during the preparation of the Change Proposal it becomes apparent that the aggregate effect of compliance therewith and with all other Change Orders that have already become binding upon the Implementing Partner under this GCC Clause 39 would be to increase or decrease the Contract Price as originally set forth in Article 2 (Contract Price) of the Contract Agreement by more than fifteen (15) percent, the Implementing Partner may give a written notice of objection thereto prior to furnishing the Change Proposal as aforesaid. If the EESL accepts the Implementing Partner's objection, the EESL and the Implementing Partner shall agree on specific rates for valuation of the change.

39.2.4 Upon receipt of the Change Proposal, the EESL and the Implementing Partner shall mutually agree upon all matters therein contained including agreement on rates if such rates are not available in the Contract or if the limit of 15% set forth in Clause 39.2.3 has been exceeded. Within fourteen (14) days after such agreement, the EESL shall, if it intends to proceed with the Change, issue the Implementing Partner with a Change Order.

If the EESL is unable to reach a decision within fourteen (14) days, it shall notify the Implementing Partner with details of when the Implementing Partner can expect a decision.

If the EESL decides not to proceed with the Change for whatever reason, it shall, within the said period of fourteen (14) days, notify the Implementing Partner accordingly.

39.2.5 If the EESL and the Implementing Partner cannot reach agreement on the price for the Change, an equitable adjustment to the Time for Completion, or any other matters identified in the Change Proposal, the EESL may nevertheless instruct the Implementing Partner to proceed with the Change by issue of a "Pending Agreement Change Order."

Upon receipt of a Pending Agreement Change Order, the Implementing Partner shall immediately proceed with effecting the Changes covered by such Order. The parties shall thereafter attempt to reach agreement on the outstanding issues under the Change Proposal.

39.3 Changes Originating from Implementing Partner

39.3.1 If the Implementing Partner proposes a Change pursuant to GCC Sub-Clause 39.1.2, the Implementing Partner shall submit to the Project Manager a written "Application for Change Proposal," giving reasons for the proposed Change and including the information specified in GCC Sub-Clause 39.2.1.

Upon receipt of the Application for Change Proposal, the parties shall follow the procedures outlined in GCC Sub-Clauses 39.2.4 and 39.2.5

40. Extension of Time for Completion

40.1 The Time(s) for Completion specified in the SCC shall be extended if the Implementing Partner has delayed or impeded in the performance of any of its obligations under the Contract by reason of any of the following:

- a) any Change in the Facilities as provided in GCC Clause 39 (Change in the Facilities)
- b) any occurrence of Force Majeure as provided in GCC Clause 37 (Force Majeure), unforeseen conditions as provided in GCC Clause 35 (Unforeseen Conditions), or other occurrence of any of the matters specified or referred to in paragraphs (a), (b) and (c) of GCC Sub-Clause 32.2
- c) any suspension order given by the EESL under GCC Clause 41 (Suspension) hereof or reduction in the rate of progress pursuant to GCC Sub-Clause 41.2 or
- d) any changes in laws and regulations as provided in GCC Clause 36 (Change in Laws and Regulations) or
- e) any default or breach of the Contract by the EESL, specifically including failure to supply the items listed in Appendix 6 (Scope of Works and Supply by the EESL) to the Contract Agreement, or any activity, act or omission of any other Implementing Partners employed by the EESL or
- f) any other matter specifically mentioned in the Contract;

by such period as shall be fair and reasonable in all the circumstances and as shall fairly reflect the delay or impediment sustained by the Implementing Partner.

40.2 Except where otherwise specifically provided in the Contract, the Implementing Partner shall submit to the Project Manager a notice of a claim for an extension of the Time for Completion (at EESL's discretion whether to levy LD), together with particulars of the event or circumstance justifying such extension as soon as reasonably practicable after the commencement of such event or circumstance. As soon as reasonably practicable after receipt of such notice and supporting particulars of the claim, the EESL and the Implementing Partner shall agree upon the period of such extension. In the event that the Implementing Partner does not accept the EESL's estimate of a fair and reasonable time extension, the Implementing Partner shall be entitled to refer the matter to the Arbitration, pursuant to GCC Sub-Clause 6.2 (Arbitration).

40.3 The Implementing Partner shall at all times use its reasonable efforts to minimize any delay in the performance of its obligations under the Contract.

41 Suspension

41.1 EESL may, by notice to the Implementing Partner, order the Implementing Partner to suspend performance of any or all of its obligations under the Contract. Such notice shall specify the

obligation of which performance is to be suspended, the effective date of the suspension and the reasons therefore. The Implementing Partner shall thereupon suspend performance of such obligation (except those obligations necessary for the care or preservation of the Facilities or continuity of the project or for the continuity of essential SLAs/activity's) under the project) until ordered in writing to resume such performance by the Project Manager/ EESL.

If, by virtue of a suspension order given by the Project Manager/EESL other than by reason of the Implementing Partner's default or breach of the Contract, the Implementing Partner's performance of any of its obligations is suspended for an aggregate period of more than ninety (90) days, then at any time thereafter and provided that at that time such performance is still suspended, the Implementing Partner may give a notice to the Project Manager requiring that the EESL shall, within twenty-eight (28) days of receipt of the notice, order the resumption of such performance or request and subsequently order a change in accordance with GCC Clause 39 (Change in the Facilities), excluding the performance of the suspended obligations from the Contract.

If the EESL fails to do so within such period, the Implementing Partner may, by a further notice to the Project Manager, elect to treat the suspension, where it affects a part only of the Facilities, as a deletion of such part in accordance with GCC Clause 39 (Change in the Facilities) or, where it affects the whole of the Facilities, as termination of the Contract under GCC Sub-Clause 42.1 (Termination for EESL's Convenience).

41.2 If

- a) the EESL has failed to pay the Implementing Partner any sum due under the Contract within the specified period, has failed to approve any invoice or supporting documents without just cause pursuant to Appendix 1 (Terms and Procedures of Payment) to the Contract Agreement, or commits a substantial breach of the Contract, the Implementing Partner may give a notice to the EESL that requires payment of such sum, requires approval of such invoice or supporting documents, or specifies the breach and requires the EESL to remedy the same, as the case may be. If the EESL fails to pay such sum, fails to approve such invoice or supporting documents or give its reasons for withholding such approval, or fails to remedy the breach or take steps to remedy the breach within sixty (60) days after receipt of the Implementing Partner's notice or
- b) the Implementing Partner is unable to carry out any of its obligations under the Contract for any reason solely attributable to the EESL, including but not limited to the EESL's failure to provide possession of or access to the Site or other areas in accordance with GCC Sub-Clause 10.2, or failure to obtain any governmental permit necessary for the execution and/or completion of the Facilities; then the Implementing Partner may by fourteen (14) days' notice to the EESL suspend performance of all or any of its obligations under the Contract, or reduce the rate of progress.

41.3 If the Implementing Partner's performance of its obligations is suspended or the rate of progress is reduced pursuant to this GCC Clause 41, then the Time for Completion shall be extended in accordance with GCC Sub-Clause 40.1, and any and all additional costs or expenses incurred by the Implementing Partner as a result of such suspension or reduction shall be paid by the EESL to the Implementing Partner in addition to the Contract Price, except in the case of suspension or reduction in the rate of progress by reason of the Implementing Partner's default or breach of the Contract.

41.4 During the period of suspension, the Implementing Partner shall not remove from the Site any Plant and Equipment, any part of the Facilities or any Implementing Partner's Equipment, without the prior written consent of the EESL. Additionally, the Implementing Partner shall not remove any deliverable already installed. Also, the Implementing Partner shall be obligated to install the deliverable or complete the work as per the scope for which directions have been issued by EESL.

42 Termination

42.1 Termination for EESL's Convenience

42.1.1 The EESL may at any time terminate the Contract for any reason by giving the Implementing Partner a notice of termination that refers to this GCC Sub-Clause 42.1.

42.1.2 Upon receipt of the notice of termination under GCC Sub-Clause 42.1.1, the Implementing Partner shall either immediately or upon the date specified in the notice of termination

- (a) cease all further work, except for such work as the EESL may specify in the notice of termination for the sole purpose of protecting that part of the Facilities already executed, or any work required to leave the Site in a clean and safe condition
- (b) terminate all subcontracts, except those to be assigned to the EESL pursuant to paragraph (d)(ii) below
- (c) remove all Implementing Partner's Equipment from the Site, repatriate the Implementing Partner's and its Sub Implementing Partners' personnel from the Site, remove from the Site any wreckage, rubbish and debris of any kind, and leave the whole of the Site in a clean and safe condition.
- (d) In addition, the Implementing Partner, subject to the payment specified in GCC Sub-Clause 42.1.3, shall
 - (i) Deliver to the EESL the parts of the Facilities executed by the Implementing Partner up to the date of termination
 - (ii) to the extent legally possible, assign to the EESL all right, title and benefit of the Implementing Partner to the Facilities and to the Plant and Equipment as at the date of termination, and, as may be required by the EESL, in any subcontracts concluded between the Implementing Partner and its Sub Implementing Partners

(iii) deliver to the EESL all non-proprietary drawings, specifications and other documents prepared by the Implementing Partner or its Sub Implementing Partners as at the date of termination in connection with the Facilities.

42.1.3 In the event of termination of the Contract under GCC Sub-Clause 42.1.1, the EESL shall pay to the Implementing Partner the following amounts:

- (a) the Contract Price, properly attributable to the parts of the Facilities executed by the Implementing Partner as of the date of termination
- (b) the costs reasonably incurred by the Implementing Partner in the removal of the Implementing Partner's Equipment from the Site and in the repatriation of the Implementing Partner's and its Sub Implementing Partners' personnel.
- (c) any amounts to be paid by the Implementing Partner to its Sub Implementing Partners in connection with the termination of any subcontracts, including any cancellation charges.
- (d) costs incurred by the Implementing Partner in protecting the Facilities and leaving the Site in a clean and safe condition pursuant to paragraph (a) of GCC Sub-Clause 42.1.2
- (e) the cost of satisfying all other obligations, commitments and claims that the Implementing Partner may in good faith have undertaken with third parties in connection with the Contract and that are not covered by paragraphs (a) through (d) above.

42.2 Termination for Contractor or Implementing Partner's Default

42.2.1 The EESL, without prejudice to any other rights or remedies it may possess, may terminate the Contract forthwith in the following circumstances by giving a notice of termination and its reasons therefor to the Implementing Partner, referring to this GCC Sub-Clause 42.2:

- (a) if the Implementing Partner becomes bankrupt or insolvent, has a receiving order issued against it, compounds with its creditors, or, if the Implementing Partner is a corporation, a resolution is passed or order is made for its winding up (other than a voluntary liquidation for the purposes of amalgamation or reconstruction), a receiver is appointed over any part of its undertaking or assets, or if the Implementing Partner takes or suffers any other analogous action in consequence of debt.
- (b) if the Implementing Partner assigns or transfers the Contract or any right or interest therein in violation of the provision of GCC Clause 43 (Assignment).
- (c) if the Implementing Partner, in the judgement of the EESL has engaged in corrupt or fraudulent practices in competing for or in executing the Contract.

For the purpose of this Sub-Clause:

"corrupt practice" means the offering, giving, receiving or soliciting of anything of value to influence the action of a public official in the procurement process or in contract execution.

"fraudulent practice" means a misrepresentation of facts in order to influence a procurement process or the execution of a contract to the detriment of the EESL and includes collusive practice among Contractors (prior to or after bid submission) designed to establish bid prices at artificial non-competitive levels and to deprive the EESL of the benefits of free and open competition.

42.2.2 If the Implementing Partner

- (a) has abandoned or repudiated the Contract
- (b) has without valid reason failed to commence work on the Facilities promptly or has suspended (other than pursuant to GCC Sub-Clause 41.2) the progress of Contract performance for more than twenty-eight (28) days after receiving a written instruction from the EESL to proceed
- (c) persistently fails to execute the Contract in accordance with the Contract or persistently neglects to carry out its obligations under the Contract without just cause
- (d) refuses or is unable to provide sufficient materials, services or labour to execute and complete the Facilities in the manner specified in the program furnished under GCC Clause 18 (Program of Performance) at rates of progress that give reasonable assurance to the EESL that the Implementing Partner can attain Completion of the Facilities by the Time for Completion as extended

then the EESL may, without prejudice to any other rights it may possess under the Contract, give a notice to the Implementing Partner stating the nature of the default and requiring the Implementing Partner to remedy the same. If the Implementing Partner fails to remedy or to take steps to remedy the same within fourteen (14) days of its receipt of such notice, then the EESL may terminate the Contract forthwith by giving a notice of termination to the Implementing Partner that refers to this GCC Sub-Clause 42.2.

42.2.3 Upon receipt of the notice of termination under GCC Sub-Clauses 42.2.1 or 42.2.2, the Implementing Partner shall, either immediately or upon such date as is specified in the notice of termination, cease all further work, except for such work as the EESL may specify in the notice of termination, or any work required to leave the Site in a clean and safe condition

- (a) terminate all subcontracts, except those to be assigned to the EESL pursuant to paragraph (d) below
- (b) deliver to the EESL the parts of the Facilities executed by the Implementing Partner up to the date of termination.
- (c) to the extent legally possible, assign to the EESL all right, title and benefit of the Implementing Partner to the Works. and to the Plant and Equipment as at the date of termination, and, as may be required by the EESL, in any subcontracts concluded between the Implementing Partner and its Sub Implementing Partners.
- (d) deliver to the EESL all drawings, specifications and other documents prepared by the Implementing Partner or its Sub Implementing Partners as at the date of termination in connection with the Facilities.

42.2.4 The EESL may enter upon the Site, expel the Implementing Partner, and complete the Facilities itself or by employing any third party. The EESL may, to the exclusion of any right of the Implementing Partner over the same, take over and use with the payment of a fair rental rate to the Implementing Partner, with all the maintenance costs to the account of the EESL and with an indemnification by the EESL for all liability including damage or injury to persons arising out of the EESL's use of such equipment, any Implementing Partner's Equipment owned by the Implementing Partner and on the Site in connection with the Facilities for such reasonable period as the EESL considers expedient for the supply and installation of the Facilities.

Upon completion of the Facilities or at such earlier date as the EESL thinks appropriate, the EESL shall give notice to the Implementing Partner that such Implementing Partner's Equipment will be returned to the Implementing Partner at or near the Site and shall return such Implementing Partner's Equipment to the Implementing Partner in accordance with such notice. The Implementing Partner shall thereafter without delay and at its cost remove or arrange removal of the same from the Site.

42.2.5 Subject to GCC Sub-Clause 42.2.6, the Implementing Partner shall be entitled to be paid the Contract Price attributable to the Facilities executed as at the date of termination, the value of any unused or partially used Plant and Equipment on the Site, and the costs, if any, incurred in protecting the Facilities and in leaving the Site in a clean and safe condition pursuant to paragraph (a) of GCC Sub-Clause 42.2.3. Any sums due to the EESL from the Implementing Partner accruing prior to the date of termination shall be deducted from the amount to be paid to the Implementing Partner under this Contract.

42.2.6 If the EESL completes the Facilities, the cost of completing the Facilities by the EESL shall be determined.

If the sum that the Implementing Partner is entitled to be paid, pursuant to GCC Sub-Clause 42.2.5, plus the reasonable costs incurred by the EESL in completing the Facilities, exceeds the Contract Price, the Implementing Partner shall be liable for such excess.

If such excess is greater than the sums due to the Implementing Partner under GCC Sub-Clause 42.2.5, the Implementing Partner shall pay the balance to the EESL, and if such excess is less than the sums due to the Implementing Partner under GCC Sub-Clause 42.2.5, the EESL shall pay the balance to the Implementing Partner.

The EESL and the Implementing Partner shall agree, in writing, on the computation described above and the manner in which any sums shall be paid.

42.3 Notice by Contractor or Implementing Partner

42.3.1 If

(a) the EESL has failed to pay the Implementing Partner any sum due under the Contract within the specified period, has failed to approve any invoice or supporting documents without just cause pursuant to Appendix 1 (Terms and Procedures of Payment) of the Contract Agreement, or commits a substantial breach of the Contract, the Implementing Partner may give a notice to the EESL that requires payment of such sum, requires approval of such invoice or supporting documents, or specifies the breach and requires the EESL to remedy the same, as the case may be. If the EESL fails to pay such sum, fails to approve such invoice or supporting documents or give its reasons for withholding such approval, fails to remedy the breach or take steps to remedy the breach within fourteen (14) days after receipt of the Implementing Partner's notice.

43. Assignment

The Implementing Partner shall not, without the express prior written consent of the EESL, assign to any third party the Contract or any part thereof, or any right, benefit, obligation or interest therein or thereunder, except that the Implementing Partner shall be entitled to assign either absolutely or by way of charge any monies due and payable to it or that may become due and payable to it under the Contract.

44. Bankruptcy

If the Contractor shall become bankrupt or have a receiving order made against him or compound with his creditors, or being a corporation commence to be wound up, not being a voluntary winding up for the purpose only of amalgamation / reconstruction, or carry on its business under a receiver for the benefit of its creditors or any of them, the Owner will be at liberty :

to terminate the contract forthwith by notice in writing to the liquidator or receiver or to any person in whom the contract may become vested & to act in the manner provided in GCC clause 42 entitled "Termination" as though the last mentioned notice has been the notice referred to in such clause and the equipment and materials have been taken out of the contractor's hands.

to give such liquidator, receiver or other person, the option of carrying out the contract subject to his providing a guarantee, for the due and faithful performance of the contract up to an amount to be determined by the Owner.

45. Contractor Performance & Feedback and Evaluation System

The Employer has a right to evaluate 'Contractor Performance', wherein during the execution of contract performance of contractor shall be evaluated on a continuous basis at regular intervals under the heads such as but not limited to a) Financial Status; b) Project Execution & Project Management Capability; c) Engineering & QA Capability and d) Claims and Disputes. In case the performance of the contractor is found unsatisfactory on any of the above four parameters, the contractor shall be considered ineligible for participating in future tenders for a period as may be decided by the Employer in line with the relevant provision of Policy and Procedure for withholding and Banning of Business Dealings, as applicable.

46. *Fraud Prevention Policy*

The contractor along with their associate/collaborator/sub-contractors/sub-vendors/consultants/service providers shall strictly adhere to the Fraud Prevention Policy of EESL displayed on its tender website www.eeslindia.org

The Contractor along with their associate/collaborator/sub-contractors/sub-vendors/consultants/service providers shall observe the highest standard of ethics and shall not indulge or allow anybody else working in their organization to indulge in fraudulent activities during execution of the contract. The contractor shall immediately apprise the Employer about any fraud or suspected fraud as soon as it comes to their notice.

47. *Audit:*

47.1 EESL reserves the right to audit, at its expense, Contractors accounts and document pertaining to scope of work under this contract in each six (6) month period after providing reasonable written notice of at least fifteen (15) days. The audit shall be conducted without distributing the day to day work the Contractor and shall be focused and limited to the document, accounts or information pertaining to activities under this Contract.

SECTION-4

Part- A (Bid Data Sheet) of Section-4

Part-A (Bid Data Sheet) of Section-4

The following bid specific data shall amend and/or supplement the provisions in the Instructions to Bidders (ITB):

Sl. No.	ITB Clause Ref. No.	Bid Data Details				
1.	ITB 1.1.1	<p>Supplement ITB 1.1.1 with the following:</p> <p>The number of Invitation for Bid (IFB) is: -</p> <p>The Purchaser/Employer is Energy Efficiency Services Limited</p> <p>The No. and Identification of Lots/Package/Schedule comprising this Open Competitive Bidding (OCB) is as per the following Details:</p> <table border="1"> <thead> <tr> <th>Sl. No.</th> <th>Lot No/ Package/ Schedule</th> </tr> </thead> <tbody> <tr> <td>1.</td> <td>Refurbishment and Repair & Maintenance of CCMS along with comprehensive on-site warranty (including supply of spares parts) for a period until the project completion of respective ULB in Street lighting project in the state of Telangana</td> </tr> </tbody> </table>	Sl. No.	Lot No/ Package/ Schedule	1.	Refurbishment and Repair & Maintenance of CCMS along with comprehensive on-site warranty (including supply of spares parts) for a period until the project completion of respective ULB in Street lighting project in the state of Telangana
Sl. No.	Lot No/ Package/ Schedule					
1.	Refurbishment and Repair & Maintenance of CCMS along with comprehensive on-site warranty (including supply of spares parts) for a period until the project completion of respective ULB in Street lighting project in the state of Telangana					
2.	ITB 1.1.1	<p>Supplement ITB 1.1.1 with the following:</p> <p>The Employer is: M/s. Energy Efficiency Services Limited, Buddha Bhawan, 3rd Floor, North block, MG Road Ranigunj, Secunderabad-500003, Telangana Kind Attn: Addl. General Manager (Contracts) Email: - asrao@eesl.co.in / u_esrinivas@eesl.co.in</p> <p>For the purpose of execution of the contract, the contractual activities shall be performed by the Employer "for and on behalf of the Owner" except in cases where the Owner itself is statutorily required to do so.</p>				
3.	ITB 1.1.2	<p>Supplementing clause ITB 1.1.2 as per the following:</p> <p>Eligible Bidders:</p> <p>Any Bidder from a country which shares a land border with India will be eligible to bid only if the Bidder is registered with the Competent Authority as per order no. F.No.6/18/2019-PPD (Order Public Procurement no.1) dated 23/07/2020 and F.No.6/18/2019-PPD (Order Public Procurement no.2) dated 23/07/2020 including all its subsequent order/notices in this regard, issued by Public Procurement Division, Department of Expenditure, Ministry of Finance, Government of India (DoE Order). Registration should be valid at the time of submission of bids and at the time of Award</p>				

Sl. No.	ITB Clause Ref. No.	Bid Data Details
		<p>However, the aforesaid condition for registration of Bidders from countries (even if sharing land border with India) shall not be applicable to Bidders from such countries to which Government of India has extended lines of credit or in which Government of India is engaged in development projects.</p> <p>For the aforesaid purpose,</p> <p>a. "Bidder" means any person or firm or company, every artificial juridical persons not falling in any of the descriptions of bidders stated hereinbefore, including any agency branch or office controlled by such person, participating in a procurement process.</p> <p>b. "Bidder from a country which shares a land border with India" for this purpose means:</p> <ul style="list-style-type: none"> • An entity incorporated, established or registered in such a country; or • A subsidiary of an entity incorporated, established or registered in such a country; or • An entity substantially controlled through entities incorporated, established or registered in such a country; or • An entity whose beneficial owner is situated in such a country; or • An Indian (or other) agent of such an entity; or • A natural person who is a citizen of such a country; or • A consortium or joint venture where any member of the consortium or joint venture falls under any of the above. <p>c. The beneficial owner for the purpose of (ii) (d) above will be under:</p> <p>1. In case of a company or Limited Liability Partnership, the beneficial owner is the natural person(s), who, whether acting alone or together, or through one or more juridical person, has controlling ownership interests or who exercises control through other means</p> <p style="padding-left: 40px;">Explanation -</p> <p style="padding-left: 40px;">"Controlling ownership interest" means ownership of or entitlement to more than twenty-five percent of shares or capital or profits of the company</p> <p style="padding-left: 40px;">"Control" shall include the right to appoint majority of the directors or to control the management or policy decisions including by virtue of their shareholding or management rights or shareholders agreement or voting rights;</p> <p>2. In case of a partnership firm, the beneficial owner is the natural person(s) who, whether acting alone or together, or through one or more juridical person, has ownership of entitlement to more than fifteen percent of capital or profits of the partnership.</p>

Sl. No.	ITB Clause Ref. No.	Bid Data Details
		<p>3. In case of an unincorporated association or body of individuals, the beneficial owner is the natural person(s), who, whether acting alone or together, or through one or more juridical person, has ownership of or entitlement to more than fifteen percent of the property or capital or profits of such association or body of individuals</p> <p>4. Where no natural person is identified under (1) or (2) or (3) above, the beneficial owner is the relevant natural person who holds the position of senior managing official.</p> <p>5. In case of a trust, the identification of beneficial owner(s) shall include identification of the author of the trust, the trustee, the beneficiaries with fifteen percent or more interest in the trust and any other natural person exercising ultimate effective control over the trust through a chain of control or ownership.</p> <p>An Agent is a person employed to do any act for another, or to represent another in dealings with third person.</p> <p>Further, the successful Bidder shall not be allowed to sub-contract works to any contractor from a country which shares a land border with India unless such contractor is registered with the Competent Authority. This restriction on subcontracting shall not be applicable for procurement of raw materials, components, sub-assemblies etc. However, in case of finished goods procured directly/indirectly from the vendors from the countries sharing land border with India, such vendor will be required to be registered with the Competent Authority.</p> <p>The Bidder shall in its bid submit a certificate in compliance to DoE order as per the given format.</p> <p>(Further, the firm has to be a 'Class-I local supplier' as defined under Public Procurement (Preference to Make in India) Order, 2017 issued by Department for promotion of Industry and Internal Trade (DPIIT), Ministry of Commerce and Industry, Government of India vide order dated 15/06/2017, its revision dated 16/09/2020 (PPP-MII Order) read in conjunction with 'Public Procurement (Preference to Make in India) to provide for Purchase Preference (linked with local content) in respect of Power Sector' order dated 16/11/2021 issued by Ministry of Power (MoP Order) subsequent modifications/amendments if any.</p> <p>Firms who are not 'Class-I local supplier' shall not be eligible to bid.</p> <p>Presently, the local content requirement to categorize a supplier as 'Class-I local supplier' is minimum 60%</p>

Sl. No.	ITB Clause Ref. No.	Bid Data Details
		<p>The 'Class-I local supplier' shall give a self- certification in his bid in the given format, indicating the percentage of Local Content and certifying that the item offered meets the Local Content requirement for 'Class -I local supplier' and shall give details of the location(s) at which value addition is made. Further, in case of packages above Rs. 10 Cr, the 'Class-I local supplier' shall provide a certificate from statutory auditor or cost auditor of the company (in the case of companies) or from a practicing cost accountant or practicing chartered accountant (in respect of suppliers other than companies) giving the percentage of Local Content. Any false declaration regarding Local Content by the bidder shall be taken in line with provisions of the PPP- MII Order.</p> <p>Further, entities of countries which have been identified by the Nodal Ministry/Department identified under PPP-MII order, as not allowing Indian companies to participate in their Government procurement for any item related to that Nodal Ministry shall not be allowed to participate in bidding for all items related to that Nodal Ministry/Department, except for the list of items published by the Ministry/Department permitting their participation. The term 'entity' of a country shall have the same meaning as under the FDI Policy of DPIIT as amended from time to time.</p>
4.	ITB 1.2	<p>Supplementing ITB 1.2 with the following: M/s. Energy Efficiency Services Limited, Buddha Bhawan, 3rd Floor, North block, MG Road Ranigunj, Secunderabad-500003, Telangana Kind Attn: Addl. General Manager (Contracts) Email: - asrao@eesl.co.in / u_esrinivas@eesl.co.in,</p> <p>Further, it may be mentioned that Pre-bid meeting will be conducted for this tender as per detail provided in Section-1 IFB.</p> <p>However, a query may be forwarded to EESL in the following format within 06 days of floating of inquiry.</p>

Sl. No.	ITB Clause Ref. No.	Bid Data Details														
				Name of Tender												
		Tender No.														
		Tender ID														
		Bid Opening Date														
		Bidder's Name														
		Contact person from Bidder with address, e-mail and Contact No.														
		Sl. No.	Section No.	Description as per RfP	Queries/ Clarification of the bidder	Remarks										
			Page No.													
			Para No./ Clause No.													
		1.	Section No.													
				Page No.												
				Para No./ Clause No.												
		2.	Section No.													
				Page No.												
				Para No./ Clause No.												
		3.	Section No.													
				Page No.												
				Para No./ Clause No.												
5.	ITB 1.4	<p>Supplementing ITB 1.4 with the following:</p> <p>All the Bidders except those exempted pursuant to Annexure-II shall submit along with the hard copy part of bid a non-refundable fee as INR. 25,000.00 (Twenty Five Thousand Only) towards the cost of Bidding Documents in the form of demand draft in favour of Energy Efficiency Services Limited, payable at New Delhi.</p> <p>Bid Fee may also be submitted online through RTGS. The detail of RTGS is as mentioned below:</p> <table border="1" data-bbox="457 1323 1378 1701"> <thead> <tr> <th>Account Name</th> <th>Account No.</th> <th>Bank Name</th> <th>Branch Name</th> <th>RTGS DETAIL</th> </tr> </thead> <tbody> <tr> <td>ENERGY EFFICIENCY SERVICES LIMITED</td> <td>2164002100012319</td> <td>Punjab National Bank</td> <td>LARGE CORPORATE BRIN DELHI</td> <td>IFSC CODE: PUNB0216400 MICR Code: 110751001 BRANCH: DELHI NEW, L.C.B. ADDRESS: TOLSTOY HOUSE, TOLSTOY MARG, NEWDELHI, DELHI-110001</td> </tr> </tbody> </table>					Account Name	Account No.	Bank Name	Branch Name	RTGS DETAIL	ENERGY EFFICIENCY SERVICES LIMITED	2164002100012319	Punjab National Bank	LARGE CORPORATE BRIN DELHI	IFSC CODE: PUNB0216400 MICR Code: 110751001 BRANCH: DELHI NEW, L.C.B. ADDRESS: TOLSTOY HOUSE, TOLSTOY MARG, NEWDELHI, DELHI-110001
Account Name	Account No.	Bank Name	Branch Name	RTGS DETAIL												
ENERGY EFFICIENCY SERVICES LIMITED	2164002100012319	Punjab National Bank	LARGE CORPORATE BRIN DELHI	IFSC CODE: PUNB0216400 MICR Code: 110751001 BRANCH: DELHI NEW, L.C.B. ADDRESS: TOLSTOY HOUSE, TOLSTOY MARG, NEWDELHI, DELHI-110001												

Sl. No.	ITB Clause Ref. No.	Bid Data Details
		<p>Note: Bidders submitting Bid Fee through RTGS shall upload the scan copy of receipt of transfer of amount in Envelope-I. Participation of bidder shall be subject to confirmation of amount transferred through RTGS. The details mentioned in document uploaded as proof of transfer of amount shall only be considered for verification purpose.</p> <p>Bidder's failure to submit non-refundable fee towards the cost of Bidding Documents in the form of an acceptable Demand Draft along with the bid or an online payment through EESL ONLINE PAYMENT UTILITY or subsequently pursuant to Clarification as per ITB 4.2, except as exempted, shall lead to outright rejection of the Bid.</p>
6.	ITB 2.1	<p>Replace ITB 2.1 with the following:</p> <p>Bids shall be submitted in Single Stage Two Envelope Bidding Procedure/Process as per the following:</p> <p>I. <u>Packet-I of Envelope -I (Techno-Commercial Bid)</u></p> <p>A. Shall contain Hard Copy of the following documents:</p> <p style="padding-left: 40px;"><i>a. Fee towards cost of RfP Documents as per clause ITB 1.4 or documentary evidence in support of exemption of Document Fee. Bidders submitting Document Fee through RTGS shall upload the scan copy of receipt of transfer of amount in Packet-I of Envelope-I. Participation of bidder shall be subject to confirmation of amount transferred through RTGS. The details mentioned in document uploaded as proof of transfer of amount shall only be considered for verification purpose. For Submission of Bid document fee through NEFT/RTGS mode, clause no - 1.4 of ITB (Section-2)/BDS (Section-IV Part-A) may also be referred (submission of Hard Copy in "Original" for Document Fee and "Copy" for documentary proof in support of exemption or Payment Acknowledgement towards Document Fee in case of Online Payment)</i></p> <p style="padding-left: 40px;"><i>b. Bid Security/ Earnest Money Deposit (EMD) (in Original) should be as per the format attached in Attachment-2 of Section-6 or documentary evidence in support of exemption of Bid Security, in separate envelope in accordance with clause 2.4 of ITB (submission of Hard Copy in "Original" for Bid Security and "Copy" of documentary proof in support of exemption)</i></p> <p>Note: In case MSE bidders are exempted from submission of Document fee & Bid Security as indicated in Clause No 2.4 of ITB Section- 2, then bidder has to submit copy of valid 'Udyam Registration Certificate' in Packet-1 of Envelope-1 for the purpose of Evaluation.</p>

Sl. No.	ITB Clause Ref. No.	Bid Data Details
		<p>Micro and Small Enterprises (MSEs) registered with Udyam Registration Portal as specified by Ministry of Micro, Small and Medium Enterprises are exempted from submission of fee towards the cost of Bidding Documents as per the Provisions of the Public Procurement Policy for Micro and Small Enterprises (MSEs) order 2012, Notification dated 01/06/2020 and 26/06/2020 read in conjunction with related notifications issued from time to time for such enterprises.</p> <p>The details of EMD and Tender Documents fee instrument have to be submitted in relevant field/column of online module.</p> <p>Tenders without EMD will be out rightly rejected. It should be ensured by the vendor that the original instrument of Bid Security/EMD is received by EESL before deadline of submission of techno-commercial bids.</p> <p>EESL shall not be responsible for any delay, loss or non-receipt of Tender Document Cost sent by post/courier. The instrument should reach in original to EESL office before the Bid Opening date. In case of Bidder's failure to submit the tender document cost/ tender fees (instrument in original hard copy) along with the Bid or subsequently pursuant to ITB Sub-clause 4.2, the Bid shall be rejected.</p> <p>Tender Documents fee is non-refundable. The bid securities of unsuccessful bidder(s) will be returned as promptly as possible after the award is made. The bid security of the successful Bidder will be returned when it has signed the contract agreement and has furnished the required performance security.</p> <p>B. Packet-II of Envelope -I shall contain Soft Copy (Scanned Copy) of the following documents:</p> <ol style="list-style-type: none"> 1. Declaration of Package as per format attached as Attachment - X of Section-6, Forms & Procedures. 2. Bid Form as per format attached as Attachment-1 of Section - 6, Forms & Procedures. <p>Note: In case of non-submission of this Bid form, bid will be rejected.</p> <ol style="list-style-type: none"> 3. A power of attorney duly authorized by a notary public, indicating that the person(s) signing the bid has/have the authority to sign the bid and thus the bid is binding upon the bidder during the full period of its validity in accordance with ITB clause 2.10. The said power of attorney to be submitted as Attachment-3 of Section-6, Bidders to use their own format. 4. Certificate regarding acceptance of important terms and conditions in line with ITB clause 4.6 as per format attached as Attachment-4 of Section-6, Forms & Procedure. 5. Deviation statement as per Attachment-5 of Section-6, Forms & Procedure.

Sl. No.	ITB Clause Ref. No.	Bid Data Details
		<p>NOTE:</p> <ol style="list-style-type: none"> a. Bids containing material deviations from or reservation to the terms and conditions and specifications mentioned in the RfP Documents will be treated as non-responsive and will not be considered further. b. In case of non-submission of this Attachment, the bid shall be considered as no deviation bid. <ol style="list-style-type: none"> 6. Form of acceptance of EESL fraud prevention policy and declaration as per Attachment- 6 of Section-6, Forms & Procedure. 7. Letter of undertaking (as per Attachment-7 of Section-6) to be executed by the Holding Company Supported by Board Resolution and submitted by the Bidder along with the Bid, in case financial support is being extended by the Holding Company to the Bidder for meeting the stipulated Financial Qualifying (as applicable) 8. NEFT/RTGS Bank details as per Attachment-8 of Section-6, Forms & Procedure. 9. Compliance of Matrix/checklist for technical and Financial QR duly filled and signed on Company letter head pad with company's seal. (Scanned Copy to be uploaded at E-tendering portal as per Attachment-9 of Section-6.) 10. Certificate Regarding Declaration of Local Content from participating bidder and from statutory auditor or cost auditor of the company (in the case of companies) or from a practicing cost accountant or practicing chartered accountant (in respect of suppliers other than companies) as per Attachment- 10 of Section-6. 11. Certification by the Bidder for "Restrictions on procurement from a Bidder of a country which shares a land border with India" as per order no. F.No.6/18/2019-PPD dated 23/07/2020 issued by Public Procurement Division, Department of Expenditure, Ministry of Finance, Government of India (DoE Order) (as per format in Attachment -11 of Section-6). 12. Details regarding Qualifying Requirement / Eligibility criteria as per Attachment-12 of Section-6. 13. Certificate regarding non- debarment for false declaration of Local Content as per Attachment-13 of Section-6. 14. Certificate regarding non-debarment / blacklisting/ disqualification as per Attachment-14 of Section-6. 15. Techno-commercial bid as indicated in bid document. Documentary evidence regarding bidder's qualifications to perform the contract as required in Qualifying Requirement (QR). 16. Any other document as considered appropriate <p>Note: The format for all the aforementioned Attachments are part of Section-6.</p>

Sl. No.	ITB Clause Ref. No.	Bid Data Details												
		<p><i>Bidder to note that no document revealing the prices shall be submitted in Envelop-1 along with the techno-commercial bid. Revealing of prices at this juncture in any mode shall lead to outright rejection of bid. Prices are to be filled in electronically in Envelop-2 as per the provision(s) made available by EESL in the prescribed format uploaded on e-procurement portal.</i></p> <p><u>II. Envelope-II (Second Envelope) shall contain Price Bid (to be filled-up online)</u></p> <p>The prices are to be filled in prescribed format in soft copy (in excel format) available on e-portal only. Bidders are requested not to submit the price bid in hard copy at EESL as the same shall not be considered. Price Bid Format as attached at Annexure-III in the RfP document is only for illustration/reference purpose, however, terms and conditions mentioned there in is part of this RfP/ Bidding documents.</p> <p>The price quoted in respect of all items in the above schedule shall be excluding GST. The Bidder shall quote its prices taking into account the Input Tax Credit (ITC) as may be available under the Goods and Services Tax (GST) Laws and Regulations.</p>												
7.	ITB 2.4	<p>Supplement ITB 2.4 with the following:</p> <p>Bid Security/EMD cluster wise detail is mentioned below:</p> <table border="1"> <thead> <tr> <th>Sl. No.</th> <th>Name of the Package</th> <th>Amount (in Rs.)</th> </tr> </thead> <tbody> <tr> <td>1.</td> <td>Package - 1</td> <td>13,73,000.00</td> </tr> <tr> <td>2.</td> <td>Package - 2</td> <td>16,65,000.00</td> </tr> <tr> <td></td> <td>Total (in Rs.)</td> <td>30,38,000.00</td> </tr> </tbody> </table> <p>Bidder has to submit EMD as per above table</p>	Sl. No.	Name of the Package	Amount (in Rs.)	1.	Package - 1	13,73,000.00	2.	Package - 2	16,65,000.00		Total (in Rs.)	30,38,000.00
Sl. No.	Name of the Package	Amount (in Rs.)												
1.	Package - 1	13,73,000.00												
2.	Package - 2	16,65,000.00												
	Total (in Rs.)	30,38,000.00												
8.	ITB 2.8	<p>Supplement ITB 2.8 with the following:</p> <ol style="list-style-type: none"> 1. The bidder at his own discretion can quote. 2. The bidder has to quote for all the line items for the Respective Project 												
9.	ITB 2.16	<p>Replace ITB 2.16 with the following:</p> <p>Consortium or Joint Venture is not allowed for the subject tender</p>												
10.	ITB 3.2	<p>Supplement ITB 3.2 with the following:</p> <p>Soft copy</p>												

Sl. No.	ITB Clause Ref. No.	Bid Data Details
		<p>part of the bid shall be uploaded through the portal www.tenderwizard.com/EESL at or before the submission time and date as stipulated in the RFP document. Hard copy of the bid under Packet-I to Envelope-1 as per ITB 2.1 must be received by the Employer at the address specified below no later than the time and date stated herein below:</p> <p>Address in Person or by Post: Additional General Manager (Contracts), M/s. Energy Efficiency Services Limited Buddha Bhawan, 3rd Floor, North block, MG Road Ranigunj, Secunderabad-500003, Telangana</p> <p>Deadline for submission of Hard copy of Documents Date: 24/10/2024</p> <p>Time: up to 11:00 hours [Indian Standard Time (e-procurementserver time)]</p> <p>Address for Bid Opening:</p> <p>M/s. Energy Efficiency Services Limited Buddha Bhawan, 3rd Floor, North block, MG Road Ranigunj, Secunderabad-500003, Telangana</p> <p>The deadline for <u>Soft copy part of the bid</u> submission is Date: 24/10/2024</p> <p>Time: 1100 hrs. [Indian Standard Time (e-procurement server time)].</p> <p>Bid submission timelines will be defined as per the e-Procurementserver clock only.</p> <p>Time and date for Bid Opening - Envelop-I (First Envelope): Date: 24/10/2024</p> <p>Time: 11:30 hours (Indian Standard Time)</p> <p>(a) Bid Title: <i>Name of the Tender - "Refurbishment and Repair & Maintenance of CCMS along with comprehensive on-site warranty (including supply of spares parts) for a period until the project completion of respective ULB in Street lighting project in the state of Telangana."</i></p> <p><i>NIT No. - EESL/06/24-25/SERC-Contracts/TS/CCMS -GHMC & ULB/OTE-232414,</i> Date: 25/09/2024</p>

Sl. No.	ITB Clause Ref. No.	Bid Data Details
		<p><u>Envelope-I (First Envelope)</u></p> <p>Do not open before 1130 hours (Indian Standard Time) on xx/xx/2024.</p> <p>In the event of the specified date for the submission of bids being declared a holiday for the Employer, the bids will be received/uploaded up to the appointed time on the next working day.</p> <p>Notwithstanding above, the Employer may, at its discretion, extend the deadline for submission of soft part of the bids from 1100 hrs (IST) to 1500 hrs (IST) on the same day in case the bidder(s) faces difficulty in submission of bids on the e-Procurement portal even for reasons not attributable to the e-Procurement server. In such a case, the bidder(s) shall however, be required to send a written communication on the e-mail IDs mentioned below for the purpose before the deadline for submission of soft part of the bids i.e. 1100 hrs. (IST) on the last day of the aforesaid deadline. Any request received by the Employer thereafter i.e. beyond 1100 hrs. (IST) or received prior to the day of deadline for submission of soft part of the bids shall not be entertained under any circumstances. The time of receipt of such communication on the e-mail IDs mentioned below shall govern for the purpose of determining whether or not the communication has been received prior to the deadline for bid submission as stipulated. The bidder(s) may also note that the above recourse shall, however, be adopted only once in the first such instance and no further extension on this account beyond 1500 hrs (IST) as above shall be given by the Employer.</p> <p>The e-mail IDs for aforesaid purpose are mentioned below: Email IDs:</p> <p>Primary - asrao@eesl.co.in Secondary - esrinivas@eesl.co.in</p>
11.	ITB 4.2	<p>Supplement ITB 4.2 with the following:</p> <p>During bid evaluation, the Employer may, at its discretion, ask the Bidder for a clarification of its bid. In case of erroneous/non-submission of following documents (as applicable):</p> <p>i) Online Payment Acknowledgement towards the Bid Document fee (<i>applicable only in cases where online Payment towards Bid Document fee is paid, prior to deadline for submission of bids</i>). Further, if Bidder has uploaded scanned copy of Banker's Cheque/ Demand Draft drawn in favour of "Energy Efficiency Services Limited" payable at New Delhi towards Bid Document fee, however, not submitted the original (in hard) along with the bid, then such Banker's Cheque/ Demand Draft shall be asked through clarification.</p>

Sl. No.	ITB Clause Ref. No.	Bid Data Details
		<p>ii) MSE certificate for the Tendered item / valid NSIC Certificate with the mention of Tendered item in the certificate. The issuance date for aforesaid certificates must be prior to deadline for submission of bids</p> <p>iii) Power of Attorney (POA) to sign the bid</p> <p>iv) Form of acceptance of EESL fraud prevention policy and declaration v) (as per format in Section 6, Forms & Procedure)</p> <p>vi) NEFT/RTGS Bank details (as per format in Section 6, Forms & Procedure)</p> <p>vii) Self-Declaration for not been blacklisted by Central/State/UT Government or any Public sector entities duly signed and stamped at company's Letter Head</p> <p>viii) Compliance of Matrix/checklist for bidder (as per format in Section 6, Forms & Procedure) duly filled and signed on Company letter head pad with company's seal</p> <p>ix) Certificate regarding Declaration of local content (as per format in Section 6, Forms & Procedure)</p> <p>x) Self-Declaration duly signed on Company Letter Head Pad with company's seal for not being under debar list/undergoing debarment period on account of breach of the code of integrity under rule 175(1)(i)(h) of general financial rules for giving false declaration of local content</p> <p>xi) Declaration regarding "Restrictions on procurement from a Bidder of a country which shares a land border with India"</p> <p>xii) Consortium Agreement (if applicable)</p> <p>xiii) Other documents/details of historical nature such as certificate of incorporation, complete Audited Annual Reports together with Audited statement of accounts, Experience Certificate issued by Utility/Employer for work completed/executed prior to deadline for submission of bids etc.</p> <p>xiv) Any other documents/details/information of historical nature.</p> <p>The EESL may give the Bidder not more than 5 working days' notice to rectify/furnish such documents, failing which the bid shall be rejected. The request for clarification and the response shall be in writing, and no change in the price or substance of the bid shall be sought, offered or permitted.</p>

Sl. No.	ITB Clause Ref. No.	Bid Data Details
12.	ITB 4.7 & 4.8	<p>Supplement ITB 4.7 & 4.8 with the following:</p> <p>Tender will be evaluated on L1 basis. Techno-commercially suitable bidder having the lowest total price shall be L-1.</p>
13.	ITB 4.5	<p>Supplement ITB 4.5 with the following:</p> <p>The Employer may waive any minor informality, nonconformity or irregularity in a bid that does not constitute a material deviation, whether or not identified by the Bidder in relevant Attachment to its bid, and that does not prejudice or affect the relative ranking of any Bidder as a result of the technical and commercial evaluation, pursuant to ITB Clause 4.7 & 4.8.</p>
14.	ITB 4.6	<p>Adding new clause as ITB 4.6.1 with the following:</p> <p>Qualification:</p> <p>The Employer will ascertain to its satisfaction whether Bidders determined having submitted substantially responsive bids are qualified, as per the Qualification Requirement specified in Part- B of Section-4 to satisfactorily perform the contract. The Employer shall be the sole judge in this regard and the Employer's interpretation of the Qualification Requirement shall be final and binding.</p> <p>The determination will take into account the Bidder's financial, technical capabilities including production capabilities, in particular the Bidder's contract work in hand, future commitments & current litigation and past performance including fatal accidents during execution of contracts that have been awarded by the Employer on the Bidder. It will be based upon an examination of the documentary evidence of the Bidder's qualifications submitted by the Bidder in the bid, as well as such other information as the Employer deems necessary and appropriate. This shall, however, be subject to assessment that may be carried out, if required, by the Employer.</p> <p>The Employer may waive any minor informality, nonconformity or irregularity in a bid that does not constitute a material deviation, affecting the capability of the Bidder to perform the Contract. An affirmative determination will be a prerequisite for the Employer to evaluate the Techno - Commercial Part and open the Second Envelope of the Bidder. A negative determination will result in rejection of the Bidder's bid.</p>
15.	ITB 4.9	<p>Supplementing ITB 4.9 with the following:</p> <p>Regarding deviations, conditionality or reservations introduced in the bid, which will be reviewed to conduct a determination of substantial responsiveness of the Bidder's bid as stated in ITB Clause 4.9, the order of precedence of these documents to address contradictions, if any, in the contents of the bid, shall be as follows:</p> <p>I. Letter of Bid (Bid Form).</p>

Sl. No.	ITB Clause Ref. No.	Bid Data Details
		<p>II. Attachment-5 (Deviation Statement) III. Price Schedules IV. Technical Documents V. Any other part of the bid</p> <p>Contents of the document at Sr. No. I above will have overriding precedence over other documents (Sr. No. II to V above). Similarly, contents of document at Sr. No. II above will have overriding precedence over other documents (Sr. No. III to V above), and so on. However, any major inconsistency amongst the above documents of the bid will be interpreted against the bidder.</p>
16.	ITB 5.9	<p>New Clause ITB 5.9 Added As</p> <p>Withholding of Bidder: In case of failure to honour its bid after emerging as successful bidder, the bidder will be withhold from participating in EESL's tenders for a period of one year from the date of communication of such withholding to the bidder. During this tenure, the bidder will be barred from participation in EESL tendering process. However, bidder has to continue the unexecuted work of the other prevailing work if any under the current running contracts. Simultaneously, the EMD submitted by such bidder against the subject tender will be forfeited. If bidder is exempted from submission of EMD, then the EMD amount will be adjusted from the payments due to the contractor against other running contracts. If there is no running contract of the bidder/ no payment dues of the bidder then EESL reserves the right to take any legal remedy as deemed fit to recover the penalty equivalent to EMD amount through legal means.</p>

----- End of Part-A (BDS) -----

Section - 4

Part-B (QR)

Eligibility and Qualifying Requirements (QR)

A. Eligibility Criteria:

S. No.	Eligibility Criteria	Documents to be Submitted for Compliance by the Bidders
1.	<p>Bidder should be a Single Entity means a limited company (as defined in the Companies Act, 1956 and any amendment thereof)</p> <p>OR</p> <p>A registered partnership firm (registered under section 59 of the Partnership Act, 1932 and any amendment thereof)</p> <p>OR</p> <p>A limited liability partnership (under the Limited Liability Partnership Act, 2008 and any amendment thereof)</p> <p>(Consortium/JV is not allowed in the tender)</p>	<p>Copy of certificate of incorporation/ Memorandum of Association/Article of Association</p> <p>OR</p> <p>A registered Partnership Deed</p> <p>OR</p> <p>LLP registration certificate issued by registrar of Companies</p> <p>OR</p> <p>In Case of Proprietor GST Registration and PAN Card Copy is to be submitted.</p>
2.	<p>PPP MII guidelines issued by Govt. of India shall be applicable for this tender. Only Class-I Local Suppliers with 50% minimum local content are eligible to bid in this tender in conformance with the order for "Public procurement (Preference to make in India) to provide for Purchase preference (linked with local content in respect of Power sector" issued vide ref no. A-1/2021-FSC-Part (5) GoI, MOP Dated 16.11.2021</p> <p>NOTE: - Only Class-I local suppliers as defined in the above tender are eligible to take part in this bidding process.</p>	<p>The Bidder shall give a self-certification in his bid in the enclosed format, indicating the percentage of Local Content and certifying that the item offered meets the Local Content requirement for 'Class -I local supplier' and shall give details of the location(s) at which value addition is made.</p> <p>Further, in case of tenders above Rs. 10 Cr, the 'Class-I local supplier' shall provide a certificate from statutory auditor or cost auditor of the company (in the case of companies) or from a practicing cost accountant or practicing chartered accountant (in respect of suppliers other than companies) giving the percentage of Local Content as per the format in the RfP Documents</p>
3.	<p>Pursuant to Order No. F. No 6/18/2019-PPD dated-23-July-2020 from Department of Expenditure, Ministry of Finance, the applicant should be either of the following:</p> <ul style="list-style-type: none"> · Not from a country which shares a land border with India <p>OR</p> <ul style="list-style-type: none"> · Applicant from a country which shares a land border with India and registered with Competent Authority in accordance with order mentioned above. 	<p>Bidder to submit a Declaration as per the format enclosed in this RfP Documents.</p>

S. No.	Eligibility Criteria	Documents to be Submitted for Compliance by the Bidders
	The definition of "Bidder" from a country which shares a land border with India shall be as in paragraph 8 of the above mentioned order. Further, all the guidelines mentioned to this above order shall be applicable to this Tender. Bidder shall carefully go through the same and ensure its eligibility as per the said order.	
4.	Not to be blacklisted by Central/ State/ UT Government or any Public sector entities for the tender item/ work duly signed and stamped at company's Letter Head.	To submit Self Declaration on Company's Letter Head.

B. Qualifying Requirements:

S. No.	Qualifying Requirements	Documents to be Submitted for Compliance by the Bidders																														
1.	<p>QUALIFICATION OF THE BIDDER</p> <p>Qualification of bidder will be based on meeting the minimum pass/ fail criteria specified below regarding the Bidder's Technical Experience and Financial QR as demonstrated by the Bidder's responses in its Bid.</p> <p>Subcontractors' technical experience and financial resources shall not be taken into account in determining the Bidder's compliance with the qualifying criteria. The bid can be submitted by an individual firm only (i.e., Sole bidder). Consortium/JV not allowed.</p>																															
1.1	<p>Technical Experience</p>																															
1.1.1	<p>Bidder should be an Original Equipment Manufacturer (OEM) of <i>Centralized Control & Monitoring System (CCMS) equipment/ Electricity distribution & control apparatus/ group controller equipment</i> and should have successfully executed/ completed 'Similar work' in the last 3 years, as on the originally scheduled date of bid opening (i.e., date of bid opening as per NIT) in DISCOMS (both private &/or Government Distribution Company)/ Government Department/ Public Sector Undertaking (PSU)/ Urban Local Body (ULB) /any other Govt. Organization .</p> <p>For Package-1 (GHMC):</p> <table border="1"> <thead> <tr> <th>S. No.</th> <th>Package-1</th> <th>Work Order Value in Rs.</th> </tr> </thead> <tbody> <tr> <td>1.</td> <td>Single Work Order of</td> <td>5,49,18,642.94</td> </tr> <tr> <td>2.</td> <td>Two Work orders each of</td> <td>3,43,24,151.84</td> </tr> <tr> <td>3.</td> <td>Three Work orders each of</td> <td>2,74,59,321.47</td> </tr> <tr> <td></td> <td>Total</td> <td>11,67,02,116.26</td> </tr> </tbody> </table> <p>For Package-2 (ULBs across Telangana):</p> <table border="1"> <thead> <tr> <th>S. No.</th> <th>Package-2</th> <th>Work Order Value in Rs.</th> </tr> </thead> <tbody> <tr> <td>1.</td> <td>Single Work Order of</td> <td>1,66,47,809.66</td> </tr> <tr> <td>2.</td> <td>Two Work orders each of</td> <td>1,04,04,881.04</td> </tr> <tr> <td>3.</td> <td>Three Work orders each of</td> <td>83,23,904.83</td> </tr> <tr> <td></td> <td>Total</td> <td>3,53,76,595.54</td> </tr> </tbody> </table> <p>If the bidder is participating for one package, then he has to consider the work orders of that particular package.</p>	S. No.	Package-1	Work Order Value in Rs.	1.	Single Work Order of	5,49,18,642.94	2.	Two Work orders each of	3,43,24,151.84	3.	Three Work orders each of	2,74,59,321.47		Total	11,67,02,116.26	S. No.	Package-2	Work Order Value in Rs.	1.	Single Work Order of	1,66,47,809.66	2.	Two Work orders each of	1,04,04,881.04	3.	Three Work orders each of	83,23,904.83		Total	3,53,76,595.54	<p>Bidder should provide self-certification on company's Letter Head that they are Manufacturer of Centralized Control & Monitoring System (CCMS) equipment/ Electricity distribution & control apparatus/ group controller equipment.</p> <p>Also, bidder should submit an excise Registration Document/ GST Registration Document/ ISO Certificate/ Company Registration/ MSME Registration certificate (issued as manufacturer)/ any other document which shows that the bidder is a manufacturer of <i>Centralized Control & Monitoring System (CCMS) equipment/ Electricity distribution & control apparatus/ group controller equipment</i>. Documentary evidence shall be furnished along with the bid.</p> <p>Further, Documentary evidence should also be submitted in the form of copies of relevant work orders/ contract agreements/ purchase orders/ LOAs/ LOIs along with copies of any document in respect of satisfactory execution/ completion of each of those purchase orders/ work orders/ contract agreements/ LOAs/ LOIs such as</p> <p>(i) *Successful completion certificate/s</p> <p>(OR)</p>
S. No.	Package-1	Work Order Value in Rs.																														
1.	Single Work Order of	5,49,18,642.94																														
2.	Two Work orders each of	3,43,24,151.84																														
3.	Three Work orders each of	2,74,59,321.47																														
	Total	11,67,02,116.26																														
S. No.	Package-2	Work Order Value in Rs.																														
1.	Single Work Order of	1,66,47,809.66																														
2.	Two Work orders each of	1,04,04,881.04																														
3.	Three Work orders each of	83,23,904.83																														
	Total	3,53,76,595.54																														

S. No.	Qualifying Requirements	Documents to be Submitted for Compliance by the Bidders
	<p>If the bidder is participating for all the packages, then he has to consider the total of the work orders for all the packages.</p> <p>“Similar Work” means SITC work of web enabled Smart meter based Street light controllers (SMSLC/CCMS) OR SITC work of web enabled RTU & static meter based Street light controller OR SITC work of any other web enabled Street light group controller equipment</p> <p>The work “executed” mentioned above means the bidder should have achieved the criteria specified above even if the total contract is started earlier and/or is not completed/ closed. However, the work executed /completed must include “Similar work” as above.</p> <p>In case of orders under execution, the value of work executed as on the originally scheduled date of bid opening (i.e., date of bid opening as per NIT) as certified by the Client shall be considered. However, the work executed must include “Similar work” as above.</p>	<p>(ii) Any other documentary evidences that can substantiate the successful execution of each of the purchase orders/ work orders/ contract agreements/ LOAs/ LOIs submitted.</p> <p>Work orders along with its evidence for successful completion / execution from DISCOMS (private &/or Government Distribution Company)/ Government Department/ Public Sector Undertaking (PSU)/ Urban Local Body (ULB)/ any other Govt. Organization shall only be considered for evaluation.</p> <p><i>*Successful means certificate issued by the client without any adverse remarks.</i></p>

1.2 Financial QR:

1.2.1	<p>Bidders should have an Average Annual Turnover (ATO) during the last 3 Financial Years as below.</p> <table border="1" data-bbox="289 1314 821 1495"> <thead> <tr> <th>S. No.</th> <th>Package</th> <th>ATO Value in Rs.</th> </tr> </thead> <tbody> <tr> <td>1.</td> <td>Package - 1</td> <td>2,05,94,491.10</td> </tr> <tr> <td>2.</td> <td>Package - 2</td> <td>62,42,928.62</td> </tr> <tr> <td></td> <td>Total</td> <td>2,68,37,419.73</td> </tr> </tbody> </table> <p>If the bidder is participating for one package, then he has to consider the ATO of that particular package.</p> <p>If the bidder is participating for all the packages, then he has to consider the total of the ATOs for all the packages.</p> <p>Note:</p>	S. No.	Package	ATO Value in Rs.	1.	Package - 1	2,05,94,491.10	2.	Package - 2	62,42,928.62		Total	2,68,37,419.73	<p>Duly authorized copies of audited financials for preceding last three Financial Years are to be submitted by the bidder.</p> <p>ATO means revenue from operations.</p>
S. No.	Package	ATO Value in Rs.												
1.	Package - 1	2,05,94,491.10												
2.	Package - 2	62,42,928.62												
	Total	2,68,37,419.73												

S. No.	Qualifying Requirements	Documents to be Submitted for Compliance by the Bidders																								
	<p>It may be noted that existence of Bidder for 1 FY will suffice the purpose. Accordingly, for calculation of ATO, the audited financial figures as available shall be considered, however, in case of ATO for less than 3 years the financial figures for available years shall be averaged out for 3 years (i.e., total available Turnover shall be divided by 3) for Financial QR compliance.</p>																									
1.2.2	<p>Bidder shall have liquid assets (LA) or/ and evidence of access to or availability of credit facilities of not less than Rs. 223.64 Lakhs.</p> <table border="1" data-bbox="289 657 820 835"> <thead> <tr> <th>S. No.</th> <th>Package</th> <th>LA Value in Rs.</th> </tr> </thead> <tbody> <tr> <td>1.</td> <td>Package - 1</td> <td>1,71,62,075.93</td> </tr> <tr> <td>2.</td> <td>Package - 2</td> <td>52,02,440.52</td> </tr> <tr> <td></td> <td>Total</td> <td>2,23,64,516.44</td> </tr> </tbody> </table> <p>If the bidder is participating for one package, then he has to consider the LA of that particular package.</p> <p>If the bidder is participating for all the packages, then he has to consider the total of the LAs for all the packages.</p> <p>(Balance Sheet of immediate last financial year would be considered for this calculation.)</p> <p>Note: The LA for the bidder shall be calculated from the Audited Financial Statement as per the following:</p> <p>LA= [Current Assets- Inventory]</p>	S. No.	Package	LA Value in Rs.	1.	Package - 1	1,71,62,075.93	2.	Package - 2	52,02,440.52		Total	2,23,64,516.44	<p>Duly authorized copy of audited financials for preceding last Financial Year is to be submitted by bidder. (Balance Sheet of immediate last financial year would be considered for this calculation.)</p> <p>OR</p> <p>Certification from Bank regarding availability of credit facilities of not less than Rs. 223.64 Lakhs.</p> <table border="1" data-bbox="922 919 1435 1098"> <thead> <tr> <th>S. No.</th> <th>Package</th> <th>LA Value in Rs.</th> </tr> </thead> <tbody> <tr> <td>1.</td> <td>Package - 1</td> <td>1,71,62,075.93</td> </tr> <tr> <td>2.</td> <td>Package - 2</td> <td>52,02,440.52</td> </tr> <tr> <td></td> <td>Total</td> <td>2,23,64,516.44</td> </tr> </tbody> </table> <p>If the bidder is participating for one package, then he has to consider the LA of that particular package.</p> <p>If the bidder is participating for all the packages, then he has to consider the total of the LAs for all the packages.</p> <p>(such certificates should have been issued not earlier than three months prior to the date of originally scheduled date of bid opening as per NIT). Format of the certificate is enclosed in the RfP Document.</p>	S. No.	Package	LA Value in Rs.	1.	Package - 1	1,71,62,075.93	2.	Package - 2	52,02,440.52		Total	2,23,64,516.44
S. No.	Package	LA Value in Rs.																								
1.	Package - 1	1,71,62,075.93																								
2.	Package - 2	52,02,440.52																								
	Total	2,23,64,516.44																								
S. No.	Package	LA Value in Rs.																								
1.	Package - 1	1,71,62,075.93																								
2.	Package - 2	52,02,440.52																								
	Total	2,23,64,516.44																								
1.2.3	<p>The net worth of the bidder in immediate last financial year should not be less than 100% of paid-up share capital or capital.</p> <p><i>Additionally, in case of Partnership/ Proprietorship, Net worth may be considered negative in case closing capital of immediately preceding year is less than average closing capital of previous 3 financial years including immediate preceding year.</i></p>	<p>Duly authorized copies of audited financials for preceding last three Financial Years are to be submitted by bidder.</p>																								

S. No.	Qualifying Requirements	Documents to be Submitted for Compliance by the Bidders
	<p>Note: It may be noted that existence of Bidder for 1 FY will suffice the purpose. Accordingly, for calculation of Net worth the audited financial figures as available shall be considered. (e.g., for considering net-worth calculations, if bidder is in existence for 2 Years' and Audited Financial Statements for both years are available then average of 2 years shall be considered. Similarly, if only one-year's Audited Financial Statements is available, the same will be considered for net-worth calculations). Same Philosophy shall be applicable for partnership firms also.</p>	

Notes to the QR:

Sl. No.	
1.	<p>Financial QR: The Bidder shall also furnish documentary evidence/ declaration regarding Financial restructuring of the company, if any. If the opening of the bids or the ascertainment of qualification is carried out after 30th September, the bidder shall be required to submit the complete annual reports together with Audited statement of accounts of the company for the immediately preceding Financial Year except in cases where the Board of the Company/ Registrar of Companies has granted extension of time for finalization of accounts, for which the bidder has to submit requisite documentary evidence. In case of Bidder's failure to submit the same along with the Bid or subsequently pursuant to Clarification, the Bid shall be rejected.</p> <p><i>In case of proprietorship/ partnership (as applicable as per sl.no-1 of Eligibility Criteria), ITR along with management signed accounts to be submitted, if audit is not required.</i></p> <p><i>In case of Proprietor / Partnership firm, where auditing of Balance Sheet is not required, the date of ITR (if extended) to be considered. Proof of extension from the Income Tax Department to be submitted by the bidder.</i></p>
2.	<p>For Start-up firms as per Gazette Notifications dated 17-Feb-2016, G.S.R. 180 (E) and MSEs, relaxation will be given in this tender as per Clause No. 2.4 of Section-2 of this tender.</p>
3.	<p><u>In case of holding company:</u> - The holding subsidiary relationship should be in existence for at least one year as on the date of submission of the bids.</p> <ul style="list-style-type: none"> • "In case bidder is not able to furnish its audited financial statements on standalone entity basis, the unaudited unconsolidated financial statements of the bidder can be considered acceptable provided the bidder furnishes the following further documents on substantiation of its qualification:

Sl. No.	
	<ul style="list-style-type: none"> • Copies of the unaudited unconsolidated financial statements of the Bidder along with copies of the audited consolidated financial statements of the Holding Company with a letter of undertaking from holding company supported by Board pledging unconditional and financial support. Irrevocable in the format enclosed in Attachemnt-9 of Section-6, Forms & Procedures. • A certificate from the CEO/CFO of the holding company, stating that the unaudited consolidated financial statements from part of the Consolidated Annual Report of the Company. • In case a bidder does not satisfy the financial criteria, the holding company would be required to meet the stipulated turn over requirements, provided that the net worth of such holding company as on the last day of the preceding financial year is at least equal to or more than the paid-up share capital of the holding company. In such an event, the bidder would be required to furnish along with its bid, a letter of Undertaking from the holding company, supported by the Board Resolution, as per the format enclosed in the bid documents (Attachemnt-9 of Section-6, Forms & Procedures), pledging unconditional and irrevocable financial support for the execution of the Contract by the bidders in case of award. • In case the Bidder meets the requirement of Net worth based on the strength of its Subsidiary(ies) and/or Holding Company and/or Subsidiaries of its Holding Companies wherever applicable, the Net worth of the Bidder and its Subsidiary(ies) and/or Holding Company and/or Subsidiary(ies) of the Holding Company, in combined manner should not be less than 100% of their total paid up share capital. However individually, their Net worth should not be less than 75% of their respective paid up share capitals.” • The supporting documents in support of above Qualification Requirement should be submitted along with tender document, otherwise Techno-commercial offer submitted by the bidder is liable to be considered as non-responsive. • All the required documents must be properly annexed and submitted as mentioned above with necessary details in brief

----- End of Part-B (BDS) -----

Section - 4 Part- C

Technical Specifications

Technical Specifications

1. Title

“Refurbishment and Repair & Maintenance of CCMS along with comprehensive on-site warranty (including supply of spares parts) for a period until the project completion of respective ULB in Street lighting project in the state of Telangana”.

2. Completion Period

S. No.	Activity	Completion Period
1.	Refurbishment and Repair & Maintenance of CCMS along with comprehensive on-site warranty (including supply of spares parts)	The refurbishment work has to be completed within One (1) month from the date of issuance of LoA. The Repair and Maintenance along with comprehensive on-site warranty of CCMS will start from the completion of refurbishment period (i.e., 1 month) and continue until the project completion of the respective ULB.

3. Scope of work:

The brief scope of work essentially consists of following: -

3.1 Refurbishment and Repair & Maintenance of CCMS along with comprehensive on-site warranty (including supply of spares parts).

- 3.1.1 The survey is the most important aspect of the project; Successful Bidder has to do a detailed survey of the existing CCMS boxes to access the condition of the existing CCMS and to estimate the spares required for rectification/ refurbishment of existing CCMS to make it operational.
- 3.1.2 Successful Bidder shall arrange to provide all appropriate resources (such as manpower, testing instruments, vehicles etc.,) during the contract period.
- 3.1.3 Bidder has to repair/ refurbish/ replace the existing CCMS up to completion of the project (GHMC & ULBs) for the quantity as per BOQ. Bidder has to repair and maintain the CCMS in working conditions by replacing the spare parts at the site as well as replacement of old CCMS with new CCMS, if the existing CCMS is not repairable. The related cost shall be included in the Contract Price.
- 3.1.4 The technical specifications of the CCMS/ spares to be repaired/ refurbished/ supplied shall comply with the requirements given under Chapter “Technical Specifications”, which forms part of the subject Tender documents.
- 3.1.5 The Bidder shall supply the entire CCMS and/ or part components of the CCMS including other related items to their respective store/ depot during Project execution & maintenance.

- 3.1.6 Transportation, storage, Demurrage/Wharfage, etc.: Bidder has to supply, install & maintain the material at designated site as per the direction of EIC of the project. Storage, loading, packing Unloading etc. of material at project site is in scope of bidder. Transport to such place of destination in India including insurance, as shall be specified in the Contract, shall be arranged by the Successful Bidder and the related cost shall be included in the Contract Price.
- 3.1.7 Servicing warranty redemptions as well as providing CCMS spares like MCB, SPD, contactor/relay, power supply, set of connectors, tested PCBs, terminal block and other components and consumables items is in the scope of Successful bidder and the related cost shall be included in the Contract Price.
- 3.1.8 Successful Bidder has to maintain 5% spares as buffer stock (like MCB, SPD, contactor/relay, power supply, set of connectors, tested PCBs, terminal block) along with repair/ refurbishment of CCMS, which will be utilized during maintenance process. These 5% spares like MCB, SPD, contactor/relay, power supply, set of connectors, tested PCBs, terminal block shall not be counted towards payment to vendors from EESL and shall be considered as free of cost (FoC).
- 3.1.9 Selection of suitable items/parts in line with the Technical Specifications and required due diligence of capability and coordination testing of the product with each CCMS offered.
- 3.1.10 A Complaint Management System (web-based tool) to be established by the successful bidder for complaint lodging, monitoring, action, attending and closure of warranty redemption requests.
- 3.1.11 The CCMS door shall be properly locked, and the key shall be in the custody of maintenance in charge/EIC.
- 3.1.12 For connectivity of network and transferring data from each CCMS to portal, required SIM needs to be provided by the successful Bidder without any additional cost during the contract period.
- 3.1.13 CCMS portal needs to be developed by the Successful Bidder to maintain the database for streetlight & CCMS maintenance.
- 3.1.14 The Successful Bidders shall execute modification work whatsoever required in network or switching / metering panels for implementation of this project without any additional cost.
- 3.1.15 Any equipment/ machinery/ tools/ storage/ material or whatsoever required for the implementation of the project and to achieve the timelines/ benchmarks is in the scope of the Successful Bidder.
- 3.1.16 The Successful Bidder will be responsible for taking the Latitude and Longitude coordinates of each pole where CCMS is being installed and will update the same in the CCMS portal by Successful Bidder.
- 3.1.17 The successful Bidder/s has to intimate (i.e. through written communication) EIC about any case of power theft or unauthorized connection of load from street lighting network on priority basis.
- 3.1.18 The successful Bidder/s shall preferably set up at least one office cum site project store or make any other necessary suitable arrangement for storage of all supplied materials, spares, tools and equipment etc. required during the R&M works.

- 3.1.19 The repair/ refurbishment of CCMS may also include items such as nuts, bolts, lugs, glands, fittings, cable tie, connectors, silicon solution, other consumable items etc. which are in the scope of Successful Bidder.
- 3.1.20 The Successful Bidders will be responsible for transportation, packing, Loading & Unloading of Material (CCMS and related spares) from their stores to the site.
- 3.1.21 All failure due to mishandling, improper installation or improper infra maintenance, the replacement/repair of the defective materials on such account shall be in the scope of the Successful Bidder.
- 3.1.22 Any additional items installed which is not specified under this BID Document need an authorization from Client & EESL team to claim the same from client accordingly. These additional items payment to the successful bidder is linked with the additional items payment from client to EESL.
- 3.1.23 The Successful Bidders shall repair and maintain the CCMS i.e. cables, wires, pole boxes, MCB's / Fuses, earthing,switchgear etc. what so ever is required during the maintenance period
- 3.1.24 Once the Successful Bidders take over CCMS network, all responsibility of CCMS shall be in the Successful Bidder's scope to keep them healthy through proper maintenance.
- 3.1.25 The comprehensive maintenance contract covers all maintenance activity, any damage or malfunctioning of CCMS on account of storage, unauthorized handling etc. However, the R&M contract shall not be applicable for any damage in the CCMS or malfunctioning of CCMS due to any Act of God beyond the control of either of the Parties including earthquakes, heavy rains storms, tempest, whirlwinds, landslides, volcanic eruptions, fire or any calamities and riots on which supplier must have the insurance to claim the value accordingly.
- 3.1.26 During maintenance period, Successful Bidder shall be proactive in monitoring the CCMS regularly & perform preventive and corrective maintenance. In case, any pilferage or theft of energy/ material in the network of installed CCMS is observed, this shall promptly be reported to EESL & Client in writing.
- 3.1.27 The Successful Bidders shall be responsible for timely manual execution of switching ON & OFF of the streetlights in case of failure of remote operation of CCMS with written intimation to EIC.
- 3.1.28 The Successful Bidders will be solely responsible for CCMS functionality and legal proceedings on any account with respect to this project till the end of the Contract Period. Thereafter, the CCMS will be transferred to EESL's Client i.e., ULB in 100% functional condition except routine wear & tear and aging of execution without any further cost.
- 3.1.29 The Successful Bidders shall indemnify EESL from any losses on any account during the maintenance period after take over the street light network with CCMS till the handing over to authorized representative.

- 3.1.30 The Successful Bidders has to setup office cum maintenance center for each Client zone/ ULB with required skilled manpower, necessary spares like MCB, SPD, contactor/relay, power supply, set of connectors, tested PCBs, terminal block, vehicles, tools, machinery, sufficient storage space or what so ever is required, within jurisdictional area of project from where proper maintenance of CCMS for street light network will be ensured.
- 3.1.31 Providing SIM card, SIM recharge and maintaining/ ensuring seamless connectivity of network and transferring data from each CCMS to portal needs to be provided by the Successful Bidder without any additional cost.
- 3.1.32 Developed CCMS portal need to be maintained & managed by the Successful Bidder to have proper record/ database for CCMS maintenance.
- 3.1.33 Successful Bidder shall take complaints on CCMS every day on real time basis (on daily basis only) and will establish and provide efficient communication with cell phones/ wireless communication between various agencies to attend to CCMS complaints.
- 3.1.34 Complaint is to be resolved within 48 Hours from the time of receiving of Complaint by Successful Bidder.
- 3.1.35 Storage and security of the all the required material is totally in the scope of Successful Bidders. Successful Bidder shall make his own arrangement for watch & ward and safety of his men, material, vehicle etc. and nothing extra shall be paid by EESL on this account.
- 3.1.36 Maintenance of the complete CCMS control center and associated accessories to be done regularly is in the scope of the Successful Bidder.
- 3.1.37 In case of any losses arising due to CCMS infrastructure maintenance shall be in the scope of the successful Bidder.
- 3.1.38 Successful bidder shall ensure 98% service level through CCMS for lighting control Unit at any point of time during the defined contract period of R&M for the respective ULB/site.
- 3.1.39 Successful bidder shall ensure that service level data of CCMS has to show on CCMS Dashboard/ portal.
- 3.1.40 Quarterly ULB wise maintenance report of CCMS to be provided by the successful bidder. (i.e., complaint raised, resolved within 48 hrs., resolved after 48hrs, pending complaint by maintaining the 98% uptime of CCMS).
- 3.1.41 Comprehensive on-site warranty starts from the completion date of refurbishment/ replacement of CCMS and ends after completion of project period, or the period as defined in issued PO. However, the warranty will also cover the initial period of One (1) month being considered as the /refurbishment/replacement period of the Project.
- 3.1.42 A comprehensive onsite warranty shall be taken as per the requirement of EESL in confirmative with client agreement. Warranties for less than a year (i.e., fraction of a year) shall be adjusted pro - rata in terms of month.

- 3.1.43 The Successful Bidder will refill all the spares parts (MCB, SPD, contactor/relay, power supply, set of connectors, tested PCBs, terminal block) required in advance (at least 5% of each type of spares parts as defined above against supplied CCMS quantities) at each field/site to keep CCMS healthy through proper Repair & Maintenance for maintaining Street lights UP time 98 % as per the agreement with client.
- 3.1.44 The comprehensive warranty will cover warranty of complete equipment including but not limited to repair/ replacement of defective parts in part or whole, replacement of complete CCMS, supply of all maintenance spares, other critical components including mother board, energy meter, electronic controller comprising of wireless communications etc., and consumables (i.e., MCB, SPD, contactor/ relay, power supply, set of connectors, tested PCBs, terminal block) and maintenance/ upkeep and upgradation of software as required to make the equipment good and in working condition.
- 3.1.45 As SLA (98% uptime & rectification within 48 Hours) is to be attained all the time, successful bidder shall maintain/ replenish sufficient spares (equal to 5%) of each type of spares (which would be used as buffer stock) at respective site through-out the warranty period with no cost escalation for rectification of fault for speedy resolution of non-functioning CCMS.
- 3.1.46 In case of shortfall/ non-maintenance of the required minimum buffer stock quantity of spares beyond 50% the buffer stock and its replenishment beyond 10 days from the date of intimation from EESL, a notional penalty at the rate of Rs. 1,00,000 per month. For the period less than one month, beyond 10 days, same shall be calculated proportionality on pro-rata basis for actual number of days and shall be charged by EESL subject to a maximum of 5% of the total contract value from the payments due to bidder from the date when replenishment was supposed to be done till the actual date of replenishment.

4. Deployment of manpower and Provision of resources during contract period

Successful Bidder shall arrange to provide all appropriate resources (such as manpower, testing instruments, vehicles etc.) based on the requirement for the Repair and maintenance of CCMS, for contract period as per PO. Successful Bidder shall be held responsible for any delay in maintenance of CCMS due to non-availability of resources required etc.

Details for minimum requirement of field force and equipment (for the purpose of cost estimation for total package) are given below:

Particular	Minimum Requirement
Teams	<p>Every Successful Bidder must have a maintenance team, which comprises of at-least 01 technician having experience of maintaining CCMS in ULBs & 01 helper for up to 250 CCMS and part thereof (01 driver required additionally in case the maintenance team is having 4-wheeler or 3-wheeler).</p> <p>Successful Bidder to ensure a deployment of regular Staff: One Project Team comprising of:</p> <ul style="list-style-type: none"> • One Project Head with min. 8 years of experience in the relevant field (up to awarded quantity of CCMS for each state) • One Project Engineer with Electrical engineering background with minimum 02 years of experience dedicatedly for the project at each site. • The concerned Successful bidder shall be responsible for compliance all Labour deployed for above maintenance work; further Successful bidder (s) shall indemnify EESL as on in any compensation, injury arising out of any accident arising out of deployed for above contract. The Successful bidder shall indemnify any financial and legal arising out of Deployment of manpower in the above contract.
Supervisor	1 Supervisor per 5 Maintenance Teams or less, whichever is minimum
2 Wheelers	Successful Bidders should have minimum dedicated one (1) no. of two wheelers for upto 250 CCMS and part thereof available 24/7 & 365 days at their disposal for the project implementation period and maintenance for a period given in LoA.

5. Technical Specifications of CCMS for Single phase and three phase (in case replaced with New CCMS and spares wherever required)

5.1 Configuration: System with communication system and centralized control and monitoring (cluster / group control)

5.1.1 Features

5.1.1.1 Controller and Metering Unit

- Schedule the timing of lights (pre-programmed based on astronomical clock or on field or through central control)
- ON / OFF Switch (on field or centrally)
- CCMS System for Capture the energy usage and other parameters at pre-determined interval and store data for 30 days.
- Ability to connect with a communication device.
- Ability to download data in field.
- System protection against surges
- Ability to upgrade firmware remotely OTA or on field using a communication device.

5.1.1.2 Enclosure

- Enclosure should be made of fire-retardant FRS/SMC/Steel material and with impact resistance of IK10 & IP 65.

- The Enclosure shall be of 2.5mm thickness and must have sufficient space to facilitate access to terminals and other items during commissioning and maintenance.
- The single-phase model of CCMS shall have dimensions of 400 mm H x 300 mm W and 200 mm Depth.
- The 3-phase model shall have dimensions of 530 mm H x 450 mm W and 200 mm Depth.
- The enclosure must have a door constructed with rubber beadings constructed to give a water tight compartment.
- The enclosure must have a rectangular cut out with UV protected Poly Carbonate window cover to facilitate meter reading and for ambient light entry to the Photo sensor unit.
- The enclosure must be rust proof, termite proof, and water tight and non-hygroscopic in nature and shall conform to IP65.
- The enclosure box must have a standard lock which cannot be opened by commonly available tools. SS309 will be reference materials for Lock.
- EESL shall be providing the design and size/specification of sticker including the logo after the award of work. For placement of sticker, an area of 9"X7" should be available on the front of the box.
- Wiring inside the enclosure box should be done neatly with proper use of connectors & numbering with use of Ferrules and cables should be run in a PVC duct to the extent possible. The enclosure should have theft control mechanism by generating alerts when opened or if the unit experiences motion of any kind beyond a configured threshold.
- EESL PO nos. must be incorporated with permanent marker inside and outside of the CCMS Box.

The general layout and electrical circuit of the CCMS

The CCMS shall be built on the principle of uniformity and interchangeability of parts of any Successful Bidder at any time to meet and shall follow the **following electrical circuit and a layout in construction of a single-phase model.**

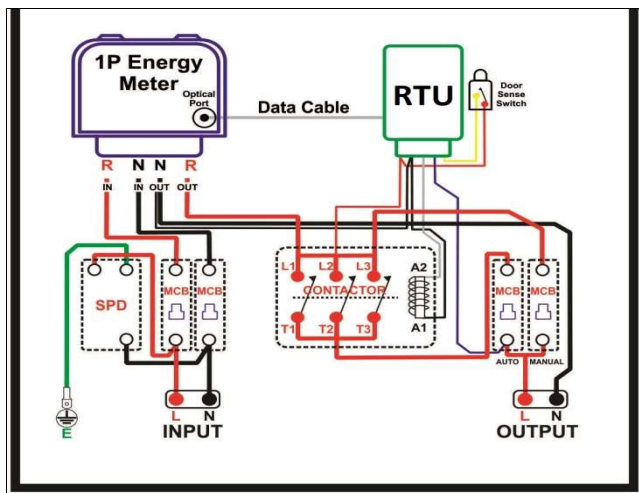

Panel Board for EESL-1P (4030)

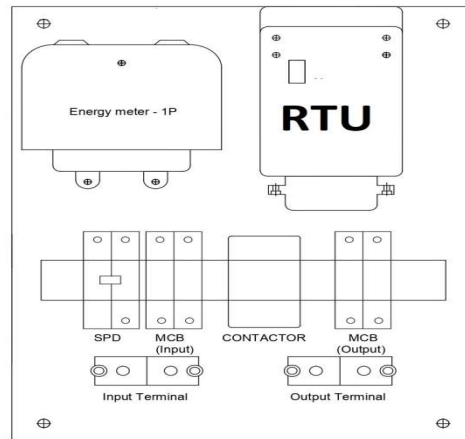

The physical layout and electrical diagram for a three-phase model shall be as follows to facilitate an easy interchangeability of any part by any Successful Bidder at any time during the life of the project.

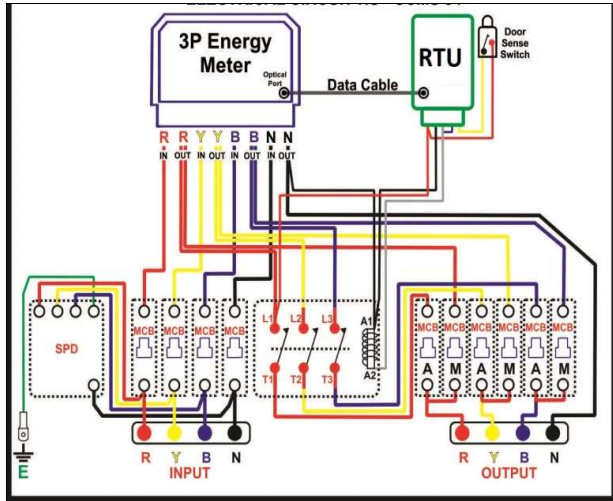

Panel Board for EESL-3P (5345)

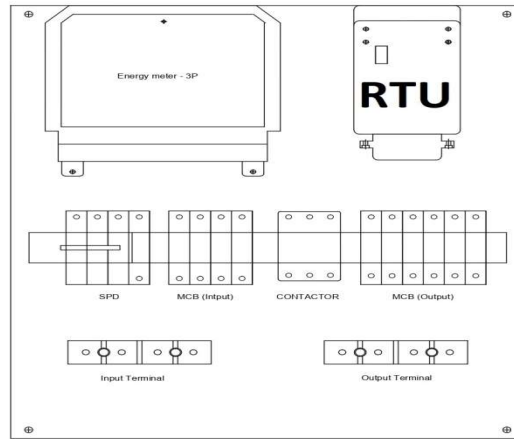

5.1.1.3 Communication Module

- Ability to communicate securely with via cellular networks (GSM / GPRS) and/ or RF networks.
- Communication technology between CCMS unit and central server should be capable to run 2G/3G/4G as per availability in the site during the project period.
- Two-way communicator
- Ability to send data regarding energy usage, ON/OFF status etc. from controller.
- Ability to give commands from a central level for switching ON/OFF scheduling etc. The software for CCMS UI should have provision for providing dimming in case same is provided in the lights.
- Ability to upgrade firmware remotely OTA or on field using a communication device.

5.1.1.4 Software

- A web-based / mobile based software package with a detailed information dashboard.
- Ability to show the status of each controller on the dashboard.
- Inter-operability of all support services related to CCMS units.
- Ability to schedule and switch ON/OFF controllers remotely through the dashboard.
- Reports in form of matrix as well as graphical representation
- Incorporate logics to determine fault detection at switching point level and power thefts and execute a user defined Standard Operating procedure to aid in issue remediation.
- Feed-in CCMS raw data to the central repository. The development/change in the program/schedulers to feed-in data to EESL central repository is in the scope of bidders.
- Dedicated server either on cloud or on-premises with sufficient resources to process and feed-in the data in a timely and regular manner without any fail.
- Dedicated IT SPOC of successful bidder will work in co-ordination with EESL's nodal person to sync CCMS data with EESL central repository.
- EESL may get the bidders IT system audited for security/compliance at any time during the currency of the contract.

5.1.1.5 Hardware

- Server uptime should be minimum 99.99% with disaster backup and sufficient storage capacity and processing power to ensure stable operation of CCMS throughout the contract period. Maintenance of the server and software is the responsibility of the Successful Bidder.

5.2 Specifications

Single phase (240 Volt P-N, Whole Current, Class 1.0) or a Three phase system (Wires 3 * 240 Volts P-N, Whole Current, Class 1.0) electronic controller and energy controller compiled as per IS: 13779 & CBIP-88 with add on MCB.

Single phase or Three phase system electronic controller and energy controller compiled as per the respective IS/IEC for each sub-component of the CCMS with add on MCB. Rating of the CCMS units for each phase (including rating of safety equipment's - MCB, Relay, etc. and as per Amps, wire rating should also be noted) should be

- For 20% quantity of CCMS units - 32 Amps of connected load to each phase is to be considered
- For 40% quantity of CCMS units -63 Amps of connected load to each phase is to be considered
- For the remaining 40% quantity of CCMS Units-100 Amps of connected to for each phase is to be considered.

Note: *The above-mentioned quantities and rating are indicative & may vary with respect to each site based on the detailed field survey to be carried out by the Successful Bidder before project execution. The survey report shall be submitted to the Engineer-in-charge and the work shall be carried out under his/her consent. The Survey report included load details against which the CCMS units shall be supplied and maintained in a ULB.*

Controller is also compatible for remote communication using GPRS/GSM modem for operations like controller data downloading, & relay ON-OFF for maintenance purpose. Controller Records events like supply ON-OFF and relay ON-OFF for analysis etc.

The controller should be type tested in a NABL certified Lab.

The controller should be interfaced with a communication module which would wirelessly transmit data recorded to a dedicated server or on cloud-based architecture. The communication module also relays commands to schedule and control the cluster of street lights.

Street Light Controller

Rated Electrical Parameter

S. No.	Items	Specified Operating Range
1.	Connection type	System for Single Phase/Three Phase Switching points
2.	Voltage	240 volts P-N (+20% to -40% V_{ref}) on each phase
3.	Current	Based on the above mentioned CCMS ratings (Withstands 120% I_{max}), Starting current - $0.2I_b$
4.	Frequency	50Hz $\pm 5\%$ (47.5 to 52.5) Hz
5.	Power Factor	Zero(lag)-Unity-Zero (Lead)
6.	Accuracy	1.0
7.	Withstand Voltage	440V up-to 5 minutes between Phase - Phase
8.	Rating	Rating of the CCMS units for each phase (including rating of safety equipment's - MCB, Relay, etc.) should be -

1. For 20% quantity of CCMS units in a ULB - 32 Amps of connected load to each phase is to be considered
2. For 40% quantity of CCMS units in a ULB -63 Amps of connected load to each phase is to be considered.
3. For remaining 40% quantity of CCMS Units in ULB -100 Amps of connected load to each phase is to be considered.

Functional Specifications

Sr.No	Function/Feature	Details
Input / Output		
1.	Data	<p>The CCMS unit Should be able to capture (record) and provide the following parameters at variable time-intervals.</p> <ul style="list-style-type: none"> • Cumulative Active Energy • Average Power Factor • Power on hours • Monthly Load on/off <p>Controller has the provision to store last 30 days data at one hour interval. All these data is accessible for reading, recording by downloading through HHT (Hand Held Unit) through optical port or USB/Bluetooth given on controller front. For HHT, a smartphone-based solution for collecting/accessing data is also acceptable.</p>
2.	RTC	<p>The controller has a built-in calendar & clock, having an accuracy of +/- 1 minute per year or better, however meter may confirm to accuracy as per IS 13779. A separate internal Lithium battery back-up is provided for continuous operation of controller RTC for project period under controller un-powered conditions. Additionally, the controller should have a built in GPS module-based clock and calendar.</p>
3.	Tampers	<p>Following tampers are logged with occurrence and restoration in FIFO manner:</p> <ul style="list-style-type: none"> • Low Load • Over load • Low Power Factor • Under voltage • Over voltage • Magnet
4.	Astronomical Calendar for switching operation	<p>On the basis of latitude and longitude of the installation place controller itself decides switch on -off timings.</p>
5.	Maintenance Mode of switching	<p>In case of any emergency or for maintenance purpose, switching can be done using keypad -before operation password has to be punched using keypad. For maintenance, the interface for data access should be available. Additionally, a bypass MCB may provide an emergency operation mode bypassing the controller totally.</p>

6.	Switch Weld & Switch Fail events	When Switch “on” operation failed condition is logged as switch fail event and when Switch “off” operation fails condition is logged as switch weld event/external short circuit.
7.	Switch on –off operation events	Switching events with the following reasons will be logged: 6. Timed operation- As per astronomical calendar 7. Unscheduled operation – In maintenance mode Event based like on over current, overload switching All the above events will be sent to the server and in case of failure of communication. The Last 20 events will be logged in controller.
8.	Power on-off events	Last 20 power on-off events with power off duration will be logged.
9.	Separate Energy Consumption registration for unscheduled switch on period	Last 20 events of maintenance mode with snap of energy register and date/time is logged in meter. In BCS, with these events, duration of these events and energy consumption during that period is also shown.
10.	Switching on Overload /Over current	Controller will continue monitor over current & overload condition against the threshold defined in controller and if condition persist for predefined time period (default 5 minutes) then disconnection of switch will occur provided the overload is within 150% of the threshold defined. Controller will reconnect the switch after some predefined time interval (default 10 minutes) and will check again for the event condition, if condition persist again, switch will disconnect again else will run normally. In case of disconnection, controller will try for defined trial count (default 5 count) and after that will disconnect the switch for long defined sleep period (default 30 minutes). After sleep period switch reconnect, activity will restart in same described manner. Every switching operation will be logged in meter.
11.	LED	Flashing RED LED is provided on controller front.
12.	Communication	Controller stored data can be downloaded through its optical port or USB using HHT (Hand held Unit) or directly by Laptop using Base computer software. Controller should be able to interface with the communication module through a serial port/Bluetooth/LoRa.
13.	Programmable Scheduling	The schedule for light operations can be programmed on field or during installation overriding the Astro-clock.
14.	Operating temperature	0 ⁰ C to 70 ⁰ C
15.	Storage temperature	-20 ⁰ C to 80 ⁰ C
16.	Humidity	95% non-condensing

Display and keypad

- LCD (Six Digits, 10mm*5mm, backlit) is provided to display the controller parameters. Additionally, a mobile based app may facilitate using the mobile screen to display the controller parameters.
- A keypad/ optical/ USB port/ Bluetooth/ suitable interface should be provided to access the information stored in the module and system programming
- Hand Held Unit should be universal & have a provision for secure login.

Constructional specifications

S. No.	Descriptions	Details
1	Controller sealing	Energy Meter sealing as per IS 13779 and CEA Metering Regulation 2006
2	Guarantee	Entire Contract Period
3	Insulation	Withstand an insulation test of 4 KV and impulse test at 6 KV
4	Resistance of heat and fire	The terminal block and Controller case have safety against the spread of fire. They will not be ignited by thermal overload of live parts in contact with them as per the relevant IS 13779.

Latching Relay/Bi-Stable Switch/Isolation device/MCB

- Should conform to IEC - 61036/ 61037

Contactors

- Contactor confirming to relevant IEC/IS Standard. Alternatively, an MCB may replace a contactor as a power switch.

MCB

- Should conform to IEC-60898
- MCB along with design for protection & auto-recovery/self-healing is mandatory.

Controller Gateway (Communication Module)

Sr.No	Function/Feature	Details
1.	Power Supply	240 VAC
2.	Mobile / Communication Network	GSM/GPRS: Quad band 850/900/1800/1900 MHz
3.	Communication Method	TCP – IP via GPRS / 3G and/ or RFSMS
5.	Status of Sim	Based on LED on the module

Features:

- Remote ON/OFF in case bad weather, maintenance or emergency
- Remote RTC Synchronisation of Street Light Controller
- Communication should be encrypted by 128-bit encryption.
- Alert message in pre-defined abnormal system conditions through SMS and Whatsapp/email/Mobile app to concern site supervisor/in-charge, relevant authorities and mobile/web-based application through GSM/GPRS/RF for:
 - Phase-wise currents on crossing threshold values*

- Phase-wise voltages on crossing threshold values*
- MCB trips
- Theft alerts
- Group failure of lights
- No output supplies
- Disconnected CCMS (Network failure beyond pre-defined time)

Web based software.

Central Control and Monitoring System functionalities

- CCMS shall have a web-server to receive and record all data from the streetlight controllers.
- EESL may launch PAN India Unified Software. The software of the Successful Bidder should be able to feed-in data & should be inter-operatable to the PAN India unified Software so that all necessary monitoring and operation can be done from the PAN India unified single software as well.
- EESL may develop the platform to receive CCMS data into central repository to store and process CCMS data. It is Successful Bidder 's responsibility feed-in CCMS raw data to the central repository. The development/change in the program/schedulers to feed-in data to EESL repository is in the scope of Successful Bidder.
- The Successful Bidder should have dedicated server either on cloud or on-premises with sufficient resources to process and feed-in the data in a timely and regular manner without any fail.
- Successful Bidder to appoint a dedicated IT SPOC who will work in co-ordination with EESL nodal person to sync CCMS data with EESL central repository.
- EESL may get the Successful Bidders IT system audited for security/compliance.
- The CCMS online web-based software shall primarily comprise of the following pages:
 - Login Page
 - Summary page (Switch point & Luminaires segregated in categories)
 - List of CCMS as per the categories defined in the Summary page & linked to it.
 - Panel data of individual CCMS linked to list of CCMS.
 - List of all CCMS having provision of viewing by zone/division/ward etc.
 - S. Live feed of all CCMS having provision of viewing by zone/division/ward etc.
 - Map view
 - Panel detail
 - Reports
 - Logout
- Further detailed page design & parameters to be displayed shall be explained at later stage.
- The Main page of software to shows real-time information about the cumulative load, number of faulty lights, total number of lights on/off (uptime %), number of faulty lights, number of faulty switching points. On establishment of theft, an alert should be raised to the relevant authority and further escalation to higher authorities depending upon the continuation of theft & pilferage. A separate tab in the software to show the list of CCMS units installed in the project area along with the meter parameters being showcased against each CCMS Unit.
- Alert in case of fault – describing the fault. Along with colour coding for unresolved faults based on time. Eg. One colour for fault which is unresolved for 0-12 hours, different colour for 12-24 hours and so on and so forth.
- A separate tab in the software to show the switch point summary which showcases the meter parameters, active alerts, link to the map page, etc.
- A separate tab in the software for - monitoring& controlling, Alerts, Maps, Configuration page, Reports – uptime, fault penalty, history, energy savings, power failure, operational hour, lamp failure.

- The server should display the faulty lights in each phase separately, instead of giving a total figure of faulty lights for all the 3 phases together.
- It should be able to communicate with any individual switching points or collectively amongst networked switching points for control and monitoring.
- It should be able to record, by association to a switch point, glowing and non-glowing hours of a group of LED luminaires attached to a particular switching point.
- It should be able to display the power failure details of a particular switching point.
- It should register all fault conditions like excess voltage/current drawn, lamps failure (by association to a significant drop in consumption), no-power supply, etc. through the instantaneous alert messages sent by the CCMS unit.
- It can generate MIS reports in Matrix as well as in Graphical format based on Power supply status, Energy Consumption, Over/Under Voltage/Load, System parameter / controllers i.e. Voltage, Current, Power factor, Cumulative kWh/kVAh for individual switching points.
- It should be able to track the failure of lamps in a particular switching point by triggering alarm due to significant drop in power consumption.
- Different user authorization levels should be settable and the central server should be capable of handling high traffic.
- GIS Mapping should be done covering all switching points and the details of each switch point shall be viewable in the web application software through a Google-map interface or web based digital map.
- All the CCMS units should be remotely configured from the Central Control Unit:
 - Setting new ON/OFF timings
 - Setting the RTC time of Automation unit
 - Knowing the current status of any particular switching point.
 - Reset the unit.
 - The minimum interval for the update of data should be 15 minute but programmable up to 1 minute.
- Auto synchronization of controller with server timing to be further synchronized with standard GPS clock timing.
- Further system is able to indicate various faults.
 - Failure of lights (by association to a drop-in power consumption against a set benchmark)
 - Failure of contactor
 - Status of the incoming supply (power failure)
 - High /low voltage
 - Overload on the phases
- System to report Jamming/ hacking attempts and maintain status-quo in case of Jamming/ hacking attempts i.e. if lights are ON, they should remain ON till the default OFF time recorded in the system. In case lights are OFF at the time of Jamming attempt/ hacking, lights should remain OFF till default ON time recorded in the system.
- Software to have asset management features for tracking of each street light, unique asset tag no., make, wattage, date of installation, date of replacement, reason for replacement
- Software to have complaint handling system for light failures, with citizen interface and means of communicating repair update to complaining citizen through SMS.
- Ability to remotely upgrade the CCMS device firmware from central server.
- After completion of installation of CCMS, Successful Bidder has to provide source code of the software to EESL without any additional cost.
- EESL has already developed the platform to receive CCMS data into central repository to store and process CCMS data. It is bidder's responsibility feed-in CCMS raw data to the central repository. The development/change in the program/schedulers to feed-in data to EESL repository is in the scope of bidders.

- The bidder should have dedicated server either on cloud or on-premise with sufficient resources to process and feed-in the data in a timely and regular manner without any fail.
- Bidders to appoint a dedicated IT SPOC who will work in co-ordination with EESL nodal person to sync CCMS data with EESL central repository.
- EESL may get the bidders IT system audited for security/compliance.

Hardware, Security and Other features

- Each CCMS unit is capable of handling a minimum of 100 number switching point units.
- CCMS shall have server preferably dedicated server set-up or cloud based arrangement to ensure 100% guarantee of the data transmission and real time data storage for last 2 years (24 Months) and archived data for the entire contract period.
- Data authenticity and validation has to be ensured.
- Cyber security, safe database management, data retrieval and trouble-free operation of software and allied systems (24*7) to be ensured.
- During the maintenance phase, the Successful Bidder is required to set up a monitoring facility comprising of Data Monitoring Personnel(s), Computers, Display screens, Internet, Landline/Mobile (for co-ordination with site staff) etc. in appropriate numbers specific to the ULB for assessment of CCMS generated data on day-to-day basis. This can also be at a place other than the project site if the Successful Bidder can meet the functional requirements.
- Also, it is expected from the CCMS Successful Bidder to engage sufficient manpower at site for CCMS maintenance. Based on the number of CCMS units to be installed, an appropriate manpower structure shall be submitted by the Successful Bidder as per provision of for each type of works.

Following is mandatory list of materials (but not limited to) to be included in the streetlight controller for above configuration. Bidder shall use required material per unit so as to ensure the entire specifications as given in the tender document are met.

1	IP 65 or better enclosure box with min. IK-10 or impact resistance
2	Miniature Circuit Breaker (MCB)
3	Class 1.0 accuracy Smart meter of Current rating of 10-60A
4	Door Tamper Switch
5	Access through Handheld unit device (HHT) - 1 nos. per ULB

6. Bill of Quantity

6.1. Following is the tentative quantity for Centralized Control & Monitoring System (CCMS) units under GHMC project, Zone-Wise/ Circle-Wise details are provided below:

S. No.	Zone ID	Zone Name	Circle ID	Circle Name	Approx. no. of CCMS	Approx. no. of lights connected
1	2	Charminar	6	Malakpet	1,205	18,306
2	2	Charminar	7	SanthoshNagar	916	13,367
3	2	Charminar	9	Charminar	860	13,093
4	2	Charminar	8	Chandrayanagutta	1,104	18,546
5	2	Charminar	10	Falaknuma	964	14,533
6	3	Khairtabad	12	Mehdipatnam	1,025	20,799

7	6	Secundrabad	16	Amberpet	780	14,431
8	6	Secundrabad	15	Musheerabad	750	12,653
		Total			7,604	1,25,728

6.2. Following is the tentative quantity for Centralized Control & Monitoring System (CCMS) units under Telangana street lighting project, ULB-Wise details are provided below:

S. No.	ULB Name	No. of CCMS	Project Start Date	Project completion Date	Approx. no. of months for R&M (considering LoA w.e.f. from 01-05-2024)
1	Amarchinta Municipality	20	14-12-2020	15-12-2027	44
2	Ameenpur Municipality	215	01-10-2020	02-10-2027	42
3	Atmakur Municipality	35	09-08-2020	10-08-2027	40
4	Bandlaguda Jagir Municipality	300	28-07-2020	29-07-2027	39
5	Bollaram Municipality	95	13-08-2020	14-08-2027	40
6	Cherial Municipality	38	06-11-2020	07-11-2027	43
7	Choppandandi Municipality	39	16-07-2020	17-07-2027	39
8	Dhammaiguda Municipality	280	05-11-2020	06-11-2027	43
9	Dharmapuri Municipality	30	25-02-2021	26-02-2028	47
10	Dundigal Municipality	229	27-11-2020	28-11-2027	44
11	Ghatkesar Municipality	90	25-09-2020	26-09-2027	41
12	Jawharnagar Municipality	39	16-02-2021	17-02-2028	46
13	Kompally Municipality	86	26-06-2020	27-06-2027	38
14	Kosgi Municipality	15	15-10-2020	16-10-2027	42
15	Kothakota Municipality	70	19-09-2020	20-09-2027	41
16	Kyathanpally Municipality	35	03-03-2021	03-03-2028	47
17	Luxettipet Municipality	146	03-10-2020	04-10-2027	42
18	Makthal Municipality	15	10-09-2020	11-09-2027	41
19	Manikonda Municipality	326	18-09-2020	19-09-2027	41
20	Manthani Municipality	55	31-12-2020	01-01-2028	45
21	Maripeda Municipality	80	01-10-2020	02-10-2027	42
22	Mothkur Municipality	33	23-10-2020	24-10-2027	42
23	Nagaram Municipality	195	30-09-2020	01-10-2027	42
24	Nandikonda Municipality	37	20-03-2021	20-03-2028	47
25	Narayankhed Municipality	40	17-01-2021	18-01-2028	45
26	Narsapur Municipality	63	03-02-2021	04-02-2028	46
27	Narsingi Municipality	249	22-09-2020	23-09-2027	41
28	Naspur Municipality	93	30-11-2020	01-12-2027	44
29	Neredcherla Municipality	58	21-08-2020	22-08-2027	40
30	Nizampet Municipality	181	02-03-2021	02-03-2028	47
31	Parigi Municipality	58	07-11-2020	08-11-2027	43

32	Pebbair Municipality	25	23-09-2020	24-09-2027	41
33	Pocharam Municipality	160	18-08-2020	19-08-2027	40
34	Raikal Municipality	31	28-09-2020	29-09-2027	42
35	Shamshabad Municipality	148	19-11-2020	20-11-2027	43
36	Shankarpally Municipality	88	10-09-2020	11-09-2027	41
37	Sulthanabad Municipality	55	17-07-2021	17-07-2028	51
38	Tellapur Municipality	119	01-07-2020	02-07-2027	39
39	Thoopran Municipality	20	04-04-2021	04-04-2028	48
40	Thorrur Municipality	65	15-05-2020	16-05-2027	37
41	Thukkuguda Municipality	85	28-09-2020	29-09-2027	42
42	Thumkunta Municipality	115	31-03-2021	31-03-2028	48
43	Tirumalagiri Municipality	62	24-08-2020	25-08-2027	40
44	Turkayamjal Municipality	210	18-11-2020	19-11-2027	43
45	Wardhannapet Municipality	30	03-10-2020	04-10-2027	42
46	Wyra Municipality	60	10-11-2020	11-11-2027	43
47	Yadagirigutta Municipality	60	24-10-2020	25-10-2027	42
48	Yellareddy Municipality	51	12-10-2020	13-10-2027	42
	Total	4,629			

Note: Any other item/ material/ equipment/ system as may be required to be supplied for completing the work and successful commissioning under this contract in all respects in accordance with the provisions of the contract and/or to ensure the safety of installation during and after execution should be carried out by successful Bidder at 'No extra cost to EESL'.

7. Terms of Payment

- 7.1. Bidder has to raise quarterly invoice at the end of each quarter, as per the "Per Quarter Price" quoted by bidder in Price Bid.
- 7.2. **100% of "Per Quarter price" quoted will be released** towards "Refurbishment and Repair & Maintenance along with comprehensive on-site warranty" on submission of Bill(s)/ Invoice(s) to EESL, at the end of each quarter till the completion of contract period of respective ULB.
- 7.3. Bidder can claim payment, at the end of each quarter subject to Quarterly Satisfactory Repair and Maintenance Certificate (mentioning period of maintenance) from EIC along with ULB wise maintenance report and dashboard reports as per Terms of LOA.
- 7.4. However, the "**final quarter**" will be determined based on the completion of the respective ULB. In case, final quarter period less than three months, beyond 1 month, same shall be calculated proportionality on pro-rata basis for actual number months work executed.

Payment will be released within 60 days of submission of original invoices with following compliances:

- a) During releasing of First Quarter Invoice Successful Bidder has to submit following:

- i. Submission of CCMS commissioning report jointly signed by authorized representative of EESL, PMC agency & Successful Bidders, which will indicate the nos. of CCMS retrofitted/ refurbished and commissioned, Unique ID number of each CCMS, Location of CCMS, number of streetlights connected to each CCMS with power rating of the connected LED fixtures.
 - ii. Submission user id and password of CCMS portal to maintain the database for streetlight & CCMS maintenance.
- b) If the invoice is incomplete, i.e., without complete set of documents then payment due date will start from the date of submission of all necessary documents.
 - c) Confirmation of receipt of 5% spares duly acknowledged by EIC shall be provided along with the invoice, failing which 5% payment shall be retained. Such retained payment shall be released only after getting the confirmation of receipt of spares from EIC.
 - d) Quarterly ULB wise maintenance report of CCMS to be provided by the successful bidder. (i.e., Complaint raised, resolved within 48 hrs, resolved after 48hrs, pending complaint by maintaining the 98% uptime of CCMS).
 - e) Monthly Service Level report generated by CCMS portal.
 - f) If the invoice is incomplete, i.e., without a complete set of documents then payment due date will start from the date of submission of all necessary documents.
 - g) The quarter-wise payment against R&M will be according to Purchase order issued by EESL with mentioned R & M periods in years and accordingly R & M payment applicable.
 - h) Payment towards last quarter will be released after completion of contract agreement of EESL with respective ULB.

Other terms and Conditions of Payment:

- a) The Agency must submit all the documents/reports as per the deliverables of this tender document. If work is not completed within the timelines as mentioned in the Scope of Work/ Deliverable or as provided by EESL, then respective payments will be done after deductions of the LD (Liquidated Damages) amount as per the relevant LD clause or other amounts as per terms & conditions.
- b) The payment shall be processed only upon receipt of (i) Acknowledgement of LoA and signing of contract agreement; (ii) submission of CPG as per tender documents in addition to deliverable documents.
- c) Agency will raise/submit GST Invoice as per prescribed format in GST law or as per the law for the time being in force, only after compliance of Payment Terms and its certification by EESL Engineer in charge (EIC) or its authorized representative.
- d) The payment shall be inclusive of all charges except applicable GST, which shall be paid extra. Taxes should be indicated separately on the invoice.
- e) The amount will be payable in Indian Rupees as per payment milestones/ terms after successful completion of services rendered as per the deliverables mentioned in scope of work.
- f) No advance payment shall be made.
- g) Payment shall be released upon the passing of GST- ITC to EESL within prescribed timeframe in GST Law and after deduction of all applicable Taxes (Direct and indirect).

- h) At the time of payment of bills, the income tax, if any, shall be deducted at source as per Government rules and guidelines as may be prevailing at the time of payment. Further, for availing the benefit of lower income tax rates supplied from outside the Purchaser's country. Supplier shall provide Income Tax Clearance Certificate (ITCC)/ Tax Residency Certificate or any other relevant document/certificate as per prevailing law, from concerned tax authorities for claiming lower tax deduction, if any.
- i) Payment will be made to the bidder within 60 Days after submission of Invoice complete in all respect i.e. with all the required documents and compliance of relevant terms & conditions of LOA duly accepted & certified by EIC, EESL.

8. Payment towards Taxes and Duties:

Employer is liable for and shall pay only applicable GST on various components of prices.

Implementing Partners are required to quote their prices inclusive of all taxes and duties except applicable GST. The Input Tax Credit (ITC) available, if any, under the GST Law as per the relevant Government policies wherever applicable shall be taken into account by the Implementing Partner while quoting bid price. EESL's liability shall be only for applicable GST.

No increase in Taxes and Duties (in case of change), which are payable as per the Contract, shall be allowed beyond the original delivery/ services/ Installation dates unless specifically stated in the Time Extension Letter, if any, issued by the Employer. The Employer will, however, be entitled to any decrease in the Contract Price which may be caused due to lower payable Taxes and Duties amount in case of delivery of Goods/ Installation beyond the original delivery/Installation dates. Therefore, in case of delivery of Goods/Installation beyond the original delivery/ Installation dates, the liability of the Employer shall be limited to the lower of the payable Taxes and Duties amount which may work out either on schedule date or actual date of despatch of Goods/ Installation.

Notwithstanding anything above or elsewhere in the contract, in event that input Tax credit of the GST charged by the supplier, is denied by the tax authorities to the employer for reasons associated with non-compliance/incorrect compliance by the supplier, the employer shall be entitled to recover such amount from the supplier by way of adjustment from any of the subsequent invoices submitted by the supplier to the employer. In addition to the amount of GST, the employer shall be entitled to recover interest and penalty, in case any interest/or penalty is imposed by the tax authorities on the employer for incorrect/wrong availment of input tax credit. The employer shall determine whether the denial of credit is linked to the non-compliance/indirect compliance of the supplier and the said determination shall be binding on the supplier.

9. Taxes, Duties & Levies:

Prices shall be inclusive of all taxes and duties (Except GST). However, IT as per applicable rate will be deducted from your bills as Tax Deduction at Source (TDS). Any other charges/cost/TA/DA is also included in the quoted price.

10. Contract Validity:

- 10.1. The refurbishment work has to be completed within One (1) month from the date of issuance of LoA.

- 10.2. The Repair and Maintenance along with comprehensive on-site warranty of CCMS will start from the completion of refurbishment period (i.e., 1 month) and continue until the project completion of the respective ULB.
- 10.3. EESL reserves the right to terminate the contract under the circumstances where any of the contractual obligations are not met or in case of discrepancies arises in the documents submitted to EESL.

11. Price basis:

For guidance, it is clarified that charges for the following are considered as part of the prices quoted.

- 11.1. Design, Manufacturing, Testing, Supply & transportation, transit Insurance, Loading and unloading Storage Handling Accounting (including reverse supply chain) of CCMS being installed /retrofitted/ refurbished.
- 11.2. The supplier is responsible for refurbishment/ the supply of new CCMS within stipulated timeframe.
- 11.3. Additional, buffer stock of Spares (MCB, SPD, contactor/relay, power supply, set of connectors, tested PCBs, terminal block).
- 11.4. Charges for all activities and supply of materials to be carried out under annual warranty for entire contract period from the date of completion of refurbishment/ installations as certified by respective ULB and EESL.
- 11.5. Storage and handling are in scope of bidder till the supplies are handed over and accepted by EESL representatives.
- 11.6. Cost which may be incurred for compliance / fulfilment of all statutory requirements as per applicable laws/regulations including provisions under SAFETY specified under Scope of work w.r.t manpower deployed, resources, licenses etc.
- 11.7. Charges for Type Tests carried out at NABL Accredited Laboratory/International Lab of equivalent accreditation shall be borne by the Bidder until one successful instance of testing, for CCMS of each phase & design and for additional CCMS in case of change in design.
- 11.8. Cost of selection and supply of Spares (MCB, SPD, contactor/relay, power supply, set of connectors, tested PCBs, terminal block) as per tender spec including cost of coordination testing with CCMS.
- 11.9. Charges for any other activity which is required to be performed to achieve completion of all activities under the scope of work unless otherwise excluded in writing as part of LOA provisions.

12. Guidelines to the Bidders - Walk through survey for analysis of existing infrastructure at ULBs while submitting bid:

While submitting the bid, it may be prudent that the bidder visits any of the ULBs/sites to analyse the existing infrastructure as available at the project areas to understand the existing electrical distribution network, CCMS installations, type of connections, special features of the existing network, type of poles, switching arrangements including local resources, local ambient conditions which have impact on operation and maintenance of the CCMS and their connection arrangements, etc.

13. Technical experience:

- 13.1. The bidder should have its own Lighting Management Software (LMS). Bidder shall provide self-declaration on their letterhead to this effect.
- 13.2. The bidder should have quality certifications for its services function. i.e., ISO 9001:2008. Note: Valid Certificate Copies need to be submitted.
- 13.3. The bidder must have an internal testing facility for testing electrical & electronics items of the tendered item and thermal, ingress protection & other safety tests. Bidder shall provide self-declaration on their letterhead to this effect.

14. Evaluation Criteria:

- 14.1. Tender will be evaluated separately for each Package as stated in BILL of Quantity for 02 Packages.
- 14.2. Bidders can participate in either any or all Packages, if they can manage to accomplish the suggested timeline as per scope of work.
- 14.3. Bidders need to submit an undertaking mentioning the number of Packages they are participating as per Attachment-X of Section-6.
- 14.4. In the price bid to be submitted online, the bidder needs to fill-up relevant fields, viz., the unit rate quoted.
- 14.5. Prices will be evaluated as brought out in the Price bid of Section-4.
- 14.6. The bidder with the lowest price per package shall be designated as the lowest bidder (L-1) of respective package.
- 14.7. Award of work shall be on L-1 basis.
- 14.8. In case L-1 bidder backs out, opportunity will be provided to subsequent bidders in hierarchical order, i.e. L-2, L-3, L-4.....and so on to match the L-1 price.
- 14.9. If any other unforeseen situation/s arise apart from those mentioned above, decision of EESL shall be binding on the Bidders.
- 14.10. In the event of tie in prices between two or more bidders, then preference will be given to the bidder with more average annual turnover (ATO) for the last three years.
- 14.11. Please note that in all cases Matching of Prices will be on total landed cost for complete scope of work for respective packages.
- 14.12. Please note that Tender Conditions applicable for MSE and Startups are mentioned at Annexure-II.

15. Action by EESL if L1 backs out:

After opening of price bid, if L1 bidder backs out, the bidder will be put on holiday list of EESL for a period of one year. During this tenure, the bidder will be barred from participation in EESL tendering process. However, bidder has to continue the unexecuted work of the other prevailing work if any under the current running contracts. Simultaneously, the EMD submitted by such bidder against the subject tender will be forfeited. If bidder is exempted from submission of EMD, then the EMD amount will be adjusted from the payments due to the contractor against other running contracts. If there is no running contract of the bidder/ no payment dues of the bidder, then EESL reserves the right to take any legal remedy as deemed fit to recover the penalty equivalent to EMD amount through legal means.

16. Adjudicator:

Adjudicator under the contract shall be appointed by the Appointing Authority i.e. CEO (EESL). If the bidder does not accept the Adjudicator proposed by EESL, it should so state in its bid form and make a counter proposal of an adjudicator. If on the day the contract agreement is signed, the EESL and Bidder have not agreed on the appointment of adjudicator, the adjudicator shall be appointed, at the request of either party, by the appointing authority specified.

17. Arbitration:

Arbitration shall be carried out as per Arbitration Act 1996 and its subsequent Amendment. The Contract shall be governed by and interpreted in accordance with the laws in force in India. The courts of Delhi shall have exclusive jurisdiction in all matters arising under the contract.

18. Contract Performance Guarantee:

Within twenty-eight (28) days of the receipt of the notification of award towards the Contract from EESL, the supplier shall furnish Contract Performance Guarantee (CPG) in the form of a DD/Pay Order/Bank Guarantee (BG) for **5% of Cost of "Refurbishment and Repair & Maintenance of CCMS along with comprehensive on-site warranty for One Year"** The Bank Guarantee must be valid for Project Period + Three Months Claim Period.

Any delay in submission of SD/CPG shall be deemed as accruing of financial benefit to the bidder(s) and EESL may take necessary interest penalty recovery action (interest @ State Bank of India's MCLR + 2 %) from the payments due to the bidder(s) for the period of delay. However, this provision does not bind EESL in any way from proceeding against the bidder(s) (including forfeiture of EMD, cancellation of the LOA, etc.) for non-compliance towards non-submission of the SD/CPG.

The BG shall be from any Nationalized Bank/other scheduled Private banks/International banks, to be from among the list of banks given at Attachment-6 of Section-6. In case of international bidder(s), the CPG BG could be from any such International bank having a branch in India or a Nationalised Indian bank having a branch in the country of origin of the international bidder(s) mentioned in Attachment-15 of Section-6. The International Bidders are also required to enclose with their CPG BG a letter of BG confirmation from a corresponding Indian bank. EESL shall at its discretion have recourse to the said Bank Guarantee for the recovery of any or all amount due from the bidder(s) in connection with the contract including of replacement warranty obligations.

Failure of the bidder(s) to comply with the requirements of IFB/Tender/NIT/LOA shall constitute sufficient grounds for the annulment of the award and forfeiture of the SD/CPG.

"This Bank Guarantee shall be effective only when BG issuance message is transmitted by the issuing bank through SFMS to ICICI Bank include unique identifier EESL543840944 in field 7037 of the SFMS cover messages with IFSC Code ICIC0000007".

BG advising message - IFN 760COV / IFN 767COV via SFMS	
Field Number	Particulars (to be mentioned in Row 1)
7037	EESL543840944

19. Contract Agreement:

The bidder must submit the signed Contract Agreement to Contract's Dept. within 07 days after the issuance of LoA.

20. Quantity Variation:

EESL reserves the right to change the quantity be awarded and for variation in BOQ up to +/-20% on one or more items subject to total variation in LOA Quantity limited to +/- 20%.

21. Safety:

- 21.1. The BIDDER shall bear all expenses/cost to be incurred towards salary, allowances, perks, traveling allowances, advances, insurance, safety measures, security, transportation and all other misc. expenses etc. of their employees/ workmen during the tenure of installation. Also, the BIDDER shall be solely responsible for making payment for Hospitalization, Compensation thereof in case of any accident, injury or Casualty.
- 21.2. The BIDDER shall issue Identity Cards to their employees deployed for execution of the assigned works in the District with the consent of Engineer In charge.
- 21.3. The BIDDER should ensure that there are no disputes regarding service, payment etc of the persons engaged by him, anytime during the currency of the contract. At no point of time during the currency of contract, the BIDDER's employees shall insist upon the EESL for employment, wages, and allowances or any other related matter, payment etc.
- 21.4. The BIDDER to deploy their manpower immediately for carrying out the work as specified above.
- 21.5. The BIDDER shall not deploy the manpower below the age of 18 years.
- 21.6. The BIDDER shall not deploy the female manpower between 7 PM to 6 AM.
- 21.7. The BIDDER shall be directly responsible for any / all disputes arising between him and his persons and keep EESL indemnified against all losses, damages and claims arising thereof. The BIDDER shall resolve any dispute of their manpower. All the legal dues of their manpower is to be paid on due date or within 8 days on the termination of manpower.
- 21.8. All safety wears required for the BIDDER's manpower during the execution of work such as safety shoes, safety helmets, hand gloves, safety belt, dust mask, goggles etc. must be provided by the BIDDER at his own cost and he shall ensure that his employees regularly use such safety gears while executing the work.
- 21.9. The BIDDER shall be responsible for discipline of his manpower and shall adhere to the disciplinary procedure set by the COMPANY at site. The EESL shall be at liberty to object to the presence of any representative or employees of the BIDDER at the site, if in the opinion of the EESL such manpower has done any act of misconduct or negligence or otherwise undesirable, then the BIDDER shall remove such a person objected to and provide a competent replacement immediately.
- 21.10. Bidder must Deduct and deposit ESI and PF contribution. Copies of the same shall be submitted.
- 21.11. Bidder must ensure the field supervisor and team keep their face covered while working at the site.
- 21.12. Norms of Social distancing must be followed to the maximum extent. In case anyone shows symptoms of COVID19, he should be immediately isolated and further action as per the Govt. advice shall be taken.

22. Liquidated Damage (LD):

- 22.1. Penalties and Liquidated damages on default of Bidder for Refurbishment and Repair & Maintenance:
 - 22.1.1. In case of any delay in Refurbishment/ Rectification, beyond the stipulated time schedule, EESL reserves the right to recover from the bidder a sum equivalent to 0.5% of the Quoted amount towards One Quarter for each week of delay and part thereof subject to a maximum of 10% of the total value of the contract. LD will not be applicable for the period if delay is not on bidder's part.
 - 22.1.2. Alternatively, EESL reserves the right to avail the from elsewhere/other contractor at the sole risk and cost of the successful bidder/contractor and recover all such extra cost incurred by EESL in avail the services from resources available including EMD/Bid Security/encashment of Bank Guarantee or any other sources etc.
 - 22.1.3. And also, EESL reserves the right to cancel the order completely or partly without any prejudice to the exercise of the actions under Clauses 'a' and 'b' above.

- 22.1.4. In addition to above, following penalties shall be applicable during the entire contract period, over and above the ceiling limits of LD provisions.
- 22.1.4.1. Penalties for non-fulfilment of minimum uptime requirement i.e. 98% and delays in Restoration of CCMS faults shall be,
- Successful bidder shall ensure 98% service level through CCMS for lighting control Unit at any point of time during the contract period. In case of failure of CCMS which is brought to the notice of successful bidder (by mail, letter etc.), the same has to be attended within 48 hours of the intimation. If Successful Bidder fails to correct the fault within 48 hours, the penalty starts with the first penalty being levied on completion of 72 hours from logging/ intimation of complaint. **Penalty @ Rs. 5 per day per light connected to the CCMS unit** shall be imposed by EESL till the satisfactory rectification of complaint failure.
- 22.1.4.2. Penalties for non-supply of spares during maintenance phase: In case of shortfall of buffer Spares stock (MCB, SPD, contactor/relay, power supply, set of connectors, tested PCBs, terminal block) non-maintenance of the required minimum 5% buffer spares stock beyond 7 days from the date of intimation from EESL, a notional penalty at the rate of Rs. 10,000 per month and part thereof per site shall be charged by EESL.
- 22.1.4.3. Penalties for non-deployment of qualified personnel: Rs. One lakh per month (non-deployment for more than 5 days in any calendar month). Bidder to ensure a deployment of regular Staff as described in tender documents.
- 22.1.4.4. Penalties for non-availability of maintenance team/s: Rs. 25,000 per month per team (non-availability for more than 5 days in any calendar month). Bidder to ensure that each maintenance team must comprises of qualified personnel i.e. at-least 1 technician & 1 helpers.
- 22.1.5. In case, the total amount of penalties mentioned above exceeds the amount of maximum provision under Liquidated Damages, EESL reserves the right to recover the same from CPG or running payments. However, In any case penalties cannot be more than 10% of the contract value over and above the LD Limit of 10% of the total contract value.
- 22.1.6. In addition to the above, if any penalties imposed by client for the default in services then same will be pass on to the Bidder back to back along with applicable taxes..

23. Transportation, Demurrage Wharfage, Etc:

The successful bidders is required under the Contract to transport the Goods to place of destination defined as Site. Transport to such place of destination in India including insurance, as shall be specified in the Contract, shall be arranged by the Contractor, and the related cost shall be included in the Contract Price.

Successful bidder, on whom letter of award is placed, is to ensure all safety guidelines, rules and regulations, labour laws etc. Successful bidder indemnifies EESL for any accident, injury met by its labour, employee or any other person working for him. Any compensation sought by its labour, employee or any other person working for him shall be paid by successful bidder as per settlement solely. EESL has no role to play in this matter.

24. Prices will remain firm till the execution of the contract.

25. Compliance with EESL's EHSS Policy:

The bidder shall necessarily comply with EESL's EHSS (Environment, Occupational Health and Social) policy as applicable to Street Lighting National Program and any further modification(S)/ Addition (S) to EHSS policy.

26. Compliance with all Statutory Regulations:

Compliance of all the statutory requirements as may be required w.r.t the activities to be performed to execute the scope of work under the subject LOA including the requirements under Contract Labor Acts, safety of the workmen deployed, etc., shall be the responsibility of the successful bidder including all the expenditure incurred for the same. This includes all the requirements w.r.t the workmen under Sub-contractor(s) also. The successful bidder shall submit the documentation to EESL, on monthly basis, as required under the applicable statutory requirements.

Successful bidder shall indemnify EESL for any accident, injury met by its labor, employee or any other person working for him. Any compensation sought by its labour, employee or any other person working for him shall be paid by successful bidder as per settlement solely. EESL has no role to play in this matter.

The successful bidder, at their own cost, shall arrange disposal of failed LED Lamps /various part of the Luminaires as per the relevant provisions of various acts/regulation in force from time to time.

27. Insurance:

-NA-

28. Successful bidder is to submit interchangeability certificate for its product supplied for replacement during warranty and maintenance period and even when it is purchased from open market. In case due to change in technology, the supplied product is not available during warranty/ maintenance period than the improved version of product can be used in warranty/ maintenance period with same or improved technical parameters or the combination thereof after written communication of Engineer in Charge at same cost & terms and conditions. Successful Bidder, on whom a letter of award has been placed, has also to confirm that the price of the improved version of the product is not lesser than the original product or its parts in comparison. In the event of lesser price, a suitable discount shall be passed on to EESL to that effect.

29. The Bidder shall be deemed to have examined the Bid document, to have obtained his own information in all matters whatsoever that might affect carrying out the Works in line with the Scope of Work specified in the document at the offered rates and to have satisfied himself to the sufficiency of his Bid. The bidder shall be deemed to know the scope, nature and magnitude of the work and requirement of materials, equipment, tools and labour involved, wage structures and as to what all works he has to complete in accordance with the Bid documents irrespective of any defects, omissions or errors that may be found in the Bid documents.

30. Subsequent to an order being placed against your quotation, received in response to this 'enquiry', if it is found that the materials supplied are not of the right quality or not in accordance with our specifications (required by us) or received in damaged or broken conditions, not satisfactory owing to any reason of which we shall be the sole judge, we shall be entitled to reject the materials, cancel the contract and buy our requirement from the open market / other sources and recover the loss, if any, from the supplier reserving to ourselves the right to forfeit the security deposit, furnished by the supplier against the contract. The supplier will make his own arrangements to remove the rejected material within a fortnight of instructions to do so. Thereafter material will lie entirely at the supplier's risk and responsibility and storage charges, along with any other charges applicable, will be recoverable from the supplier.
31. EESL reserves the right to accept or reject any bid in full or in part without assigning any reason thereof. We also reserve the right to split and place orders on more than one supplier.
32. The bidder should not have been blacklisted by any Central / State Government or Public Sector Undertakings. If at any stage of tendering process or during the currency of the contract, any suppression / falsification of such information is brought to the knowledge, EESL shall have the right to reject the proposal or terminate the contract, as the case may be, without any compensation to the tenderer & forfeiture of bid security/EMD/CPG.

33. **Appointment of NODAL Officer by Successful Bidder:**

For the purpose of this tender, successful bidder needs to provide/submit the Authorization letter (within 3 days from Date of LoA) with name, address, mobile no., email addresses, designations of at least 3 Senior Nodal Officers (Regular Employees of their organization), nominated by their top management (Director/ MD/ CEO), who are reachable through any means of communication and who shall be accountable to deliver the products and associated services to EESL as per the tender.

34. **Correspondence: Post award, all correspondence by successful bidder shall be addressed to as brought out below:**

- **AGM (Contracts)** - for all issues pertaining to clarifications w.r.t contractual and commercial issues or requiring amendments on the terms and conditions of LOA in general.
- **Engineer-In-Charge (EIC)** - all the activities pertaining to execution of the works at site, as per the provisions under the terms of the LOA, on behalf of EESL.

35. **Coordination with PMC:**

EESL may appoint separate agencies for PMC/AMC works, successful bidder has to coordinate with the agencies.

PMC/AMC: On behalf of EESL, for coordination & supervision of various activities, under Project installation and Annual Maintenance Contract periods, with ULB, executing agency and EESL.

Successful bidders shall provide all the relevant information and support to the said agencies for the scope of work covered under LoA placed on the successful bidder. Intimation will be given to the successful bidder by EIC in this regard after placement of LoA.

36. **Compliance with all Statutory Regulations:**

- 36.1. Compliance of all the statutory requirements as may be required w.r.t the activities to be performed to execute the scope of work under the subject LOA including the requirements under Contract Labor Acts, safety of the workmen deployed, etc., shall be the responsibility of the successful bidder including all the expenditure incurred for the same. This includes all the requirements w.r.t the workmen under Sub-contractor(s) also. The successful bidder shall submit the documentation to EESL, on a monthly basis, as required under the applicable statutory requirements.
- 36.2. The successful bidder shall indemnify EESL for any accident, injury met by its labor, employee or any other person working for him. Any compensation sought by its labour, employee or any other person working for him shall be paid by the successful bidder as per settlement solely. EESL has no role to play in this matter.

37. Submission of Reports:

Following Reports shall be submitted by the successful bidder, as per the instructions of EIC:

- 37.1 **Monthly Progress Reports for Repair & replacement of faulty CCMS-** with details of spares (MCB, SPD, contactor/relay, power supply, set of connectors, tested PCBs, terminal block) or any other items repaired/ replaced against the faulty CCMS. The report must specify the item wise % of failure rate. This report needs to be submitted duly signed & sealed by EESL EIC & Supplier until the warranty period.
- 37.2 Monthly state-wise invoice report- with details like invoice number, date of invoice, description of material, supplied qty, invoice value (excluding Tax), with payment released & pending details w.r.t payment milestone against the supply of material shall be submitted to the EIC/State Head.
- 37.3 Spares Inventory Monthly report-on Stock of MCB, SPD, contactor/relay, power supply, set of connectors, tested PCBs, terminal block and any other spares required for prompt service to be provided to the respective state representative/state head.
- 37.4 Dashboard Reports- Reports like uptime, fault penalty, history, energy savings, power failure, operational hour, lamp failure, etc. to be submitted.
- 37.5 **Any other Reports as may be directed by EIC.**

Note: File names of all the documents submitted in soft form shall contain the topic of the subject document.

---- End of Part-C (Technical Specifications) ----

Part - D of Section-4

SPECIAL CONDITIONS OF CONTRACT (SCC)

SPECIAL CONDITIONS OF CONTRACT (SCC)

The following bid specific data shall amend and/or supplement the provisions in the General Conditions of Contract (GCC)

Sl. No.	GCC Clause Ref. No.	Amendment/ Supplement to GCC
1.	GCC1.1	Supplementing Sub-Clause GCC 1.1 The Employer is: M/s. Energy Efficiency Services Limited Buddha Bhawan, 3 rd Floor, North block, MG Road Ranigunj, Secunderabad-500003, Telangana Kind Attn.: Addl. General Manager (Contracts) Email: Primary - asrao@eesl.co.in Secondary -
2.	GCC 3.10	Replace GCC 3.10 with the following: For the subject tender, Joint Venture or Consortium is not applicable.
3.	GCC 6	Supplement GCC 6.2.3 with the following: Arbitration shall be carried out as per Arbitration Act 1996 and its subsequent amendment. The Contract shall be governed by and interpreted in accordance with the laws in force in India. The courts of DELHI shall have exclusive jurisdiction in all matters arising under the contract.
4.	GCC8.2	Supplement GCC clause 8.2 with the following: Time for Completion: The refurbishment work has to be completed within One (1) month from the date of issuance of LoA. The Repair and Maintenance along with comprehensive on-site warranty of CCMS will start from the completion of refurbishment period (i.e., 1 month) and continue until the project completion of the respective ULB.
5.	GCC 13.3.1	Within twenty-eight (28) days of the receipt of the notification of award towards the Contract from EESL, the supplier shall furnish Contract Performance Guarantee (CPG) in the form of Bank Guarantee (BG) of value equal to "5% of Cost of "Refurbishment and Repair & Maintenance of CCMS along with comprehensive on-site warranty for One Year" The Bank Guarantee must be valid for Project Period + Three Months Claim Period.

Sl. No.	GCC Clause Ref. No.	Amendment/Supplement to GCC						
		<p>Any delay in submission of SD/CPG or SFMS confirmation whichever is later shall be deemed as accruing of financial benefit to the bidder(s) and EESL may take necessary interest penalty recovery action (interest @ State Bank of India's MCLR + 2 %) from the payments due to the bidder(s) for the period of delay. However, this provision does not bind EESL in any way from proceeding against the bidder(s) (including forfeiture of EMD, cancellation of the LOA, etc.) for non-compliance towards non-submission of the SD/CPG.</p> <p>In case where CPG has been called for more three years Vendor can submit CPG in two parts, First for 03 Years + claim period and balance PBG will be submitted to contract department prior to 6 months of expiry of previous CPG, In this regard further an under taking has to be submitted by vendor that if vendor fails to provide second BG then EESL can impose the penalty and forfeit the bank guarantee.</p> <p>The BG shall be from any Nationalized Bank/other scheduled Private banks/International banks, to be from among the list of banks given at Annexure-I of Section-6. In case of international bidder(s), the CPG BG could be from any such International bank having a branch in India or a Nationalised Indian bank having a branch in the country of origin of the international bidder(s) mentioned in Annexure I of Section-6. The International Bidders are also required to enclose with their CPG BG a letter of BG confirmation from a corresponding Indian bank. EESL shall at its discretion have recourse to the said Bank Guarantee for the recovery of any or all amount due from the bidder(s) in connection with the contract including of replacement warranty obligations.</p> <p>Failure of the bidder(s) to comply with the requirements of IFB/Tender/NIT/LOA shall constitute enough grounds for the annulment of the award and forfeiture of the SD/CPG.</p> <p>This BG will be released on closure of contract.</p> <p>"This Bank Guarantee shall be effective only when BG issuance message is transmitted by the issuing bank through SFMS to ICICI Bank include unique identifier EESL543840944 in field 7037 of the SFMS cover messages with IFSC Code ICIC0000007".</p> <table border="1" data-bbox="508 1549 1393 1690"> <tr> <td colspan="2" data-bbox="508 1549 1393 1585">BG advising message - IFN 760COV / IFN 767COV via SFMS</td> </tr> <tr> <td data-bbox="508 1585 751 1654">Field Number</td> <td data-bbox="751 1585 1393 1654">Particulars (to be mentioned in Row 1)</td> </tr> <tr> <td data-bbox="508 1654 751 1690">7037</td> <td data-bbox="751 1654 1393 1690">EESL543840944</td> </tr> </table>	BG advising message - IFN 760COV / IFN 767COV via SFMS		Field Number	Particulars (to be mentioned in Row 1)	7037	EESL543840944
BG advising message - IFN 760COV / IFN 767COV via SFMS								
Field Number	Particulars (to be mentioned in Row 1)							
7037	EESL543840944							

Sl. No.	GCC Clause Ref. No.	Amendment/Supplement to GCC
6.	GCC 14.2	<p>Replace clause 14.2 with the following:</p> <p>Employer is liable for and shall pay only applicable GST on various components of prices. Implementing Partners are required to quote their prices inclusive of all taxes and duties except applicable GST. The Input Tax Credit (ITC) available, if any, under the GST Law as per the relevant Government policies wherever applicable shall be taken into account by the Implementing Partner while quoting bid price. EESL's liability shall be only for applicable GST.</p> <p>No increase in Taxes and Duties (<i>in case of change</i>), which are payable as per the Contract, shall be allowed beyond the original delivery/ Installation dates unless specifically stated in the Time Extension Letter, if any, issued by the Employer. The Employer will, however, be entitled to any decrease in the Contract Price which may be caused due to lower payable Taxes and Duties amount in case of delivery of Goods/ Installation beyond the original delivery/Installation dates. Therefore, in case of delivery of Goods/Installation beyond the original delivery/ Installation dates, the liability of the Employer shall be limited to the lower of the payable Taxes and Duties amount which may work out either on schedule date or actual date of dispatch of Goods/ Installation</p> <p>Notwithstanding anything above or elsewhere in the contract, in event that input Tax credit of the GST charged by the supplier, is denied by the tax authorities to the employer for reasons associated with non-compliance/ incorrect compliance by the supplier, the employer shall be entitled to recover such amount from the supplier by way of adjustment from any of the subsequent invoices submitted by the supplier to the employer. In addition to the amount of GST, the employer shall be entitled to recover interest and penalty, in case any interest/or penalty is imposed by the tax authorities on the employer for incorrect/wrong availment of input tax credit. The employer shall determine whether the denial of credit is linked to the non-compliance/indirect compliance of the supplier and the said determination shall be binding on the supplier.</p>
7.	GCC 25.2	The GCC 25.2 i.e., If applicable (as per Technical Specifications)
8.	GCC 25.3.1	<p>Replace GCC 25.3.1 with the following:</p> <p>Subject to GCC Sub-Clause 25.4 (Partial Acceptance) below, Operational Acceptance shall occur in respect of the Facilities or any part thereof when the Facilities or part thereof have been successfully Completed.</p>

Sl. No.	GCC Clause Ref. No.	Amendment/Supplement to GCC
9.	GCC 25.3.2	<p>Replace GCC 25.3.2 with the following:</p> <p>At any time after the event set out in GCC Sub-Clause 25.3.1 has occurred, the Implementing Partner may give a notice to the Project Manager requesting the issue of an Operational Acceptance Certificate in the form acceptable to the EESL in respect of the Facilities or the part thereof specified in such notice as at the date of such notice.</p>
10.	GCC 26.1	<p>Supplement clause 26.1 with the following:</p> <ol style="list-style-type: none"> 1. In case of any delay by the Contactor beyond the stipulated schedule given at GCC 8.2, including any extension permitted in writing, EESL reserves the right to recover from the Contactor a sum equivalent to 0.5 % of the Contract Price of the unexecuted portion of the work for delay per week or part thereof, subject to a maximum of 10 % of the total Contract Price. 2. Notwithstanding the above, in case of regular and repeated complaints against the Contactor and the Contactor's failure in providing satisfactory after-sales replacement warranty and maintenance services, EESL reserves the right to forfeit the SD/CPS submitted against the LOA towards non- performance of the contract. 3. Alternatively, EESL reserves the right to purchase and distribute material from elsewhere at the sole risk at the cost of Contactor and to recover all such extra costs incurred by EESL in procuring the material from resources available including EMD/Bid Security/encashment of Bank Guarantee or any other sources, etc. Further, if any extra cost is incurred by EESL due to delay in work completion by the Contactor beyond the completion time as per Contract, the same shall also be recovered from Contactor's invoice/EMD/BGs, etc. The Employer may, without prejudice to any other method of recovery, deduct the amount worked out as above from any monies due or to become due to the Contractor under the Contract or any other on-going contract. 4. EESL also reserves the right to cancel the order completely or partly without any prejudice to the exercise of the actions under Clauses 'a' and 'b' above.
11.	GCC 27.2	<p>Replace 1st para of GCC 27.2 with the following:</p> <ul style="list-style-type: none"> • Bidder shall provide SLA as defined in SLA section of the RFP. Bidder shall resolve all types of issues/defects within SLA timelines.
12.	GCC 34	<p>Replace GCC 34 with the following:</p> <p>Not Applicable</p>

Sl. No.	GCC Clause Ref. No.	Amendment/Supplement to GCC
13.	GCC 39.2	<p>Supplement 39.2.3 with the following:</p> <p>During Execution of contract, EESL reserves the right to increase or decrease the quantity of individual contract Items upto any extent subject to following:</p> <p>(i) As long as overall variation remains within + 20% of the contract price, the rate of individual contract items and other Terms & Conditions of the contract shall remain unaltered.</p> <p>In case overall contract price increases by more than 20%, all such items, where executed/anticipated quantity has exceeded/is expected to exceed that's specified in the contract by more than 20%, will be identified. In respect of all such items while the quantity originally specified in the contract +20%extra shall be paid at unit rate available in the Contract, the payment for thebalance quantity shall be released at a rate to be decided after mutual agreement.</p>
14.		<p>Addition of new clause:</p> <p>Evaluation Criteria:</p> <p>14.1 Tender will be evaluated separately for each Cluster as stated in BILL of Quantity for 03 Clusters. Bidders can participate in either any or all Clusters, if they can manage to accomplish the suggested timeline as per scope of work. Bidders need to submit an undertaking mentioning the number of Clusters they are participating as per Attachment-11 of Section-6.</p> <p>14.2 Prices will be evaluated as brought out in the Price bid of Section-4. Suitable bidder having lowest total prices per each cluster shall be L-1. Bidders shall manage to accomplish the suggested timeline as per scope of work.</p> <p>14.3 Award of work shall be on L-1 basis.</p> <p>14.4 In case L-1 bidder backs out, opportunity will be provided to subsequent bidders in hierarchical order, i.e. L-2, L-3, L-4.....and so on to match the L-1 price.</p> <p>14.5 If any other unforeseen situation/s arise apart from those mentioned above, decision of EESL shall be binding on the Bidders.</p> <p>14.6 In the event of tie in prices between two or more bidders, then preference will be given to the bidder with more average annual turnover (ATO) for the last three years.</p> <p>14.7 If any other unforeseen situation/s arise apart from those mentioned above, decision of EESL shall be binding on the Bidders.</p> <p>14.8 Please note that in all cases Matching of Prices will be on total landed cost for complete scope of work for resp. ULBs.</p> <p>EESL reserves the right to disqualify any bidder(s) or the tender based upon itsdiscretion, if the selected bidder(s) has conducted any malpractice during the tender procedure.</p>

Sl. No.	GCC Clause Ref. No.	Amendment/Supplement to GCC
		<p>The illustrative format & notes for price bid shall be referred at ANNEXURE-III.</p> <p>If any other unforeseen situation/s arise apart from those mentioned above, decision of EESL shall be binding on the Bidders.</p>

--- End of Part-D (SCC) ---

SECTION-5

Measurement and Verification (M&V)

----- Not Applicable -----

SECTION-6

Forms & Procedures

List of Contents

Sr.No	Attachment No	Name of the Form
1	Attachment No-X	Declaration of Packages (Format for Package submitted)
2	Attachment No-Y	Bid Security Declaration
3	Attachment No-1	Bid Form (Format of Application)
4	Attachment No-2	Form for Submitting BG Format in lieu of EMD
5	Attachment No-3	Power of Attorney
6	Attachment No-4	Certificate Regarding Acceptance of Important Terms & Conditions
7	Attachment No-5	Deviation Statement
8	Attachment No-6	Form of acceptance of fraud prevention policy
9	Attachment No-7	Proforma of letter of undertaking (in case of Holding Company)
10	Attachment No-8	Real time gross settlement (RTGS)/ National Electronic Fund Transfer (NEFT)
11	Attachment No-9	Compliance Matrix/ CHECK - LIST FOR BIDDERS
12	Attachment No-10	Format for Affidavit of Self certification regarding Local Content in line with PPP-MII order and MoP Order, if applicable
13	Attachment No- 11	Certification by the Bidder as per order no. F.No.6/18/2019-PPD dated 23/07/2020 issued by Public Procurement Division, Department of Expenditure, Ministry of Finance, Government of India (DoE Order)
14	Attachment No-12	Format for filling details related to Qualifying Requirement (QR)
15	Attachment No-13	Certificate regarding non-debarment for false declaration of local content
16	Attachment No-14	Certificate regarding non-debarment/ blacklisting/ disqualification
17	Attachment No-15	Proforma of Bank Guarantee for Contract Performance
18	Attachment No-16	Form of Undertaking By The Joint Venture Partners
19	Attachment - A	Format for Notification of Award to be issued to successful Consultant on letterhead paper of the Employer
20	Attachment - C	Format for Contract Agreement to be signed between successful Consultant and Employer on INR 100/- non-judicial Stamp Paper

List of Appendix to Contract Agreement

Sr. No	Appendix To Contract Agreement	Name of Form	Page No
1	Appendix No-1	Terms and procedures of payment	
2	Appendix No-2	Price adjustment	
3	Appendix No-3	Insurance requirements	
4	Appendix No-4	Time schedule	
5	Appendix No-5	List of approved subcontractors	
6	Appendix No-6	Scope of works and supply by the employer	
7	Appendix No-7	List of documents for approval or review	
8	Appendix No-8	Guarantees, liquidated damages for non - performance	
9	Appendix No-9	Contract Co-ordination procedure	
10	Appendix No-10	Summary of Contract Price for Services for complete scope of the Work as per RfP Documents	

(Declaration for Schedules Quoted by the Bidder)

Ref. NIT/Bid Document No: EESL/06/24-25/SERC-Contracts/TS/CCMS -GHMC & ULB/OTE-232414

Date: 29/08/2024

{Description: _____}

To,
Additional General Manager (Contracts),
Energy Efficiency Services Ltd.,
Buddha Bhawan, 3rd Floor,
North Block, MG Road
Ranigunj, Secunderabad-500003
Telangana.

Sub.: Declaration for the Schedules Quoted by bidder in the Tendered Delivery Period

Ref. above Tender, I/we (on behalf of M/s.....) hereby admit that I/we, have quoted for the following Clusters in the above-referred Tender.

Tender Name	Name of package	Participated (Yes/No)
Refurbishment and Repair & Maintenance of CCMS along with comprehensive on-site warranty (including supply of spares parts) for a period until the project completion of respective ULB in Street lighting project in the state of Telangana	GHMC	
Refurbishment and Repair & Maintenance of CCMS along with comprehensive on-site warranty (including supply of spares parts) for a period until the project completion of respective ULB in Street lighting project in the state of Telangana	ULBs of Telangana	

Signature of the bidder
 With stamp & Address

(*bidder has to mandatorily submit the declaration as above. The bid shall be evaluated on the basis of this declaration. Providing false information may lead to technically non-responsiveness of the bid.)

[Duly Notarized on Rs. 100/- Stamp Paper]

Bid Security Declaration

In reference to EESL Tender For “ _____ [Subject of Tender] _____ ” published vide NIT/Bid Document No: _____ dated: _____, I, on behalf of _____ [Name of the bidder] hereinafter referred to as “Bidder”,

- a) understand that, according to tender conditions, bids must be supported by a Bid Declaration.
- b) hereby submit a declaration that the bid submitted by the undersigned, on behalf of the Bidder, either sole or in JV or Company, shall not be withdrawn or modified during the period of bid validity as mentioned in the tender document.

I, on behalf of the Bidder, _____ [Name of the bidder] _____, also accept the fact that in case the bid is withdrawn or modified during the period of its validity or if _____ [Name of the bidder] _____ fail to sign the contract in case the work is awarded to us or fail to submit a performance security before the deadline defined in the tender document/letter of award, then _____ [Name of the bidder] _____ shall be suspended for participating in the tendering process of EESL, for a period of one (01) year from bid due date of above referred tender.

I, on behalf of the Bidder, _____ [Name of the bidder] _____, also understand that this Bid Securing Declaration shall cease to be valid if I am/we are not the successful Bidder, upon the earlier of

- a) the receipt of your notification of the name of the successful Bidder; or
- b) thirty days after the expiration of the validity of my/our Bid

Signed: _____ (insert signature of person whose name and capacity are shown)
in the capacity of: _____ (insert legal capacity of person signing the Bid Securing Declaration) Name: _____ (insert complete name of person signing the Bid Securing Declaration)

Duly authorized to sign the bid for an on behalf of _____ [Name of the bidder] _____

Dated on _____ day of _____, 2020 (insert date of signing) Corporate

Seal (where appropriate)

(Note: In case of a Joint Venture/Consortium, the Bid Security Declaration must be in the name of all partners to the Joint Venture/Consortium that submits the bid)

BID FORM (FORMAT OF APPLICATION)

ATTACHMENT - 1

Date:-

To,
Addl. General Manager (Contracts)
Energy Efficiency Services Limited.
(A JV of PSUs of Ministry of Power, Govt. of India)
3rd Floor, Buddha Bhavan, Ranigunj,
Secunderabad- 500003
Telangana

Subject: -

Dear Sir,

1. With Reference to your subject IFB/RfP, we are pleased to submit our bid/proposal for“ ” in a sealed cover as detailed below:
2. Packet-I of Envelope 1:
 - a. **Bid document Fee:** Fee towards cost of RfP Documents as per clause ITB 1.4 or documentary evidence as mentioned in Annexure-II of RFP in support of exemptionof Document Fee.
 - b. **Bid Security Fee/Earnest Money Deposit:** In the form of Banker’s Cheque / Demand Draft drawn in favour of “Energy Efficiency Services Limited” or in the form of BankGuarantee as per prescribed format at **Attachment-2** in section 6 or documentaryevidence as mentioned in Annexure-II of RFP in support of exemption of BidSecurity/EMD.
3. Packet-II of Envelope 1:
 - a. Attachment 1: Bid Form
 - b. Attachment 2: Form for Submitting BG Format in Lieu of EMD
 - c. Attachment 3: Power of Attorney
 - d. Attachment 4: Certificate regarding acceptance of important terms and conditions
 - e. Attachment 5: Deviation statement
 - f. Attachment 6: Form of acceptance of EESL fraud prevention policy
 - g. Attachment 7: An undertaking by Holding Company (As Applicable).
 - h. Attachment 8: Format for details regarding RTGS/NEFT Payments
 - i. Attachment 9: Compliance Matrix/ Check - List for Bidders
 - j. Attachment 10: Certificate Regarding Declaration of Local Content
 - k. Attachment 11: “Restrictions on procurement from a Bidder of a country which shares a land border with India” Certification by the Bidder per order no. F.No.6/18/2019-PPD dated 23/07/2020 issued by Public Procurement Division, Department of Expenditure, Ministry of Finance, Government of India (DoE Order)
 - l. Attachment-12: Details regarding Qualifying Requirement /Eligibility criteria as per Part-B (BDS).
 - m. Attachment-13: Declaration duly signed on Company Letter Head Pad with company’s seal for not being under debar list/undergoing debarment period on account of breach of the code of integrity under rule 175(1)(i)(h) of general financial rules.
 - n. Attachment-14: Certificate regarding non debarment / blacklisting/disqualification

- o. Techno-commercial bid as indicated in bid document. Documentary evidence regarding bidder's qualifications to perform the contract as required in qualifying Requirement
- 4. Envelope 2: Price Bid (duly filled in electronic template as available on the e-portal).
- 5. We confirm that we have quoted as per instructions and terms and conditions of tender/RfP documents. Further, it is certified that in line with clause 1.1.2 of Section-2(ITB) no conflict of interest exists as on date and if in future such a conflict of interest arises, we will intimate the same.
- 6. We declare that the prices left blank in price schedule/price bid will be deemed to have been included in the prices of other items. We confirm that except as otherwise specifically provided, our bid prices include all applicable taxes & duties except applicable GST. The GST shall be paid extra at actual
- 7. We further declare that additional conditions, variations, deviations, if any, found in the proposal save those pertaining to any rebates offered, shall not be given effect to.
- 8. We undertake, if our bid is accepted, we shall commence the work immediately upon your Notification of Award to us, to achieve completion of work within the time specified in the bidding documents.
- 9. We agree to abide by this bid for a period Six Months from the date of opening of bids as stipulated in the RfP documents and it shall remain binding upon us and may be accepted by you at any time before the expiration of that period. Further, the prices of recommended spares, if asked for; contained in our bid shall remain valid for the entire project period after issuance of Notification of Award.
- 10. Until a formal contract is prepared and executed between us, this bid, together with your written acceptance thereof in the form of your Notification of Award shall constitute a binding contract between us.
- 11. We understand that you are not bound to accept the lowest or any other bid you may receive.
- 12. We declare that we are registered, as applicable, with ESIC, EPF and Miscellaneous Provisions Act 1952 and will comply with Employees Compensation Act, 1923 and Minimum Wages Act, 1948.
- 13. We, hereby, declare that only the persons or firms interested in this proposal as principals are named here and that no other persons or firms other than those mentioned herein have any interest in this proposal or in the contract to be entered into, if the award is made on us, that this proposal is made without any connection with any other person, firm or party likewise submitting a proposal, in all respects for and in good faith, without collusion or fraud.

NAME/S & AUTHORISED SIGNATORIES
 ADDRESS:
 MOBILE NO.:
 LAND LINE NO.:

Our correspondence details are:

NIT/Bid Document No.: EESL/06/24-25/SERC-Contracts/TS/CCMS - GHMC & ULB/OTE-232414, Date: 25/09/2024	SECTION -6 (Forms)	Page 6 of 74
--	-----------------------	--------------

1	Name of the bidder	
2	Address of the bidder	
3	Name of the contact person to whom all references shall be made regarding this tender	
4	Designation of the person to whom all references shall be made regarding this tender	
5	Address of the person to whom all references shall be made regarding this tender	
6	Telephone (with STD code)	
7	E-Mail of the contact person	
8	Fax No. (with STD code)	
9	GST No. of the bidder	

Form for Submitting BG Format in lieu of EMD

(To be stamped in accordance with Stamp Act, if any, of the country of the issuing Bank)

Bank Guarantee No.

Date.....

To:

Energy Efficiency Services Limited.
(A JV of PSUs of Ministry of Power, Govt. of India)
3rd Floor, Buddha Bhavan,
Ranigunj, Secunderabad – 500003
Telangana

Dear Sir(s),

In accordance with invitation for bids under your bidding document/ package no.....dated.....M/s.....having its registered/head office at.....(here in after called "Bidder") wish to participate in the said bid for (name of package)

We, the(Name and address of the bank), having our head office at guarantee and undertake to pay immediately on demand by Energy Efficiency Services Limited, the amount of without any reservation, protest, recourse. Any such demand made by the employer shall be conclusive and binding on us irrespective of any dispute or difference raised by the bidder.

The Guarantee shall be irrevocable and shall remain valid upto If any further extension of guarantee is required, the same shall be extended to such period (not exceeding one year) on receiving instructions from..... (Bidder's Name)_____, on whose behalf guarantee is issued.

In witness whereof the bank, through its authorized officer, has set its hand and stamp on this.....day of20.....at.....

Witness:

Signature: Signature:

Name: Name :

Official address: Designation with Bank Stamp

Authorized vide Power of Attorney no.Date

NOTE:

- Bid Security amount shall be as specified in the IFB/ITB.
- Complete mailing address of the Head Office of the Bank to be given. The bank guarantee validity date shall be forty-five (45) days after the last date for which the bid is valid.
- The Stamp Paper of appropriate value shall be purchased in the name of guarantee issuing Bank. The Bank Guarantee shall be issued on a stamp paper of value as applicable in the State of the issuing bank in India or the State of Delhi in India or the State of India from where the BG shall be operated, whichever is higher.
- While getting the Bank Guarantee issued, Bidders are required to ensure compliance to the Bank Guarantee Verification Check List. Further, Bidders are required to fill up this Form 16 and enclose the same with the Bank Guarantee.

BANK GUARANTEE CHECK LIST

1	Bank Guarantee No.	
2	Issuing Bank	
3	Nature of BG & No. of Pages	
4	Validity of BG	
5	Package Description	
6	Party & Contracts ref.	Name, Address, Tel, Fax, E-mail
7	Bank Reference	

CHECK LIST

Sl. No.	Details of Checks	YES/NO
a)	Is the BG on non-judicial Stamp Paper of appropriate value, as per Stamp Act ?	
b)	Whether date, purpose of purchase of stamp paper and name of the purchaser are indicated on the back of Stamp paper under the Signature of Stamp vendor? (The date of purchase of stamp paper should be not later than the date of execution of BG and the stamp paper should be purchased either in the name of the executing Bank or the party on whose behalf the BG has been issued. Also the Stamp Paper should not be older than six months from the date of execution of BG)	
c)	In case the BG has been executed on Letter Head of the Bank, whether adhesive Stamp of appropriate value has been affixed thereon?	
d)	Has the executing Officer of BG indicated the name, designation and Power of Attorney No. / Signing Power no. etc., on the BG ?	
e)	Is each page of BG duly signed / initiated by executants and whether stamp of Bank is affixed thereon? Whether the last page is signed with full particulars including two witnesses under seal of Bank as required in the prescribed proforma?	
f)	Does the Bank Guarantees compare verbatim with the proforma prescribed in the bid documents ?	
g)	In case of any changes in contents of text, whether changes are of minor/clerical nature (which in no way limits the right of EESL in any manner) ?	
h)	In case of deviations in text of BG, which materially affect the right of EESL, whether the changes have been agreed based on the opinion by Legal Department or BG I considered acceptable on the basis of opinion of law Department already available on the similar issue.	
i)	Are the factual details such as Bid Document No. NOA/LOA/Contact No., Contract Price, Percentage of Advance, Amount of BG and Validity of BG correctly mentioned in the BG ?	
j)	Whether overwriting / cutting if any on the BG have been properly authenticated under signature and seal of executant ?	
k)	Whether the BG has been issued by a Bank in line with the provisions of Bid / Contract documents ?	
l)	In case BG has been issued by a Bank other than those specified of Bid / Contract Documents, is the BG confirmed by a Bank in India acceptable as per Bid / Contract documents?	

LIST OF BANKS ACCEPTABLE FOR SUBMISSION OF BANK GUARANTEE FOR BIDSECURITY

SCHEDULED COMMERCIAL BANKS

A. SBI AND ASSOCIATES

Sl. No.	Name of Banks	Sl. No.	Name of Banks
1.	State Bank of India	5.	State Bank of Mysore
2.	State Bank of Bikaner and Jaipur	6.	State Bank of Patiala
3.	State Bank of Hyderabad	7.	State Bank of Saurashtra
4.	State Bank of Indore	8.	State Bank of Travancore

B. NATIONALISED BANKS

Sl. No.	Name of Banks	Sl. No.	Name of Banks
9.	Allahabad Bank	13.	Canara Bank
10.	Andhra Bank	14.	Central Bank of India
11.	Bank of India	15.	Corporation Bank
12.	Bank of Maharashtra	16.	Dena Bank
17.	Indian Bank	18.	Indian Overseas Bank
19.	Oriental Bank of Commerce	20.	Punjab National Bank
21.	Punjab & Sind Bank	22.	Syndicate Bank
23.	Union Bank of India	24.	United Bank of India
25.	UCO Bank	26.	Vijaya Bank
27.	Bank of Baroda		

C. SCHEDULED PRIVATE BANKS (INDIAN BANKS)

Sl. No.	Name of Banks	Sl. No.	Name of Banks
27.	Bank of Rajasthan	41.	Sangli Bank Ltd.
28.	Bharat Overseas Bank Ltd.	42.	South Indian Bank Ltd.
29.	Catholic Syrian Bank	43.	Tamilnadu Mercantile Bank Ltd.
30.	City Union Bank	44.	United Western Bank Ltd.
31.	Dhanalakshmi Bank	45.	ING Vysya Bank Ltd.
32.	Federal Bank Ltd.	46.	UTI Bank Ltd.
33.	Jammu & Kashmir Bank Ltd.	47.	S.B.I. Commercial & International Bank Ltd.
34.	Karnataka Bank Ltd.	48.	Ganesh Bank of Kurundwad Ltd.
35.	Karur Vysya Bank Ltd.	49.	INDUSIND Bank Ltd.
36.	Lakshmi Vilas Bank Ltd.	50.	ICICI Bank Ltd.
37.	Lord Krishna Bank Ltd.	51.	HDFC Bank Ltd.
38.	Nainital Bank Ltd.	52.	Centurion Bank of Punjab Limited
39.	Kotak Mahindra Bank	53.	Development Credit Bank Ltd.
40.	Ratnakar Bank Ltd.	54.	Yes Bank

D. SCHEDULED PRIVATE BANKS (FOREIGN BANKS)

Sl. No.	Name of Banks	Sl. No.	Name of Banks
55.	Abu Dhabi Commercial Bank Ltd.	71.	Sonali Bank
56.	ABN Amro Bank Ltd.	72.	Standard Chartered Bank
57.	American Express Bank Ltd.	73.	J.P Morgan Chase Bank
58.	Bank of America NA	74.	State Bank of Mauritius
59.	Bank of Bahrain& Kuwait	75.	Development Bank of Singapore
60.	Mashreq Bank	76.	Bank of Ceylon
61.	Bank of Nova Scotia	77.	Bank International Indonesia

62.	The Bank of Tokyo-Mitsubishi UFJ Limited.	78.	Arab Bangladesh Bank
63.	Calyon Bank	79.	Cho Hung Bank
64.	BNP Paribas	80.	China Trust Bank
65.	Barclays Bank	81.	Mizuho Corporate Bank Ltd.
66.	Citi Bank	82.	Krung Thai Bank
67.	Deutsche Bank	83.	Antwerp Diamond Bank N.V. Belgium
68.	The Hong Kong and Shanghai Banking Corporation Ltd.	84.	Internationale Nederlanden Bank N.V. (ING Bank)
69.	Oman International Bank	85.	Bank of China Ltd.
70.	Societe Generale		

E. PUBLIC SECTOR BANK

Sl. No.	Name of Banks	Sl. No.	Name of Banks
86.	IDBI Ltd.		

Tender Document No/Package No: Dated:

Package Details.....

POWER OF ATTORNEY

BIDDER TO ATTACH THE POWER OF ATTORNEY IN THEIR OWN FORMAT

Tender Document No/Package No: Dated:

Package Details.....

POWER OF ATTORNEY

BIDDER TO ATTACH THE POWER OF ATTORNEY IN THEIR OWN FORMAT

Tender Document No/Package No:

Dated:

(CERTIFICATE REGARDING ACCEPTANCE OF IMPORTANT CONDITIONS)

Bidder's Name& Address

To,
 Additional General Manager (Contracts)
 Energy Efficiency Services Limited.
 (A JV of PSUs of Ministry of Power, Govt. of India)3rd floor, Buddha Bhavan,
 Ranigunj,
 Secunderabad - 500003
 Telangana

Sub:

With reference to our bid proposal no.....
 dated for /
 Package no dated, we hereby confirm that we have
 read the following provisions of the following clauses and further confirm that notwithstanding anything
 stated elsewhere to the contrary, the stipulation of these clauses are acceptable to us and we have not
 taken any deviation to these clauses.

- Governing Laws - Clause 5 of GCC
- Settlement of Disputes - Clause 6 of GCC
- Terms of payment - Clause 12 of GCC
- Performance Security - Clause 13.3 of GCC
- Taxes and Duties - Clause 14 of GCC
- Completion Time Guarantee - Clause 26 of GCC
- Defects Liability - Clause 27 of GCC
- Functional Guarantee - Clause 28 of GCC
- Patent Indemnity - Clause 29 of GCC
- Limitations of Liability - Clause 30 of GCC
- Project information, Estimation, - As per Tables in price bid Assumptions and conditions for
 Evaluation

We further confirm that any deviation to the above clauses found anywhere in our bid proposal, implicit or explicit, shall stand unconditionally withdrawn, without any implication to EESL.

Date:

Signature:

Place:

Printed Name:

Designation:

Common Seal

NAME OF WORK:
 BIDDING DOCUMENT NO.

(Deviations Statement)

Bidder's Name and Address:

To,
 Additional General Manager (Contracts)
 Energy Efficiency Services Limited.
 (A JV of PSUs of Ministry of Power, Govt. of India) 3rd floor, Buddha Bhavan,
 Ranigunj, Secunderabad - 500003
 Telangana

Dear Sir,

The following are the deviations and variations from and exceptions to the terms, conditions and specification of the bidding documents for IFB/RfP No. **EESL/06/24-25/SERC-Contracts/SLNP/TS/67ULB/DIC/R&M/OTE-242501** Date: . These deviations and variations are exhaustive. We are furnishing below the cost of withdrawal for the deviations and variations stated in this Attachment. We shall withdraw the deviations proposed by us in this Attachment at the cost of withdrawal indicated herein, failing which our bid may be rejected and bid security may be forfeited. We confirm that except for these deviations and variations, the entire work shall be performed as per your specifications and conditions of bidding documents. Further, we agree that additional conditions, variations, deviations if any, found in the proposal documents other than those stated in this Attachment, save those pertaining to any rebates offered, shall not be given effect to:

Section/ Clause	Page	Statement of	Cost of withdrawal
Part/ No.	No.	Deviations/	
Chapter		Variations	

A. COMMERCIAL DEVIATIONS:

B. TECHNICAL DEVIATIONS:

Date:

(Signature).....

Place:

(Printed Name).....

(Designation).....

(Common Seal)

Note: Continuations sheets of like size and format may be used as per Bidder's requirement.

**FORM OF ACCEPTANCE OF FRAUD PREVENTION POLICY
(On the letter head)**

To:

Additional General Manager (Contracts)
Energy Efficiency Services Limited.
(A JV of PSUs of Ministry of Power, Govt. of India)3rd floor, Buddha Bhavan,
Ranigunj, Secunderabad - 500003
Telangana

Sub: Letter of Acceptance of EESL Fraud Policy.

Ref: NIT/RFP No.: **EESL/06/24-25/SERC-Contracts/SLNP/TS/XX** **Date:**

Dear Sir/Madam,

We have read the contents of the Fraud Prevention Policy of EESL and undertake that wealong with our associate / collaborator / sub-contractors / sub-vendors / bidders/ serviceproviders shall strictly abide by the provisions of the Fraud Prevention Policy of EESL.

Thanking You,

Yours faithfully,

Signature

Printed Name

Designation.....

Common Seal.....

Date:

Place:

FOR DETAILED POLICY, PLEASE VISIT OUR WEBSITE www.eeslindia.org

PROFORMA OF LETTER OF UNDERTAKING

(TO BE FURNISHED ON NON-JUDICIAL STAMP PAPER OF APPROPRIATE VALUE)

[To be executed by the Holding Company Supported by Board Resolution and submitted by the Bidder along with the Bid, in case financial support is being extended by the Holding Company to the Bidder for meeting the stipulated Financial Qualifying]

Ref.: NIT/Bid Document No.:

Our Reference NoDate:

Bidder's Name and Address:

To,

Additional General Manager (Contracts)
Energy Efficiency Services Limited.
(A JV of PSUs of Ministry of Power, Govt. of India)3rd floor, Buddha Bhavan,
Ranigunj, Secunderabad - 500003
Telangana

Dear Sir,

1. We, M/s..... (Name of the Holding Company) declare that we are the holding company of M/s (Name of the Bidder) and have controlling interest therein.

M/s..... (Name of the Bidder) proposes to submit the bid for the package..... (Name of the package) for (Name of the Project) under bid reference no..... dated and have sought financial strength and support from us for meeting the stipulated Financial Qualifying Requirement as per Clause Section 3 and its subsequent amendment.

2. We hereby undertake that we hereby pledge our unconditional & irrevocable financial support for the execution of the said package to M/s..... (Name of the Bidder), for the execution of the Contract, in case they are awarded the Contract for the said package at the end of the bidding process. We further agree that this undertaking shall be without prejudice to the various liabilities that M/s (Name of Bidder) would be required to undertake in terms of the Contract including the Performance Security as well as other obligations of M/s (Name of the Bidder).

3. This undertaking is irrevocable and unconditional, and shall remain in force till the successful execution and performance of the entire contract and/or till it is discharged by EESL.
4. We are herewith enclosing a copy of the Board Resolution in support of this undertaking.

Yours faithfully,

(Signature of Authorized Signatory) on behalf of the Holding Company

Witness:

1.
2.

Name & Designation

Name of the Holding Company
(Seal of Holding Company)

**REAL TIME GROSS SETTLEMENT (RTGS)/ NATIONAL ELECTRONIC FUND TRANSFER
(NEFT)**

From: M/s

Sub: RTGS/NEFT Payments

We are agree to accept admissible payments through electronic mode viz RTGS/NEFT. For this, we are providing the requisite information herein below. The RTGS/NEFT charges for the above facility may be deducted/Recovered from our admissible payment.

Name Of City	
Bank Code No.	
Branch Code No.	
Bank's Name	
Branch Address	
Branch Telephone/ Fax No.	
Supplier Account No.	
Type of Account	
IFSC Code for NEFT	
IFSC Code for RTGS	
Supplier's name as per Account	
Telephone No. of Supplier	
Supplier's E-mail ID	
GSTIN of Supplier	
PAN No. of Supplier	

A cancelled cheque against above bank account number is also being enclosed.

Encl: As above: -

Confirmed by Banker
With Seal

Signature of supplier
With stamp & Address

Compliance Matrix/ CHECK - LIST FOR BIDDERS

Please ensure these major Terms & Conditions before submitting you bids in order to avoid REJECTION of your offer.

Sr. No.	Detail/Terms & Conditions	Applicable For	Attached		Reasons for non-compliance/remarks
			Yes	No	
1	Bid Fee (If Applicable)	Indian Bidders			
2	EMD (If Applicable)	Indian Bidders			
3	Bid Fee exempted for being MSE/ Start-up	Indian Bidders			
	EMD exempted for being MSE/Start-up	Indian Bidders			
	In case of claiming exemption in submission of Bid Fee and EMD, Relevant Certificate of MSEs/Start-up certificate from DIPP (Refer Section-2) is required to be submitted (registration to be for item tendered in accordance with NIC codes defined under Clause 6 of SCC in Section-4)	Indian Bidders			
	In case of claiming exemption in submission of Bid Fee and EMD, enclose proof of being a manufacturer of tendered item or Declaration as per Attachment-15 of Section-6 (as applicable). Relevant document issued by competent Govt. Authority/ Body shall be submitted. Refer 'Important Note' under Clause-6 of SCC in Section-4	Indian Bidders			
	In case of Start-up, Business Eligibility certificate (for item tendered) is also required to be submitted (Refer Page 12 of Section-2)	Indian Bidders			
	In case of SC/ST entrepreneurs belonging to MSE, documentary proof to be submitted	Indian Bidders			
	In case of Women entrepreneurs belonging to MSE, documentary proof to be submitted	Indian Bidders			

4	Duly signed and company sealed copy of whole tender document and subsequent amendments (if any)	IndianBidders			
5	Duly filled up and attached Technical(Unpriced) Bid and all applicable formats of tender document.	IndianBidders			
6	Acceptance of important terms and conditions in line with ITB clause 4.6 as per format attached as Attachment-4,	IndianBidders			
7	Separate sheet(s) of deviation (Attachment-5) If any, from the tender conditions with seal and signature of authorized personnel.	IndianBidders			
8	Form of acceptance of EESL fraud prevention policy and declaration as per Attachment- 6	IndianBidders			
9	CERTIFICATE REGARDING DECLARATION OF LOCAL CONTENT (As per Attachment 10 of The tenderdocument)	IndianBidders			
10	Certification by the Bidder per order no. F.No.6/18/2019-PPD dated 23/07/2020 issued by Public Procurement Division, Department of Expenditure, Ministry of Finance, Government of India (DoE Order) (as per format in Attachment -11 of Section-6)	IndianBidders			
11	GST Registration Certificate and PAN Card Copy.	IndianBidders			

NOT TO BE PRINTED ALONG WITH ABOVE TABLE

The above mentioned points are major Terms & Conditions and are indicative in nature. Bidders shall carefully go through the detailed requirements, QR and other terms and conditions for better understanding and submit the bid accordingly.

Format for Affidavit of Self certification regarding Local Content in line with PPP-MII order and MoP Order, if applicable, to be provided on a non-judicial stamp paper of Rs. 100/-.

Name of the Tender:

Date:

I _____ S/o, D/o, W/o, _____ Resident of _____ hereby solemnly affirm and declare as under:

That I will agree to abide by the terms and conditions of the Public Procurement (Preference to Make in India) Order, 2017 of Government of India issued vide Notification No: P-45021/2/2017-BE-II dated 15/06/2017, its revision dated 16/09/2020 (hereinafter PPP-MII order),

'Public Procurement (Preference to Make in India) to provide for Purchase Preference (linked with local content)' order dated 16/11/2021 issued by Ministry of Power (hereinafter MoP order) and any subsequent modifications/Amendments, if any and

That the information furnished hereinafter is correct to the best of my knowledge and belief and I undertake to produce relevant records before the procuring entity/EESL or any other Government authority for the purpose of assessing the local content of goods/services/works supplied by me for

That the local content for all inputs which constitute the said goods/services/works has been verified by me and I am responsible for the correctness of the claims made therein.

That the 'Local Content' as defined in the PPP-MII order and MoP order in the goods/ services/ works supplied by me for is percent (%).

That the goods/ services/ works supplied by me for, meet the 'Local Content' requirement as defined in the PPP-MII order **and MoP order for 'Class -I local supplier'**.

That the value addition for the purpose of meeting the 'Local Content' has been made by me at (Enter the details of the location(s) at which value addition is made).

That in the event of the local content of the goods/services/works mentioned herein is found to be incorrect and not meeting the prescribed Local Content criteria, based on the assessment of procuring agency (ies)/EESL/Government Authorities for the purpose of assessing the local content, action shall be taken against me in line with the PPP-MII order, **MoP order** and provisions of the Integrity pact/ Bidding Documents.

I agree to maintain the following information in the Company's record for a period of 8 years and shall make this available for verification to any statutory authority.

- i. Name and details of the Local Supplier (Registered Office, Manufacturing unit location, nature of legal entity)
- ii. Date on which this certificate is issued
- iii. Goods/services/works for which the certificate is produced
- iv. Procuring entity to whom the certificate is furnished
- v. Percentage of local content claimed and whether it meets the Local Content prescribed for 'Class -I local supplier'
- vi. Name and contact details of the unit of the Local Supplier (s)
- vii. Sale Price of the product
- viii. Ex-Factory Price of the product
- ix. Freight, insurance and handling
- x. Total Bill of Material
- xi. List and total cost value of input used to manufacture the Goods/to provide services/in construction of works
- xii. List and total cost of input which are domestically sourced. Value addition certificates from suppliers, if the input is not in-house to be attached
- xiii. List and cost of inputs which are imported, directly or indirectly

For and on behalf of (Name of firm/entity)

Authorized signatory (To be duly authorized by the Board of Directors)

<Insert Name, Designation and Contact No.>

Certificate from statutory auditor or cost auditor of the company (in the case of companies) or from a practicing cost accountant or practicing chartered accountant (in respect of suppliers other than companies) giving the percentage of Local Content, in line with PPP-MII order and MoP order, if applicable [to be submitted on the letter head of the issuer.]

Dear Sir,

We have read and understood the provisions of “Public Procurement (Preference to Make in India) Order, 2017” dated 15/06/2017, its revision dated **16/09/2020** [hereinafter, “PPP-MII Order”] issued by **Department for promotion of Industry and Internal Trade (DPIIT)**, Ministry of Commerce and Industry, Government of India,

‘Public Procurement (Preference to Make in India) to provide for Purchase Preference(linked with local content)’ order dated 16/11/2021 issued by Ministry of Power [hereinafter, “MoP order”]

and any subsequent modifications/Amendments, if any.

In line with the provisions of the PPP-MII Order **and MoP Order**, M/s[Enter the name of the Bidder] [hereinafter, “**Class-I Local Supplier**” have submitted an Affidavit of self-certification to M/s. Energy Efficiency Services Limited [hereinafter, EESL] regarding Local Content in Goods/Services/Works to be supplied by the “**Class-I Local Supplier**” for, wherein they have agreed to abide by the terms and conditions of the PPP-MII Order **and MoP Order**.

Further, in line with the PPP-MII Order, the statutory auditor or cost auditor of the company (**in the case of companies**) or a practicing cost accountant or practicing chartered accountant (**in respect of suppliers other than companies**) shall provide a certificate giving the percentage of Local Content in the Goods/Service/Works to be supplied by the “**Class-I Local Supplier**” for.....

Accordingly, we, the Statutory Auditor(s) / Cost auditor of the “**Class-I Local Supplier**” a practicing cost accountant or practicing chartered accountant [*choose as applicable*], certify that the Local Content as defined under the PPP-MII **and MoP Order**, in the Goods/Service/Works to be supplied by the “**Class-I Local Supplier**” or for is percentage [*specify the percentage of Local content*].

For and on behalf of,

Date:

<<Statutory Auditor’s/Cost auditor’s/Cost accountant’s/Chartered accountant’s attestation>>

Firm Reg No.

Membership No.

Note: This is a guiding format. In case the bidder submits the certificate in a format different from the above, the same may be considered provided it meets the intent and purpose, as may be ascertained by EESL.

Certification by the Bidder as per order no. F.No.6/18/2019-PPD dated 23/07/2020 issued by Public Procurement Division, Department of Expenditure, Ministry of Finance, Government of India (DoE Order)

1. We have read and understood the provisions of Order no. F.No.6/18/2019-PPD (Order Public Procurement no.1) dated 23/07/2020 regarding "Restriction under Rule 144(xi) of General Financial Rules" and F.No.6/18/2019-PPD (Order Public Procurement no.2) dated 23/07/2020 regarding "Exclusions from Restriction under Rule 144(xi) of General Financial Rules" issued by Public Procurement Division, Department of Expenditure, Ministry of Finance, Government of India [hereinafter collectively "DoE Order"] and any subsequent modifications/Amendments, if any.
2. Particularly, we, the Bidder, have read the clause regarding restrictions on procurement from a 'Bidder of a country which shares a land border with India' and on sub-contracting to contractors from such countries.
3. We certify that we, the bidder is not from such a country or, if from such a country, has been registered **as per provisions of the requisite Order/Circular/Document** with the Competent Authority and will not subcontract any work to a subcontractor/sub vendor from such countries unless such subcontractor/subvendor fulfils all requirement in this regard and is eligible to be considered. [*Where applicable, evidence of valid registration by the Competent Authority shall be attached.*]
4. We further declare that any misrepresentation or submission of false/forged document/information in this regard shall be dealt with as per the provisions of RfP Documents and/or EESL's policy and procedures.

Date:

Printed Name:

Place:

Designation:

Format for filling details related to Eligibility Conditions and Qualifying Requirement (QR):

(This format is required to be submitted by the Bidder along with data/details/documents submitted in support of meeting criteria for eligibility conditions and QR)

Eligibility Conditions		
Sl. No.	Details	Declaration by the Bidder (Declare/Tick (✓) whichever is applicable)
1.	Status of the Bidder	
a.	Single Entity means a limited company (as defined in the Companies Act, 1956)	<input type="checkbox"/>
b.	A registered partnership firm (registered under section 59 of the Partnership Act, 1932)	<input type="checkbox"/>
c.	A limited liability partnership (under the Limited Liability Partnership Act, 2002)	<input type="checkbox"/>
1.1	Details of Documents submitted as evidence for aforesaid status	(...fill in no. and date of Documentary evidence....)
2.	<p>PPP MII guidelines issued by Govt. of India shall be applicable for this tender.</p> <p>Only Class-I Local Suppliers with 60% minimum local content are eligible to bid in this tender in conformance with the order for "Public procurement (Preference to make in India) to provide for Purchase preference (linked with local content) in respect of Power sector" issued vide ref no. A-1/2021-FSC-Part (5) GoI, MOP Dated 16.11.2021</p> <p>NOTE: - Only Class-I suppliers as defined in the above tender are eligible to take part in this bidding process.</p>	<p>Attachment 10 is attached</p> <p>Yes</p> <p>No</p>
3.	<p>Pursuant to Order No. F. No 6/18/2019-PPD dated-23-July-2020 from Department of Expenditure, Ministry of Finance, the applicant should be either of the following:</p> <ul style="list-style-type: none"> - Not from a country which shares a land border with India - OR 	<p>Attachment 11 is attached</p> <p>Yes</p> <p>No</p>

	<p>- Applicant from a country which shares a land border with India and registered with Competent Authority in accordance with order mentioned above.</p> <p>The definition of "Bidder" from a country which shares a land border with India shall be as in paragraph 8 of the above mentioned order. Further, all the guidelines mentioned to this above order shall be applicable to this Tender. Bidder shall carefully go through the same and ensure its eligibility as per the said order.</p>	
4.	Not to be blacklisted by Central/State/UT Government or any Public sector entities for the tender item/work duly signed and stamped at company's Letter Head.	Submitted in line with QR Yes No

Qualifying Requirement		
Sl. No.	Details	Declaration by the Bidder (Declare/Tick (√) whichever is applicable)
1.1.1	Mention no. and date of Contract for which Documentary Evidence is attached in respect of work experience for 'Similar Assignments' in line with the QR	(...fill details in line with QR)
a)	Mention Name and Address of Client along with Contact details of concerned person	(...fill in requisite details....)
b)	<p>Whether Scope of Work under above referred Contract at sl. no. 1.1.1 includes below mentioned similarwork:</p> <p>"Similar work" means Bidder should have experience in project execution or Repair & Maintenance work of Distribution Line /LT Cable/ Overhead Cable work/ CCMS installation, repair & maintenance or experience of installation and commissioning of electrical infrastructure in any industrial Plant, Institutional areas or ULB/ SITC job of IDC items as aske in the tender document OR street light maintenance OR any project related to power sector infrastructure development in any power distribution utilities/ DISCOMs/ ULBs or any other govt. organization.</p> <p>The work "executed" mentioned above means the bidder should have achieved the criteria specified above even if the total contract is started earlier and/or is not completed / closed. However, the work executed / completed must include "Similar work" as above.</p> <p>In case of orders under execution, the value of work executed till the date of opening of Techno- Commercial proposal as certified by the Client shall be considered. However, the work executed must include "Similar work" as above.</p>	<p>Yes <input type="checkbox"/></p> <p>No <input type="checkbox"/></p>
c)	Value of Work Order
d)	Date of execution/completionDD/MM/YYYY...

Note: Use separate sheets for each Contract to fill in details as per sl. No.1.1.1 above

Sl. No.	Details	Declaration by the Bidder <i>(Declare/Tick (✓) whichever is applicable)</i>
1.2.1	Average Annual Turnover (ATO) during the last 03 Financial Years (i) Financial Year 1 (ii) Financial Year 2 (iii) Financial Year 3	INR..... INR..... INR.....
1.2.2	Liquid Assets (L.A) as on 31st March of last available Year.	INR.....
1.2.3	The net worth of the bidder in immediate last financial year should not be less than 100% of paid-up share capital or capital. Net worth of partnership Net Worth may be considered negative in case closing capital of immediately preceding year is less than average closing capital of previous 3 financial years including immediate preceding year.	INR.....

I hereby declare that data/details as filled-in hereinabove are true and correct, in case of any misrepresentation by us suitable action may be taken by EESL as per the provision of RfP Documents and EESL's Policy and Guidelines.

Signature:

Name:

Designation:

For and on behalf of M/s.....

**CERTIFICATE REGARDING NON- DEBARMENT FOR FALSE DECLARATION OF LOCAL
CONTENT
[On the Letter Head]**

To,
Additional General Manager (Contracts)
Energy Efficiency Services Limited.
(A JV of PSUs of Ministry of Power, Govt. of India)
3rd Floor, Buddha Bhavan, Ranigunj, Secunderabad - 500003,
Telangana

Sub: Certificate regarding Non-debarment for false declaration of Local Content
Ref: NIT/Bid Document No:

Dear Sir/Madam,

We certify that we are not under debar list/undergoing debarment period on account of breach of the code of integrity under rule 175(1)(i)(h) of General Financial Rules for giving false declaration of local content.

Thanking You,

Yours faithfully,

Signature.....

Printed Name.....

Seal.....

Date:

Place:

CERTIFICATE REGARDING NON DEBARMENT / BLACKLISTING/DISQUALIFICATION
[On the Letter Head]

To,
Additional General Manager (Contracts)
Energy Efficiency Services Limited.
(A JV of PSUs of Ministry of Power, Govt. of India)
3rd Floor, Buddha Bhavan, Ranigunj, Secunderabad - 500003
Telangana

Sub: Certificate regarding non debarment / blacklisting/ disqualification
Ref: NIT/Bid Document No:

Dear Sir/Madam,

We certify that we have not been black-listed/debarred/dis-qualified by any regulatory/ statutory body/ Central/State/UT Government or any Public sector entities for tendered services. We further certify that we have read the contents of the Fraud Prevention Policy of EESL (available on website of EESL i.e. www.eeslindia.org) and undertake that we along with our associate / collaborator / sub-contractors / sub-vendors / bidders/ service providers shall strictly abide by the provisions of the Fraud Prevention Policy of EESL.

Thanking You,

Yours faithfully,

Signature.....

Printed Name.....

Seal.....

Date:

Place:

(On Non - Judicial Stamp Paper of appropriate value and purchased in the name of executing Bank)

PROFORMA OF BANK GUARANTEE FOR CONTRACT PERFORMANCE

Ref.:
Bank Guarantee No.....
Date.....

To,
Additional General Manager (Contracts)
Energy Efficiency Services Limited.
(A JV of PSUs of Ministry of Power, Govt. of India)
3rd Floor, Buddha Bhavan, Ranigunj, Secunderabad - 500003
Telangana

Dear Sirs,

In consideration of the EESL, (hereinafter referred to as the 'Owner,' which expression shall unless repugnant to the context or meaning thereof include its successors, administrators and assigns) having awarded to M/s.....with its Registered / Head Office at (hereinafter referred to as the 'Contractor', which expression shall unless repugnant to the context or meaning thereof, include its successors, administrators and assigns), a Contract by issue of Owner's Letter of Award No.....dated..... and the same having been unequivocally accepted by the Contractor and the contractor (Scope of Contract) having agreed to provide a Contract Performance Guarantee for the faithful performance of the entire Contract equivalent to *.....% (percent) of the said value of the Contract to the Owner.

We(Name & address) having its Head Office at.....(hereinafter referred to as the 'Bank', which expression shall, unless repugnant to the context or meaning thereof, include its successors administrators, executors and assigns) do hereby guarantee and undertake to pay the Owner, on demand any all money payable by the Contractor to the extent of as aforesaid at any time up to (days/months/year) without any demur, reservation, contest, recourse or protest and / or without any reference to the Contractor. Any such demand made by the Owner on the Bank shall be conclusive and binding notwithstanding any difference between the Owner and the Contractor or any dispute pending before any court, tribunal, Arbitrator or any other authority. The Bank undertakes not to revoke this guarantee during its currency without previous consent of the Owner and further agrees that the guarantee herein contained shall continue to be enforceable till the owner discharges this guarantee.

The owner shall have the fullest liberty without affecting in any way the liability of the Bank under this guarantee from time to time to extent the time for performance of the Contract by the Contractor. The owner shall have the fullest liberty, without affecting this guarantee, to postpone from time to time the exercise of any powers vested in them or of any right which they to enforce or to forbear to enforce any covenants, contained or implied, in the Contract between the owner and Contractor or any other course of or remedy or security available to the owner. The Bank shall not be released of its obligations under these presents by any exercise by the owner of its liberty with reference to the matters aforesaid on any of other

indulgence shown by the owner or by any other matter or thing whatsoever which under law would, but for this provision, have the effect of relieving the Bank.

The Bank also agree that the Owner at its option shall be entitled to enforce this Guarantee against the Bank as a Principal debtor, in the first instance without proceeding against the Contractor and not withstanding any security or other guarantee that the owner may have in relation to the Contractor's liabilities.

Notwithstanding anything contained herein above our liability under this guarantee is restricted to.....and it shall remain in force up to and including** and shall be extended from time to time for such period (not exceeding one year), as may be desired by M/s.....on whose behalf this guarantee has been given.

Witness

Dated thisday of.....at.....

Witness

Signature.....

Name.....

Official Address

Signature.....

Bank's Rubber Stamp

Name.....

Designation with Bank Stamp

Attorney as per power of Attorney

No.....dated.....

*Note: ** Validity of Bank Guarantee should be 90 days in excess of the period for which it is required.*

BANK GUARANTEE

CHECK LIST

1	Bank Guarantee No.	
2	Issuing Bank	
4	Nature of BG & No. of Pages	
5	Validity of BG	
6	Package Description	
7	Party & Contracts ref.	Name, Address, Tel, Fax, E – mail
8	Bank Reference	

<u>Check List</u>		
Sl. No.	Details of Checks	YES/ NO
a)	Is the BG on non-judicial Stamp Paper of appropriate value, as per Stamp Act ?	
b)	Whether date, purpose of purchase of stamp paper and name of the purchaser are indicated on the back of Stamp paper under the Signature of Stamp vendor? (The date of purchase of stamp paper should be not later than the date of execution of BG and the stamp paper should be purchased either in the name of the executing Bank or the party on whose behalf the BG has been issued. Also the Stamp Paper should not be older than six months from the date of execution of BG)	
c)	In case the BG has been executed on Letter Head of the Bank, whether adhesive Stamp of appropriate value has been affixed thereon?	
d)	Has the executing Officer of BG indicated the name, designation and Power of Attorney No./ Signing Power no. etc., on the BG?	
e)	Is each page of BG duly signed / initiated by executants and whether stamp of Bank is affixed thereon? Whether the last page is signed with full particulars including two witnesses under seal of Bank as required in the prescribed proforma?	
f)	Does the Bank Guarantees compare verbatim with the Proforma prescribed in the Bid Documents?	
g)	In case of any changes in contents of text, whether changes are of minor / clerical nature (which in no way limits the right of EESL in any manner)?	
h)	In case of deviations in text of BG, which materially affect the right of EESL, whether the changes have been agreed based on the opinion by Legal Department or BG I considered acceptable on the basis of opinion of law Department already available on the similar issue.	
i)	Are the factual details such as Bid Document No. NOA/LOA / Contact No., Contract Price, Percentage of Advance, Amount of BG and Validity of BG correctly mentioned in the BG?	
j)	Whether overwriting / cutting if any on the BG have been properly authenticated under signature and seal of executant?	
k)	Whether the BG has been issued by a Bank in line with the provisions of Bid / Contract documents?	
l)	In case BG has been issued by a Bank other than those specified of Bid / Contract Documents, is the BG confirmed by a Bank in India acceptable as per Bid / Contract documents?	

LIST OF BANKS ACCEPTABLE FOR SUBMISSION OF BANK GUARANTEES FOR ADVANCE PAYMENTS, PERFORMANCE SECURITIES AND SECURITIES FOR DEED OF JOINT UNDERTAKING

SCHEDULED COMMERCIAL BANKS

1. SBI AND ASSOCIATES

Sl. No.	Name of Banks	Sl. No.	Name of Banks
1.	State Bank of India	5.	State Bank of Mysore
2.	State Bank of Bikaner and Jaipur	6.	State Bank of Patiala
3.	State Bank of Hyderabad	7.	State Bank of Saurashtra
4.	State Bank of Indore	8.	State Bank of Travancore

2. NATIONALISED BANKS

Sl. No.	Name of Banks	Sl. No.	Name of Banks
9.	Allahabad Bank	13.	Canara Bank
10.	Andhra Bank	14.	Central Bank of India
11.	Bank of India	15.	Corporation Bank
12.	Bank of Maharashtra	16.	Dena Bank
17.	Indian Bank	18.	Indian Overseas Bank
19.	Oriental Bank of Commerce	20.	Punjab National Bank
21.	Punjab & Sind Bank	22.	Syndicate Bank
23.	Union Bank of India	24.	United Bank of India
25.	UCO Bank	26.	Vijaya Bank
27.	Bank of Baroda		

3. SCHEDULED PRIVATE BANKS (INDIAN BANKS)

Sl. No.	Name of Banks	Sl. No.	Name of Banks
27.	Bank of Rajasthan	41.	Sangli Bank Ltd.

28	Bharat Overseas Bank Ltd.	42.	South Indian Bank Ltd.
29.	Catholic Syrian Bank	43.	Tamilnadu Mercantile Bank Ltd.
30.	City Union Bank	44.	United Western Bank Ltd.
31.	Dhanalakshmi Bank	45.	ING Vysya Bank Ltd.
32.	Federal Bank Ltd.	46	UTI Bank Ltd.
33.	Jammu & Kashmir Bank Ltd.	47.	S.B.I. Commercial &International Bank Ltd.
34.	Karnataka Bank Ltd.	48.	Ganesh Bank of Kurundwad Ltd.
35.	Karur Vysya Bank Ltd.	49.	INDUSIND Bank Ltd.
36.	Lakshmi Vilas Bank Ltd.	50.	ICICI Bank Ltd.
37.	Lord Krishna Bank Ltd.	51.	HDFC Bank Ltd.
38.	Nainital Bank Ltd.	52.	Centurion Bank of Punjab Limited
39.	Kotak Mahindra Bank	53.	Development Credit Bank Ltd.
40.	Ratnakar Bank Ltd.	54.	Yes Bank

4. SCHEDULED PRIVATE BANKS (FOREIGN BANKS)

Sl. No.	Name of Banks	Sl. No.	Name of Banks
55.	Abu Dhabi Commercial Bank Ltd.	71.	Sonali Bank
56.	ABN Amro Bank Ltd.	72.	Standard Chartered Bank
57.	American Express Bank Ltd.	73.	J.P Morgan Chase Bank
58.	Bank of America NA	74.	State Bank of Mauritius
59	Bank of Bahrain& Kuwait	75.	Development Bank of Singapore
60.	Mashreq Bank	76.	Bank of Ceylon
61.	Bank of Nova Scotia	77.	Bank International Indonesia
62.	The Bank of Tokyo-Mitsubishi UFJ Limited.	78.	Arab Bangladesh Bank
63.	Calyon Bank	79.	Cho Hung Bank
64.	BNP Paribas	80.	China Trust Bank

65.	Barclays Bank	81.	Mizuho Corporate Bank Ltd.
66.	Citi Bank	82.	Krung Thai Bank
67.	Deutsche Bank	83.	Antwerp Diamond Bank N.V. Belgium
68.	The Hong Kong and Shanghai Banking Corporation Ltd.	84.	Internationale NetherlandenBank N.V. (ING Bank)
69.	Oman International Bank	85.	Bank of China Ltd.
70.	Societe Generale		

5. PUBLIC SECTOR BANK

Sl. No.	Name of Banks	Sl. No.	Name of Banks
86.	IDBI Ltd.		

FORM OF UNDERTAKING BY THE JOINT VENTURE PARTNERS (If Applicable)
(On Non-Judicial Stamp Paper of Appropriate Value if required)

THIS JOINT DEED OF UNDERTAKING executed on this..... day of..... Two Thousand and..... by a company incorporated under the laws of and having its Registered Office at (hereinafter called the "Party No.1" which expression shall include its successors, executors and permitted assigns) and M/s.....a company incorporated under the laws of.....and having its Registered Office at..... hereinafter called the "Party No.2" which expression shall include its successors, executors and permitted assigns) for the purpose of making a bid and entering into a contract [hereinafter called the "Contract" {in case of award)] against the NIT/ICB No.....for (insert name of the Tender) of Energy Efficiency Services Limited, a Company incorporated under the Companies Act of 1956 having its registered office at NFL Building, 5th & 6th Floor, Core - III, SCOPE Complex, Lodhi Road, New Delhi - 110003 (hereinafter called the "Purchaser").

WHEREAS the Party No.1 and Party No.2 have entered into an Agreement dated

AND WHEREAS the Purchaser invited bids as per the above mentioned Specification for the design, manufacture, Supply of Equipment Materials stipulated in the bidding documents under subject Tender i.e.....

AND WHEREAS Clause 19, Section-ITB and BDS (documents establishing the Qualification of Bidder) & Qualification Criteria in Section-3 forming part of the bidding documents, inter- alia stipulates that an Undertaking of two qualified manufacturers as partners, meeting the requirements of Qualification Criteria in Section-3, as applicable may bid, provided, the Joint Venture fulfils all other requirements under Clause 4 of ITB and Qualification Criteria in Section-3 and in such a case, the Bid Submission Sheets shall be signed by all the partners so as to legally bind all the Partners of the Joint Venture, who will be jointly and severally liable to perform the Contract and all obligations hereunder.

The above clause further states that this Undertaking shall be attached to the bid and the Contract performance guarantee will be as per the format enclosed with the bidding document without any restrictions or liability for either party.

AND WHEREAS the bid is being submitted to the Purchaser vide proposal No..... dated.....by Party No.1 based on this Undertaking between all the parties; under these presents and the bid in accordance with the requirements of Clause 19, Section-ITB and BDS (documents establishing the Qualification of Bidder) & Qualification Criteria in Section-3, has been signed by all the parties.

NOW THIS UNDERTAKING WITNESSETH AS UNDER:

In consideration of the above premises and agreements all the parties of this Deed of Undertaking do hereby declare and undertake:

- 1. In requirement of the award of the Contract by the Purchaser to the Joint Venture Partners, we, the Parties do hereby undertake that M/s..... the Party No.1, shall act as Lead Partner and further declare and confirm that we the parties to the Joint Venture shall jointly and severally be bound unto the Purchaser for the successful performance of the Contract and shall be fully responsible for

the design, manufacture, Supply, and successful performance of the equipment in accordance with the Contract:

2. In case of any breach or default of the said Contract by any of the parties to the Joint Venture, the party(s) do hereby undertake to be fully responsible for the successful performance of the Contract and to carry out all the obligations and responsibilities under the Contract in accordance with the requirements of the Contract.
3. Further, if the Purchaser suffers any loss or damage on account of any breach in the Contract or any shortfall in the performance of the equipment in meeting the performances guaranteed as per the specification in terms of the Contract, the Party(s) of these presents undertake to promptly make good such loss or damages caused to the Purchaser, on its demand without any demur. It shall not be necessary or obligatory for the Purchaser to proceed against Lead Partner to these presents before proceeding against or dealing with the other Party(s), the Purchaser can proceed against any of the parties who shall be jointly and severally liable for the performance and all other liabilities/obligations under the Contract to the Purchaser.
4. The financial liability of the Parties of this Deed of Undertaking to the Purchaser, with respect to any of the claims rising out of the performance or non-performance of the obligations set forth in this Deed of Undertaking, read in conjunction with the relevant conditions of the Contract shall, however not be limited in any way so as to restrict or limit the liabilities or obligations of any of the Parties of this Deed of Undertaking.
5. It is expressly understood and agreed between the Parties to this Undertaking that the responsibilities and obligations of each of the Parties are given as in the bid. It is further undertaken by the parties that the above sharing of responsibilities and obligations shall not in any way be a limitation of joint and several responsibilities of the Parties under the Contract.
6. It is also understood that this Undertaking is provided for the purposes of undertaking joint and several liabilities of the partners to the Joint Venture for submission of the bid and performance of the Contract. and that this Undertaking shall not be deemed to give rise to any additional liabilities or obligations, in any manner or any law, on any of the Parties to this Undertaking or on the Joint Venture, other than the express provisions of the Contract.
7. This Undertaking shall be construed and interpreted in accordance with the provisions of the Contract.
8. In case of an award of a Contract, we the parties to this Deed of Undertaking do hereby agree that we shall be jointly and severally responsible for furnishing a Contract performance security from a bank in favour of the Purchaser in the currency/currencies of the Contract. In case of award on us, the delineation of scope of work shall be as per the following:

Sl. No.	Scope of Work to be executed by	
	Party No.-1	Party No.-2

9. It is further agreed that this Deed of Undertaking shall be irrevocable and shall form an integral part of the bid and shall continue to be enforceable till the Purchaser discharges the same or upon the completion of the Contract in accordance with its provisions, whichever is earlier. It shall be effective from the date first mentioned above for all purposes and intents.

IN WITNESS WHEREOF, the Parties to this Deed of Undertaking have through their authorised representatives executed these presents and affixed Common Seals of their companies, on the day, month and year first mentioned above.

<p>For Lead Partner (Party No.-1) For and on behalf of M/s</p> <p>Common Seal of has been affixed in my/ our presence pursuant to Board of Director's Resolution dated</p> <p>Name Designation</p> <p>Signature (Signature of Authorized representative)</p> <p>WITNESS : I. II.</p>	<p>For Party No.-2 For and on behalf of M/s.....</p> <p>Common Seal of has been affixed in my/ our presence pursuant to Board of Director's Resolution dated</p> <p>Name Designation</p> <p>Signature (Signature of Authorized representative)</p> <p>WITNESS : I. II.</p>
<p>For Party No.-3 For and on behalf of M/s.....</p> <p>Common Seal of has been affixed in my/ our presence pursuant to Board of Director's Resolution dated</p> <p>Name Designation</p> <p>Signature (Signature of Authorized representative)</p> <p>WITNESS : I. II.</p>	

FORM OF POWER OF ATTORNEY FOR JOINT VENTURE (if applicable)
(On Non-Judicial Stamp Paper of Appropriate Value if required)

KNOW ALL MEN BY THESE PRESENTS THAT WE, the Partners whose details are given hereunder..... have formed a Joint Venture under the laws of and having our Registered Office/ Head Office at (hereinafter called the 'Joint Venture' which expression shall unless repugnant to the context or meaning thereof, include its successors, administrators and assigns) acting through M/s..... being the Partner incharge do hereby constitute, nominate and appoint M/s..... a Company incorporated under the laws of and having its Registered/ Head Office at as our duly constituted lawful Attorney (hereinafter called "Attorney" or "Authorised Representative" or "Partner In-charge") to exercise all or any of the powers for and on behalf of the Joint Venture in regard to Specification No.....; Package, the bids for which have been invited by Energy Efficiency Services Limited, a Company incorporated under the Companies Act of 1956 having its registered office at NFL Building, 5th & 6th Floor, Core - III, SCOPE Complex, Lodhi Road, New Delhi - 110003, INDIA (hereinafter called the "Purchaser") to undertake the following acts:

- i) To submit proposal and participate in the aforesaid Bid Specification of the Purchaser on behalf of the "Joint Venture".
- ii) To negotiate with the Purchaser the terms and conditions for award of the Contract pursuant to the aforesaid Bid and to sign the Contract with the Purchaser for and on behalf of the "Joint Venture".
- iii) To do any other act or submit any document related to the above.
- iv) To receive, accept and execute the Contract for and on behalf of the "Joint Venture".
- v) To receive payment on behalf of the "Joint Venture".
- vi) To authorize any other partners of the Joint Venture, if necessary, to receive payments under the contract.

It is clearly understood that the Partner In-charge shall ensure performance of the Contract(s) and if one or more Partner fail to perform their respective portions of the Contract(s), the same shall be deemed to be a default by all the Partners.

It is expressly understood that this Power of Attorney shall remain valid binding and irrevocable till completion of the Warranty Period in terms of the Contract.

The Joint Venture hereby agrees and undertakes to ratify and confirm all the whatsoever the said Attorney / Authorised Representative quotes in the bid, negotiates and signs the Contract with the Purchaser and/or proposes to act on behalf of the Joint Venture by virtue of this Power of Attorney and the same shall bind the Joint Venture as if done by itself.

IN WITNESS THEREOF the Partners Constituting the Joint Venture as aforesaid have executed these presents on this day of under the Common Seal(s) of their Companies.

For and on behalf of the Partners of Joint Venture

.....
.....
.....

The Common Seal of the above Partners of the Joint Venture :

The Common Seal has been affixed there unto in the presence of :

WITNESS

1. Signature.....

Name

Designation

Occupation

2. Signature.....

Name

Designation

Occupation

Notification of Award

[Format for Notification of Award to be issued to successful Consultant on letterhead paper of the Employer]

Ref. No.: Date:

.....(insert Consultant’s Name & Address)

Attn.: Mr.....

Sub.: Notification of Award for (insert name of the Tender)

Specification No.:

(Project Funding: Domestic).

Dear Sir,

1. REFERENCE

This has reference to the following:

1.1. RfP documents for the subject package issued to you vide our letter Ref. No..... Dated.....,

1.1.1. Amendment/Errata No. to RfP Documents issued to you vide our letter no..... dated (Applicable only if any Errata/ Amendment to the RfP Documents has been issued subsequently)

1.1.2. Clarifications to the RfP Documents, pursuant to pre-Bid conference held on, issued to you vide our letters no. dated (Use as applicable) (Applicable only if any clarification to the RfP Documents has been issued subsequently)

(INCLUDE AS FURTHER SUB-PARAGRAPHS ANY OTHER CORRESPONDENCE MADE TO THE CONSULTANT AFTER ISSUANCE OF RfP DOCUMENTS UP TO BID OPENING)

1.2. First envelope of your Bid submitted for the subject package under Bid reference no. dated was opened on..... (Use as applicable)

1.3. Intimation for Opening of Second Envelope issued to you vide our letter no. dated

1.4. Second Envelope of your Bid under Bid/Proposal reference no dated was opened on..... (Use as applicable)

1.5. (to be inserted if applicable) Post bid discussions we had with you on various dates from to resulting into the Minutes of Meeting/ Record Notes of Post Bid Discussions enclosed as APPENDIX (NOA)-1with this Notification of Award.

2. AWARD OF CONTRACT AND ITS SCOPE

2.1. We confirm having accepted your Bid (referred to at para 1.3 & 1.5 above) read in conjunction with all the specifications, terms & conditions of the RfP Documents (referred to at para 1.2, 1.2.1 & 1.2.2 [modify as applicable] above) and specific confirmations recorded in the Record Notes of Post Bid Discussions (referred to at para 1.6 above), and award on you the Contract for (insert name of the Tender)

..... The scope of work inter-alia includes..... (Indicate brief Scope of Work) as detailed in the documents referred hereinabove.

The scope of work under this Notification of Award (NOA) shall also include all such items which are not specifically mentioned in the RfP Documents and/or your Bid but are necessary for the successful completion of your scope under the Contract for (insert name of Tender), unless otherwise specifically excluded in the RfP Documents or in this NOA.

3. CONTRACT PRICE

3.1. The total Contract Price for the entire scope of work under this Contract shall be (Specify the currency and the amount in figures & words) as per the break-up attached as Annexure-X:

3.2. Notwithstanding the break-up of the Contract Price, the Contract shall, at all times, be construed as a single source responsibility Contract and any breach in any part of the Contract shall be treated as a breach of the entire Contract.

4. You are required to furnish at the earliest a Performance Security(ies), as per the RfP Documents, for an amount of (Specify the value) i.e. equal to 10% (Ten percent) of the Contract Price, and valid upto and including and any other securities as per the RfP Documents. (In case any other performance security is required to be furnished, the same is to be mentioned here)

5. All the bank guarantees shall be furnished from an eligible bank as described in the RfP Documents.

6. The schedule for Completion of entire scope of works covered under (insert name of Tender) shall be ... (indicate the completion schedule) months from the date of issue of this Notification of Award for all contractual purposes.

7. This Notification of Award constitutes formation of the Contract and comes into force with effect from the date of issuance of this Notification of Award.

8. You shall enter into a Contract Agreement with us within twenty-eight (28) days from the date of this Notification of Award.

9. This Notification of Award is being issued to you in duplicate. We request you to return its duplicate copy duly signed and stamped on each page including the enclosed Appendix as a token of your acknowledgement.

Please take the necessary action to commence the work and confirm action.

Yours faithfully,
For and on behalf of

.....(Name of the Employer)

(Authorised Signatory)

Enclosures (if Applicable):

APPENDIX (NOA) - 1 - Record Notes of Post - Bid Discussions held on various dates from to
.....

Contract Agreement

[Format for Contract Agreement to be signed between successful Bidder and Employer on INR 100/- non-judicial Stamp Paper]

CONTRACT AGREEMENT BETWEEN..... (Name of Employer) AND M/s..... (Name of Bidder)

THIS CONTRACT AGREEMENT No.....(also referred to as 'Contract') is made on the day of 20....

BETWEEN

(1)(Name of Employer) a company incorporated under the laws of Companies Act 1956 and having its Registered Office at (registered address of the Employer) and its Corporate Office at(address of the Employer)..... (hereinafter called "the Employer" and also referred to as "... (insert abbreviated name of the Employer) ")

and

(2) M/s(Name of Bidder), a company incorporated under the laws of Companies Act 1956 and having its Principal place of business at (Address of Bidder) and Registered Office at(Registered address of Bidder) (hereinafter called "the Agency" and also referred to as "... (insert abbreviated name of the Bidder) ").

WHEREAS the Employer desires to engage the bidder for (Indicate brief scope of work) for the complete execution of the (insert name of Package along with name of the Project) as detailed in the Contract Document, and the bidder has agreed to such engagement upon and subject to the terms and conditions hereinafter appearing.

NOW IT IS HEREBY AGREED as follows:

Article 1. Contract Documents

1.1. Contract Documents

The following documents shall constitute the Contract between the Employer and the bidder, and each shall be read and construed as an integral part of the Contract:

VOLUME - A

1. This Contract Agreement and the Appendices thereto.
2. Notification of Award Ref. No. dated

VOLUME - B

3. Complete "RfP Documents" read in conjunction with Amendments to to the RfP Documents.

VOLUME - C

4. Proposal Submitted by the Consultant. (Only relevant extracts are attached herewith for easy reference. Should the circumstances warrant, the original Proposal along with the enclosures thereof, shall be referred to.).

1.2. Order of Precedence

In the event of any ambiguity or conflict between the Contract Documents listed above, the order of precedence shall be the order in which the Contract Documents are listed in Article 1.1 (Contract Documents) above.

1.3. Definitions (Reference Conditions of Contract Clause 1.0.1)

1.3.1. Capitalized words and phrases used herein shall have the same meanings as are ascribed to them in the Conditions of Contract.

Article 2. Contract Price and Terms of Payment

2.1. Contract Price

The Employer hereby agrees to pay to the bidder the Contract Price in consideration of the performance by the bidder of its obligations hereunder. The Contract Price shall be the aggregate of (amount in words) (.....(amount in figures)), or such other sums as may be determined in accordance with the terms and conditions of the Contract. The break-up of the Contract price is as per attached Annexure-X. The detailed break-up of Contract Price is given in the relevant Appendices hereto.

2.2. Terms of Payment (Reference Conditions of Contract Clause 13.0.0)

The terms and procedures of payment according to which the Employer will reimburse the bidder are given in Appendix 1 (Terms and Procedures of Payment) hereto.

Article 3. Effective Date for Determining Time for Completion

3.1. Effective Date (Reference Conditions of Contract Clause 1.0.1)

The Time of Completion of entire scope of work shall be determined from the date of the Notification of Award i.e., from

Article 4. Appendices

The Appendices listed in the List of Appendices, as mentioned below, shall be deemed to form an integral part of this Contract Agreement.

Reference in the Contract to any Appendix shall mean the Appendices attached hereto, and the Contract shall be read and construed accordingly.

List of Appendices

- Appendix 1 Terms and Procedures of Payment
- Appendix 2 Price Adjustment
- Appendix 3 Insurance Requirement
- Appendix 4 Time Schedule
- Appendix 5 List of Approved Subcontractors
- Appendix 6 Scope of Works and Supply by the Employer
- Appendix 7 List of Documents for Approval or Review
- Appendix 8 Guarantees, Liquidated Damages for Non - Performance
- Appendix 9 Contract Co-ordination Procedure
- Appendix 10 Summary of Contract Price for Services for complete scope of the work as per RfP Documents

IN WITNESS WHEREOF the Employer and the Consultant have caused this Agreement to be duly executed by their duly authorized representatives the day and year first above written.

<p>Signed by for and on behalf of the Employer</p> <p>.....</p> <p>Signature</p> <p>.....</p> <p>Title</p> <p>in the presence of</p>	<p>Signed by for and on behalf of the Consultant</p> <p>.....</p> <p>Signature</p> <p>.....</p> <p>Title</p> <p>in the presence of</p>
--	--

TERMS AND PROCEDURES OF PAYMENT

In accordance with the provisions of GCC Clause 12 (Terms of Payment), the Employer shall pay the Contractor in the following manner and at the following times, on the basis of the Price Breakdown given in the section on price schedules. Payments will be made in the currencies quoted by the Bidder unless otherwise agreed between the parties. The Contractor may make applications for payment in respect of part deliveries as work proceeds.

1. TERMS OF PAYMENT:

In addition to the Conditions stipulated under GCC Clause 12, the following terms & Conditions will apply:

1.1 Payment Terms:

Bidder shall submit the quarterly invoices in arrear mode and payment may be released within 30 days after submission of invoices & relevant documents/certificates by service provider and certification of engineer in charge of EESL.

Further, the payment shall be paid only on fulfilment of following conditions:

- a) Acknowledgement of NOA/LOA and signing of contract agreement.
- b) Submission of GST compliant Invoice
- c) Submission of CONTRACT PERFORMANCE GUARANTEE (CPG)
- d) Certification by Project manager/ Engineer in Charge

1.2 Payment towards Taxes and Duties:

Employer is liable for and shall pay only applicable GST on various components of prices. Implementing Partners are required to quote their prices inclusive of all taxes and duties except applicable GST. The Input Tax Credit (ITC) available, if any, under the GST Law as per the relevant Government policies wherever applicable shall be taken into account by the Implementing Partner while quoting bid price. EESL's liability shall be only for applicable GST.

No increase in Taxes and Duties (in case of change), which are payable as per the Contract, shall be allowed beyond the original delivery/ services/ Installation dates unless specifically stated in the Time Extension Letter, if any, issued by the Employer. The Employer will, however, be entitled to any decrease in the Contract Price which may be caused due to lower payable Taxes and Duties amount in case of delivery of Goods/ Installation beyond the original delivery/Installation dates. Therefore, in case of delivery of Goods/Installation beyond the original delivery/ Installation dates, the liability of the Employer shall be limited to the lower of the payable Taxes and Duties amount which may work out either on schedule date or actual date of despatch of Goods/Installation.

Notwithstanding anything above or elsewhere in the contract, in event that input Tax credit of the GST charged by the supplier, is denied by the tax authorities to the employer for reasons associated with non-compliance/incorrect compliance by the supplier, the employer shall be entitled to recover such amount from the supplier by way of adjustment from any of the subsequent invoices submitted by the supplier to the employer. In addition to the amount of GST, the employer shall be entitled to recover interest and penalty, in case any interest/or penalty is imposed by the tax authorities on the employer for incorrect/wrong availment of input tax credit. The employer must determine whether the denial of credit is linked to non-compliance /in direct compliance of the supplier and the said determination shall be binding on the supplier.

End of Appendix-1

Appendix-2 to Contract Agreement

PRICE ADJUSTMENT

The Contract price shall remain **FIRM** and **FIXED** and shall not be subject to Price adjustment for the entire duration of the Contract, in accordance with the provisions of the RfP documents.

End of Appendix-2

INSURANCE REQUIREMENTS (if required)

A) Insurances to be taken out by the Contractor

In accordance with the provisions of GCC Clause 34, the Contractor shall at its expense take out and maintain in effect, or cause to be taken out and maintained in effect, during the performance of the Contract, the insurances set forth below in the sums and with the deductibles and other conditions specified. The identity of the insurers and the form of the policies shall be subject to the approval of the Employer, such approval not to be unreasonably withheld. The inability of the insurers to provide insurance cover in the sums and with the deductibles and other conditions as set forth below, shall not absolve the Contractor of his risks and liabilities under the provisions of GCC Clause 34. However, in such a case the Contractor shall be required to furnish to the Employer documentary evidence from the insurer in support of the insurer's inability as aforesaid.

(a) Transit Insurance Policy

(I)(i) Transit Insurance Policy for indigenous equipment

Transit Insurance Policy shall be taken wherein only inland transit is involved for the movement of Plant and Equipment including mandatory Spares supplied from within India. The policy shall cover movement of Plant and Equipment including mandatory Spares from the manufacturer's works to the final destination site. Inland Transit Clause (ITC) 'A' along with Strike Riots & Civil Commotion (SRCC) extension cover shall be taken.

Amount	Deductible Limits	Parties insured	From	To
100% of Supply Component of Contract Price of all the Plant and Equipment including mandatory Spares (if any) to be supplied from within India plus GST, if additionally payable.	Nil	Contractor & Employer	Manufacturer ware-house	Project's ware-house store at final destination or Site location

Note: Deductibles, if any, shall be to the Contractor's account

(II) If during the execution of Contract, the Employer requests the Contractor to take any other add-on cover(s)/ supplementary cover(s) in aforesaid insurance, in such a case, the Contractor shall promptly take such add-on cover(s)/ supplementary cover(s) and the charges towards such premium for such add-on cover(s)/ supplementary cover(s) shall be reimbursed to the Contractor on submission of documentary evidence of payment to the Insurance company. Therefore, charges towards premium for such add-on cover(s)/ supplementary cover(s) are not included in the Contract Price.

(III) The Contractor shall take the policy in the joint names of Employer and the Contractor. The policy shall indicate the Employer as the beneficiary. However, if the Contractor is having an open policy for its line of business, it should obtain an endorsement of the open cover policy from the insurance company indicating that the dispatches against this Contract are duly covered under its open policy and include the name of the Employer as jointly Insured in the endorsements to the open policy.

(b) Erection/Installation All Risk Policy/Contractor All Risk Policy:

(I) The policy should cover all physical loss or damage to the facility at site during storage, erection and commissioning covering all the perils as provided in the policy as a basic cover and the add on covers as mentioned at Sl. No. (III) below.

Amount	Deductible limits	Parties insured	From	To
100% of Supply Component of Contract Price of all the Plant and Equipment including mandatory Spares to be supplied from within India plus GST, if additionally, payable. and 100% of installation/erection price component	Nil	Contractor & Employer	Receipt at site of first lot of the Plant and Equipment including mandatory Spares	Up to Operational Acceptance

Note: Deductibles, if any, shall be to the Contractor's account

(II) The Contractor shall take the policy in the joint name of Employer and the Contractor. All these policies shall indicate Employer as the beneficiary. The policy shall be kept valid till the date of the Operational Acceptance of the project and the period of the coverage shall be determined with the approval of the Employer.

If the work is completed earlier than the period of policy considered, the Contractor shall obtain the refund as per provisions of the policy and pass on the benefit to Employer. In case no refund is payable by the insurance company then the certificate to that effect shall be submitted to Employer at the completion of the project.

(III) The following add-on covers shall also be taken by the Contractor:

- i) Earthquake
- ii) Terrorism
- iii) Escalation cost (approximately @10% of sum insured on annual basis)
- iv) Extended Maintenance cover for Defect Liability Period
- v) Design Defect

- vi) Other add-on covers viz., 50-50 clause, 72 hours' clause, loss minimization clause, waiver of subrogation clause (for projects of more than Rs.100 crores, cover for offsite storage/fabrication (over Rs.100crores).

- (IV) *Third Party Liability cover with cross Liability within Geographical limits of India as on ADD-on cover to the basic EAR cover:*

The third party liability add-on cover shall cover bodily injury or death suffered by third parties (including the Employer's personnel) and loss of or damage to property (including the Employer's property and any parts of the Facilities which have been accepted by the Employer) occurring in connection with supply and installation of the Facilities.

Amount	Deductible limits	Parties insured	From	To
The third party liability limit shall be 10% of the project value for single occurrence/ multiple occurrences in aggregate during the entire policy period.	Nil	Contractor/ Sub-contractor	Receipt at site	Upto Defect Liability Period.

Note: Deductibles, if any, shall be to the Contractor's account

- (c) **Automobile Liability Insurance**
The Contractor shall ensure that all the vehicles deployed by the Contractor or its Subcontractors (whether or not owned by them) in connection with the supply and installation of the Facilities in the project are duly insured as per RTA act. Further the Contractor or its Subcontractors may also take comprehensive policy (own damage plus third party liability) of each individual vehicles deployed in the project on their own discretion in their own name to protect their own interest.

- (d) **Workmen Compensation Policy:**

- (I) Workmen Compensation Policy shall be taken by the Contractor in accordance with the statutory requirement applicable in India. The Contractor shall ensure that all the workmen employed by the Contractor or its Subcontractors for the project are adequately covered under the policy.
- (II) The policy may either be project specific covering all men of the Contractor and its Subcontractors. The policy shall be kept valid till the date of Operational Acceptance of the project.

Alternatively, if the Contractor has an existing 'Workmen Compensation Policy' for all its employees including that of the Subcontractor(s), the Contractor must include the interest of the Employer for this specific Project in its existing 'Workmen Compensation Policy'.

(III) Without relieving the Contractor of its obligations and responsibilities under this Contract, before commencing work the Contractor shall insure against liability for death of or injury to persons employed by the Contractor including liability by statute and at common law. The insurance cover shall be maintained until all work including remedial work is completed including the Defect Liability Period. The insurance shall be extended to indemnify the Principal for the Principal's statutory liability to persons employed by the Contractor.

The Contractor shall also ensure that each of its Subcontractors shall effect and maintain insurance on the same basis as the 'Workmen Compensation Policy' effected by the Contractor.

(e) Contractor's Plant and Machinery (CPM) Insurance

The Employer (including without limitation any consultant, servant, agent or employee of the Employer) shall not in any circumstances be liable to the Contractor for any loss of or damage to any of the Contractor's Equipment or for any losses, liabilities, costs, claims, actions or demands which the Contractor may incur or which may be made against it as a result of or in connection with any such loss or damage.

The Employer shall be named as co-insured under all insurance policies taken out by the Contractor pursuant to GCC Clause 34.1, except for the Third Party Liability, Workmen Compensation Policy Insurances, and the Contractor's Subcontractors shall be named as co-insureds under all insurance policies taken out by the Contractor pursuant to GCC Sub-Clause 34.1 except for the Cargo Insurance During Transport, Workmen Compensation Policy Insurances. All insurer's rights of subrogation against such co-insureds for losses or claims arising out of the performance of the Contract shall be waived under such policies.

B) Insurances to be taken out by the Employer

The Employer shall at its expense take out and maintain in effect during the performance of the Contract the following insurances.

Amount	Deductible limits	Parties Insured	From	To
-NIL-				

-- End --
End of Appendix-3

TIME SCHEDULE

1. The Project Completion Schedule shall be as follows:
The refurbishment work has to be completed within One (1) month from the date of issuance of LoA. The Repair and Maintenance along with comprehensive on-site warranty of CCMS will start from the completion of refurbishment period (i.e., 1 month) and continue until the project completion of the respective ULB.

2. The activity(ies) under the Contractor’s programme for Project Completion shall be in the form of a master network (MNW) and shall identify the various activities like Design, engineering, manufacturing, supply, installation, factory testing, transportation to site, site testing and commissioning, etc. of the Facilities or specific part thereof (where specific parts are specified in SCC). The network shall conform to the above Project Completion Schedule.
The successful Bidder shall be required to prepare detailed Network(s) and project implementation plans & programmes and finalize the same with the Employer as per the requirement specified in Technical Specifications, which shall form a part of the Contract.

3. The Employer reserves the right to request minor changes in the work schedule at the time of Award of Contract to the successful Bidder.

4. Time for Completion is the essence of Contract.

End of Appendix-4

LIST OF APPROVED SUBCONTRACTORS (if applicable)

The following Subcontractors/Sub-Implementing Partners are approved for carrying out the item of the facilities indicated. Where more than one Subcontractor is listed, the Contractor is free to choose between them, but it must notify the Employer of its choice in good time prior to appointing any selected Subcontractor. In accordance with GCC Sub- Clause 19, the Contractor is free to submit proposals for Subcontractors for additional items from time to time. No Subcontracts shall be placed with any such Subcontractors for additional items until the Subcontractors have been approved in writing by the Employer and their names have been added to this list of Approved Subcontractors.

Item of Facilities	Approved Subcontractors	Nationality

Further, erection portion of the contract shall not be subcontracted without the prior approval of the Employer. However, such approval shall not be necessary for engaging labour.

End of Appendix-5

SCOPE OF WORKS AND SUPPLY BY THE EMPLOYER

The following personnel, facilities, works and supplies will be provided/supplied by the Employer. Unless otherwise indicated, all personnel, facilities, works and supplies will be provided free of charge to the Contractor.

Personnel Charge to Contractor - None

-----NIL-----

Facilities Charge to Contractor - None

-----NIL-----

Electricity and Water Charge to Contractor - None

-----NIL-----

Works Charge to Contractor - None

-----NIL-----

Supplies Charge to Contractor - None

-----NIL-----

End of Appendix-6

LIST OF DOCUMENTS FOR APPROVAL OR REVIEW

Pursuant to GCC Sub-Clause 20.3, the Contractor shall prepare, or cause its Subcontractor to prepare, and present to the Project Manager the following documents for:

A. Approval

1.

2.

3.

B. Review

1.

2.

3.

Note:

Bidder shall furnish the exhaustive list, which shall be discussed and finalized for incorporation into the Contract Agreement.

End of Appendix-7

GUARANTEES, LIQUIDATED DAMAGES FOR NON - PERFORMANCE

As applicable as per Technical Specs

CONTRACT CO-ORDINATION PROCEDURE

Not Applicable

Important Instruction for participation in the e-Bidding:

Interested bidders have to register themselves on the portal www.tenderwizard.com/EESL through M/s. **Antares Systems Limited** (Application Service Provider (ASP) appointed by EESL) to participate in the bidding under this invitation for bids. It shall be the sole responsibility of the interested bidders to get themselves registered at the aforesaid portal for which they are required to contact M/s. Antares Systems Limited at following contact details to complete the registration formalities:

Bidders are requested to visit "e-Tendering" section at EESL website, www.eeslindia.org for instructions and registration on E-tendering portal.

Steps for Registration on EESL's E-Procurement Portal

- i Open portal by entering URL www.tenderwizard.com/EESL.
- ii Download and read Registration Manual from EESL's e-tendering portal www.tenderwizard.com/EESL
- iii Click on 'REGISTER' link for new registration.
- iv Fill all mandatory fields and click on 'CREATE PROFILE' button.
- v On the next page, upload registration related documents and proceed further.
- vi User ID and system-generated password will be displayed. Login and mandatorily change the system-generated password.
- vii Login with your new password and Register your class-III Signing and Encryption Digital Signature Certificate (DSC).
- viii Also read the instructions given under Registration Manual available at homepage of EESL website www.tenderwizard.com/EESL.

Note: Online registration shall be done on e-tendering website, i.e., www.tenderwizard.com/EESL & in general, activation of registration may take 24 hours. It is sole responsibility of the bidder to register in advance.

There is no fee for Registration on EESL E-procurement Portal.

A. Digital Signature Certificate:

It is mandatory for all the bidders to have class-III Digital Signature Certificate (DSC) with signing and Encryption certificate (in the name of person who will sign the BID) from any of the licensed Certifying Agency (Bidders can see the list of licensed CAs from the link www.cca.gov.in) to participate in e-tendering of EESL.

B. EESL Global Support Telephones and e-mail id

Contact Details: +91-80-45811365, +91-80-45982100, +91-9560095958
mohitkumar@etenderwizard.com, krishna.a@etenderwizard.com

NIT/Bid Document No.: EESL/06/24-25/SERC-Contracts/TS/CCMS - GHMC & ULB/OTE-232414, Date: 25/09/2024	SECTION -6 (Forms)	Page 65 of 74
--	-----------------------	---------------

For proper uploading of the bids on the portal namely www.tenderwizard.com/EESL (*hereinafter referred to as the 'portal'*), it shall be the sole responsibility of the bidders to apprise themselves adequately regarding all the relevant procedures and provisions as detailed at the portal as well as by contacting from **M/s. Antares Systems Limited** directly, as and when required, for which contact details are mentioned above. The Employer in no case shall be responsible for any issues related to timely or properly uploading/submission of the bid in accordance with the relevant provisions of SectionII - ITB of the Bidding Documents.

Tender Conditions applicable for MSE and Start-ups

In case MSE bidders are exempted from submission of Bidding Document fee & Bid Security as per Clause No 1.4 & 2.4 of ITB Section-2, respectively, then bidder has to submit copy of valid 'Udyam Registration Certificate' in Envelop-1 for the purpose of Evaluation. **Micro and Small Enterprises (MSEs) registered with Udyam Registration Portal as specified by Ministry of Micro, Small and Medium Enterprises are exempted from submission of fee towards the cost of Bidding Documents and Bid Security/EMD as per the Provisions of the Public Procurement Policy for Micro and Small Enterprises (MSEs) order 2012, Notification dated 01/06/2020 and 26/06/2020 read in conjunction with related notifications issued from time to time for such enterprises. Such registration should be prior to deadline for submission of Bids.**

1. For claiming the above exemption for Start-ups, a valid certificate of Start-up-recognized by 'Department of Industrial Policy & Promotion (DIPP)' along with Business eligibility certificate or any other document issued by Govt/Recognized institute is required in support of product/ service item being tendered.
2. **Purchase Preference to MSEs:** Subject to meeting terms and conditions stated in the tender document including but not limiting to prequalification criteria, 25% of the total quantity of the tender is earmarked for MSEs registered with above mentioned agencies/bodies for the tendered item. Out of the 25% target of annual procurement from micro and small enterprises 4% & 3% shall be earmarked for procurement from micro and small enterprises owned by Scheduled Caste (SC) & Scheduled Tribe (ST) entrepreneurs & Women entrepreneurs respectively. In the event of failure of such MSEs to participate in the tender process or meet the tender requirements and L1 price 4% & 3% sub targets so earmarked shall be met from other MSEs.

Type of tender	Price quoted by MSE	How the tender shall be finalized
Can be split	L1	Full Order on MSE subject to tender evaluation condition
Can be split	Not L1 but within L1+15%	25% order on MSE subject to matching L1 price
Cannot be split	L1	Full Order on MSE
Cannot be split	Not L1 but within L1+15%	Full Order on MSE subject to matching L1 price

- 2.1 **Where the tendered quantity can be split:** In a bid, if prices quoted by participating Micro and Small Enterprises (MSEs) fall within the price band of L1+15%, such MSE shall also be allowed to supply 25% of the total tendered quantity by bringing down their prices to L1 prices. In case of more than one such MSE (L1+15%) the supply shall be shared proportionately (to tendered quantity), subject to the condition that such MSEs match the L1 price. Further, 4% out of above 25% shall be from MSEs owned by SC/ST entrepreneurs & 3% out of above shall be from MSEs owned by women entrepreneurs. This quota is to be transferred to the general category MSEs in case of NON-availability of MSEs owned by SC/ST entrepreneurs & Women entrepreneurs respectively.

2.2 **Where the tendered quantity cannot be split/divide:** In case of tender item is non-split able or non-dividable, etc.: MSE quoting price within price band L1+15% may be awarded for full/complete supply of total tendered value to MSE, considering spirit of Public Procurement Policy, 2012 for enhancing the Govt. Procurement from MSE.

2.3 MSE owned by SC/ST is defined as:

- a. In case of proprietary MSE, proprietor(s) shall be SC /ST
- b. In case of partnership MSE, The SC/ST partners shall be holding at least 51% shares in the enterprise.
- c. In case of Private Limited Companies, at least 51% share shall be held by SC/ST promoters.

2.4 MSE owned by Women is defined as:

- a. In case of proprietary MSE, proprietor(s) shall be Women
- b. In case of partnership MSE, The Women partners shall be holding at least 51% shares in the enterprise.
- c. In case of Private Limited Companies, at least 51% share shall be held by Women promoters.

If bidder does not provide appropriate document or any evidence to substantiate the above, then it will be presumed that he does not qualify for any preference admissible under the Public Procurement Policy, 2012.

3. For relaxing the PQ/QR conditions regarding prior turnover and prior experience for MSEs and start-ups, the prior turnover and prior experience will be as under subject to their meeting of quality and technical specifications: -

Category of tender	Past experience	Average Turn Over	Award Philosophy
Can be split as per tender conditions	25% of total experience as required for general bidders	25% of total ATO as required for general bidders	<p>(a) If MSE is L1, order will be given as per split criteria in order of ranking as defined in the tender document which could be greater than 25%. The treatment for award will be same for MSE as general bidder.</p> <p>(b) If MSE is other than L1 bidder, then the split criteria as per tender condition will be followed subject to price matching with L1 bidder in order of ranking treating the MSE bidder(s) at par with the general bidder. In such event also, order(s) going to MSE bidder(s) could be greater than 25%. If order(s) going to MSE bidder(s) is/are less than 25% after the matching of rates with L1 bidder by adopting the tender split criteria, then the clause of purchase preference for award to MSE bidder(s) up to 25% of the tendered quantity subject to matching L1 rates will be followed to make the total quantity going to MSE bidder(s) @25%; provided the rates are within L1+15% range. In such cases, remaining quantity after award of 25% to MSE bidder(s) shall be distributed amongst other eligible bidders in the pre-declared split ratio. If order(s) going to MSE bidder(s) is less than 25% and also MSE bidder(s) not meeting the condition of purchase preference clause i.e. quoted rates not within L1+15% range, then the order(s) quantity going to MSE bidder(s) in such cases shall be less than 25% which will be in line with the tender conditions.</p> <p>(c) If MSE is in the range of L1+15% and not getting the order after splitting and award is going to all non MSE bidder(s), then in such event 25% will be awarded to MSE bidder(s) who fall in the range of L1+15% subject to price matching and remaining 75% will be awarded as per the tender conditions to general bidders subject to matching L1 rates.</p> <p>(d) If after splitting MSE bidder(s) are getting order for more than or equal to 25%, then other MSE bidder(s) will not be awarded any work under purchase preference clause even if they fall in the range of L1+15%. However, they will be considered for award of work as any other general bidder as per tender conditions subject to matching of rates in order of ranking.</p> <p>(e) If MSE bidder is a single resultant vendor, then the</p>

			<p>quantity that would be considered for award to such bidder will be as defined in the pre- declared split ratio to L-1 bidder in the tender condition; provided the quoted rates of the bidder are found reasonable by EESL. However, EESL reserves the right to award 100% quantity to such MSE bidder provided the MSE bidder has got ATO which is corresponding to the cumulative applicability for 100% order value.</p> <p>In case, where ATO of the MSE bidder is less than what is required for 100% cumulative order value, then work may be proportions to the ATO requirement of 100% order value , then maximum 56% work may be awarded to the MSE bidder. However , in such case EESL reserves the right to award appropriate quantity based on the existing requirement and EESL which will be binding on the bidder. EESL may take consent from the bidder for award of such quantity (which is over and above the quantity to be allotted to L1 bidder as per pre-declared split ratio) before award.</p>
Cannot be split as per tender conditions	25% of total experience as required for general bidders	85% of total ATO as required for general bidders	<p>(a) If MSE is L1, 100% order will be given to MSE.</p> <p>(b) If MSE is within the range of L1 + 15%, 100% order will be given to MSE subject to price matching with L1 bidder.</p> <p>(c) If MSE is not L1 and not in range of L1 + 15%, no work will be given to MSE.</p>

4. Start-ups are also covered under 25% purchase preference from procurement basket of MSEs as defined in point (3) above, provided that participating Start-ups submit all the relevant documents pertaining to MSEs as defined in point (1) above and documents for start-ups as defined in point (2) above.

whereas, startup means an entity, incorporated or registered in India:

- i. Not prior to seven years, however for Biotechnology Startups not prior to ten years,
- ii. With annual turnover not exceeding INR 25 crore in any preceding financial year, and
- iii. Working towards innovation, development or improvement of products or processes or services, or if it is a scalable business model with a high potential of employment generation or wealth creation.
- iv. Provided that such entity is not formed by splitting up, or reconstruction, of a business already in existence. Provided also that an entity shall cease to be a Startup if its turnover for the previous financial years has exceeded INR 25 crore or it has completed 7 years and for biotechnology startups 10 years from the date of incorporation/ registration.

Note: For Start-up firms, Gazette Notifications dated: 17-Feb-2016, G.S.R. 180 (E), and subsequently issued notifications will be considered.

NOTES: -

- a. In case where tender quantity can be split and MSE bidder is already getting order more than 25% of the tender value, no additional purchase preference is required to be given in that tender.
- b. In case MSE bidder is already getting order for less than 25% of the tender quantity, purchase preference to this and other MSE vendor (together) shall be given only up to the differential quantity to make total as 25% to MSE vendor subject to L1+15% and price matching.
- c. Public Procurement policy is meant for procurement of goods produced and services rendered by Micro and Small Enterprises. The preference to MSEs is not applicable for works contracts where supply of goods not produced by MSEs is also involved.
- d. The eligibility of MSE bidders for any other benefits/relaxations for MSE bidders indicated in Tender documents shall be as indicated in the above "Tender conditions for Benefits/Preference for Micro & Small Enterprises(MSEs)."
- e. If bidder submits Bid Document Fee and also MSE certificate along with the offer, then the bidder will be treated as general bidder and no relaxation will be given to such bidders pertaining to MSE's.
- f. The registration certificate must be valid as on bid closing date of the tender. Bidder shall ensure validity of certificate in case bid closing date is extended. The MSEs who have applied for registration or renewal of registration with any of the above agencies/bodies, but have not obtained the valid certificate till the end date of bid submission, are not eligible for any exemption/preference and will not be considered. Such offers will be treated as offers received without EMD and are rightly rejected.
- g. Traders, resellers, distributors and agents will not be considered for availing benefits under PP Policy 2012 for MSEs.

(Price-Bid)*(For illustration purpose Only, please fill it online only)***Package-1 (For Greater Hyderabad Municipal Corporation):**

Refurbishment and Repair & Maintenance of CCMS along with comprehensive on-site warranty (including supply of spares parts) for a period of 1 year or until the project completion of (i.e., Apr'2025) in GHMC Street lighting project in the state of Telangana.

S. No.	Description of work	Proposed Quantity	Unit of Measurement (UOM)	No. of Quarters (in No's)	Base price per unit exclusive of GST on F.OR. destination basis (In Rs.)	Total exclusive of GST on F.OR. destination basis (In Rs.)
1		2	3	4	5	6=2*4*5
A	Refurbishment and Repair & Maintenance of CCMS along with comprehensive on-site warranty (including supply of spares parts) for a period of 1 year or until the project completion (i.e., Apr'2025) in GHMC Street lighting project in the state of Telangana	7,604	Per Quarter	4		
	Total (A)					

Note:

- No separate installation cost and IDC Cost will be provided if existing CCMS are replaced with new CCMS.
- In price bid table, unit rate has to be quoted per quarter. The maintenance period will be co-terminus with project completion of respective ULB.
- The quoted rate is to include costs towards full scope of work, etc. of the contractor as per this RfP.
- Quoted rate shall be exclusive of all taxes & duties. The applicable taxes & duties, however, shall be specified by the bidder in writing (text) elsewhere in their techno-commercial bid.
- The bidder is required to be registered with relevant tax authorities for the relevant services in order to claim taxes.
- If there is any discrepancy in rate quoted in words and figures, then rates quoted in words shall be considered.
- The bill of quantity may vary with +/- 20% deviation.
- Competitive rates are to be quoted and price will remain firm for entire Contract Period.

Package-2 (For ULB across Telangana):

Refurbishment and Repair & Maintenance of CCMS along with comprehensive on-site warranty (including supply of spares parts) for a period until the project completion of respective ULB (approx. 4 years) in Street lighting project in the state of Telangana.

S. No.	Description of work	Proposed Quantity	Unit of Measurement (UOM)	No. of Quarters (in Nos)	Base price per unit exclusive of GST on F.O.R. destination basis (In Rs.)	Total exclusive of GST on F.O.R. destination basis (In Rs.)
1		2	3	4	5	6=2*4*5
A	Refurbishment and Repair & Maintenance of CCMS along with comprehensive on-site warranty (including supply of spares parts) for a period until the project completion of respective ULB (approx. 4 years) in Street lighting project in the state of Telangana	4,629	Per Quarter	16		
Total (A)						

Note:

- No separate installation cost and IDC Cost will be provided if existing CCMS are replaced with new CCMS.
- In price bid table, unit rate has to be quoted per quarter. The maintenance period will be co-terminus with project completion of respective ULB.
- The quoted rate is to include costs towards full scope of work, etc. of the contractor as per this RfP.
- Quoted rate shall be exclusive of all taxes & duties. The applicable taxes & duties, however, shall be specified by the bidder in writing (text) elsewhere in their techno-commercial bid.
- The bidder is required to be registered with relevant tax authorities for the relevant services in order to claim taxes.
- If there is any discrepancy in rate quoted in words and figures, then rates quoted in words shall be considered.
- The bill of quantity may vary with +/- 20% deviation.
- Competitive rates are to be quoted and price will remain firm for entire Contract Period.

Note: Bidder has to mandatorily quote for all the line items. Tender will be evaluated for Total price exclusive of GST. Techno-commercially suitable bidder having the lowest price i.e. lowest price of Grand Total (G) in Price Bid table shall be L-1 bidder. Price bid should be un-conditional, failing which the bid shall be summarily rejected. Price will remain firm till the execution of the contract.

Other terms and conditions: -

NIT/Bid Document No.: EESL/06/24-25/SERC-Contracts/TS/CCMS - GHMC & ULB/OTE-232414, Date: 25/09/2024	SECTION -6 (Forms)	Page 73 of 74
--	--------------------	---------------

1. The Bidder shall indicate in the Price Bid, the unit prices in ₹ (INR) and total Bid prices of the Goods & Services in the prescribed format only. Bidders shall quote for the complete requirement of Goods and Services specified under the Contract on a single responsibility basis, failing which such Bids will not be taken into account for evaluation and will not be considered for award.
2. Participating bidders taking cognizance of the scope of work shall quote the prices accordingly.
3. If there is a discrepancy between words and figures, the amount written in words will prevail.
4. The bidder shall submit PAN and GST Registration Certificate in support of claim of GST.

I/We have read all the terms and conditions of the RfP/IFB/NIT and the Annexure(s) thereto and agree to accept and abide by the same in total. The above quotation has been prepared after taking into account all the terms and conditions of the RfP/IFB/NIT.

Dated:

Fax no.:

(SEAL)

Signature of Tenderer or Their Authorized Representative:

Name & Address of Tenderer:

Phone No:

****END****